

2650CX Hybrid Shovel



Safety



Reliability



Productivity



With the reliability you need and the flexibility you want, the P&H2650CX Hybrid Shovel offers you technologies with decades of experience, designed into an innovative loading tool to help you maintain productivity with a TCO advantage.



Operational ranges

Max reach at ground level	14.64 m	48.02 ft
Max dig reach	17.84 m	58.53 ft
Operator eye level	8.9 m	29.1 ft
Max dump height	11.54 m	37.86 ft
Height of cut	18.11 m	59.42 ft

Machine overview

Operating weight	817,889 kg	1,803,134 lb
Standard track pads	1626 mm	64 in
Ground bearing pressure	29.6 N/cm ²	43 PSI
Engine output	2,386 kW	3,200 HP
Bucket capacity @ 1.9 t/m ³	31.1 m ³	40.7 yd ³
Rated suspended load	127.5 mt	140.5 st

Diesel engines

MTU Detroit diesel engines

Model	2 x 12V4000 series
Type	4-cycle turbocharged
Rated power SAE J1995	2,386 kW (3,200 HP) @ 1,800 rpm
Number of cylinders	12
Bore	170 mm (6.69 in)
Stroke	210 mm (8.27 in)
Displacement	57.2 liter (3491 in ³)

Cummins diesel engines

Model	2 x QSK50
Type	4-cycle turbocharged
Rated power SAW J1995	2,386 kW (3200 HP) @ 1800 rpm
Number of cylinders	16
Bore	159 mm (6.26 in)
Stroke	159 mm (6.26 in)
Displacement	50.3 liter (3069 in ³)

SR generators Single bearing, force air cooled thru-shaft for driving the hydraulic pump drive transmission

Radiator/Oil cooler modules Main Cooling for engines and Auxiliary Cooling for hydraulics, electrical converters, and hydraulic pump drive transmissions

Exhaust system SCR aftertreatment (Cummins Tier IV only) Residential grade silencer provides up to a 28dB noise reduction

Hydraulic system

Main pumps for clamshell and propel	6 variable-displacement, axial-piston pumps
Maximum oil flow	6 x 468 L/min
Maximum pressure clamshell	320 bar / 4,640 PSI
Maximum pressure propel	285 bar / 4,134 PSI
Hydraulic system capacity	3,785 L / 1,000 gal
Hydraulic tank capacity	2,082 L / 550 gal
Bucket cylinders	2
Bore	300 mm
Rod diameter	160 mm
Tilt cylinders	2
Bore	280 mm
Rod diameter	200 mm
High pressure in-line filters	25 micron
Full flow return line filters (10 double elements)	5 x 10 micron

Electronic positive pump control system for tilt, dump and propel functions
Electronic cylinder end stop cushioning system
Electronically controlled hydraulic oil temperature regulation

Electrical system

System voltage	24 V
Batteries in series, parallel	6 x 12V, 6 x 210Ah
Working spot lights	22 x high brightness LED lights
Service lights	16 x LED lights
APU unit (optional)	24VDC system (260A)

Propel system

Hydraulic motors	2 - axial piston variable motors (per side)	
Travel speeds	1st stage - max	0.92 km/hr - 0.57 mph (low)
	2nd stage - max	1.99 km/hr - 1.24 mph (high)
Maximum tractive force	2720 kN / 611,487 lbf	
Crawler shoes per side	37	
Lower rollers per side	7	
Upper rollers per side	3	
Ground bearing pressure	Standard crawler shoe - 1,626 mm/64 in	29.6 N/cm ² 43 PSI
	Crawler shoe - 1,829 mm/72 in	26.6 N/cm ² 38 PSI
	Crawler shoe - 1,981 mm/78 in	24.1 N/cm ² 35 PSI

Each crawler frame is equipped with a high ratio, high torque planetary gearbox. Each gearbox is powered by (2) axial piston hydraulic motors. Gearbox is splash lubricated

Spring-set hydraulic release wet multi plate disc brakes - (1) set per motor

Patent P&H brand Delta drive low tension sprocket drive system with heavy duty cast crawler shoes

Swing system

Swing motors	4 x P&H SR motors @ 200 HP each
Swing drives	4 x stage planetary transmissions
Brakes	Spring loaded / hydraulically released
Max swing speed	3.12 rpm
Slew ring gear	Sealed triple roller swing ring, internal teeth
Switch reluctance (SR) electric motors each coupled with a compact planetary gearbox. Gearbox is oil filled and splash lubricated	

Spring-set hydraulic release wet multi plate disc brakes - (1) set per motor

Main swing bearing is a triple row, sealed cylindrical roller bearing with induction hardened races. Internal ring gear is integral to the swing bearing. Both bearing and ring gear are automatically lubricated

Crowd system

Crowd motors	2 x P&H SR motors @ 400 HP each
Twin low inertia Switch Reluctance (SR) electric motors minimize shock loading	
Direct drive crowd eliminates belt maintenance and improves responsiveness	
Two input pinions shared load for extended life	
Dual spring-set hydraulic release brakes for reliable redundant operation	

Hoist system

Hoist motors	2 x P&H SR motors @ 1,250 HP each
Patent-pending dual planetary system located at the interior of the hoist drum eliminates externally mounted transmissions and optimizes use of deck space	
All gearing and bearings are both pressure fed and splash lubricated with filtered oil, providing reliable operation and eliminating the need for a heat exchanger	
Large 68" diameter drum for extended rope bending life. Ferrule becket system and dual hydraulic duggers are standard for efficient rope change	
Spring-set hydraulic release wet multi plate disc brakes - (1) set per motor	

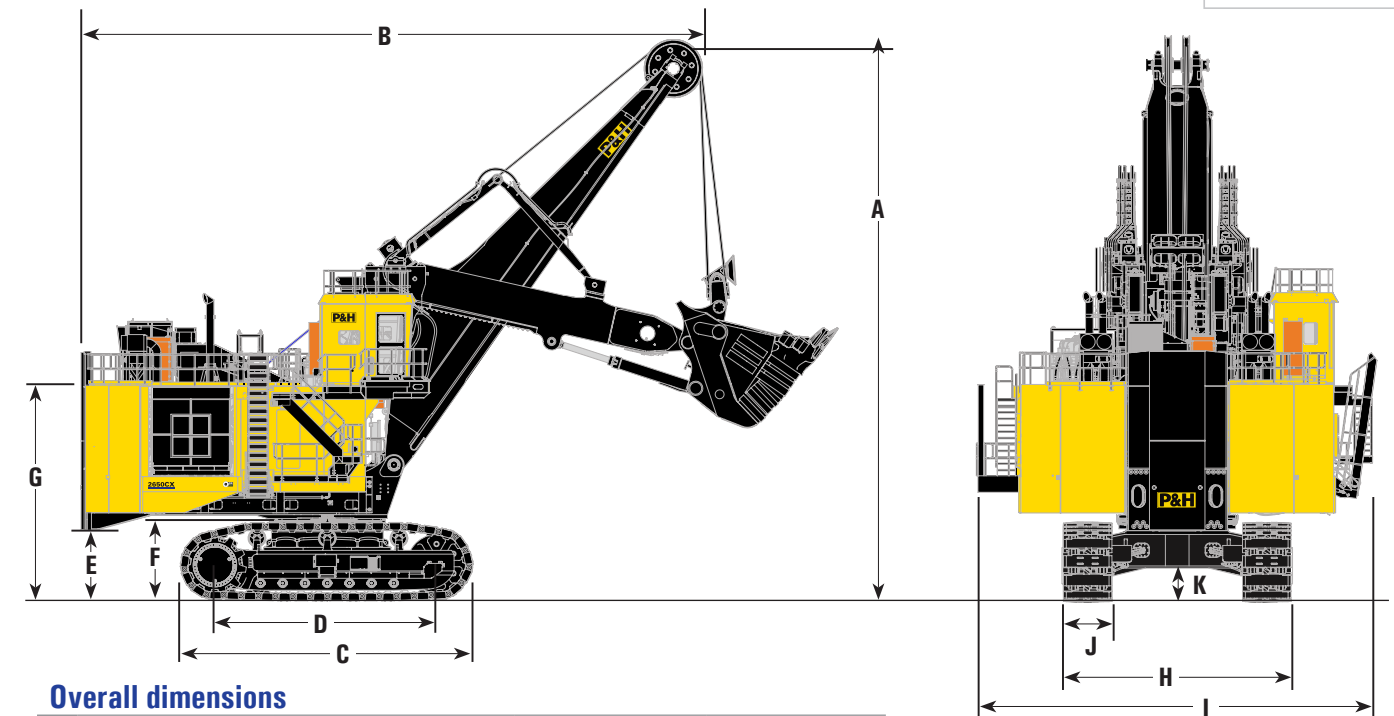

Overall dimensions

A	Boom point height	19.0 m	62.2 ft
B	Counterweight to boom point length	21.0 m	68.9 ft
C	Crawler length	9.89 m	32.45 ft
D	Center of idler to center of tumbler	7.48 m	24.54 ft
E	Height - ground to bottom of counterweight	2.38 m	7.81 ft
F	Height of crawlers	2.65 m	8.69 ft
G	Deck height	7.24 m	23.75 ft
H	Width of crawlers	7.6 m	25.0 ft
I	Overall machine width	14.13 m	46.36 ft
J	Crawler shoe width (standard size)	1.6 m	5.3 ft
K	Height - ground to carbody	1.13 m	3.69 ft

Machinery house layout

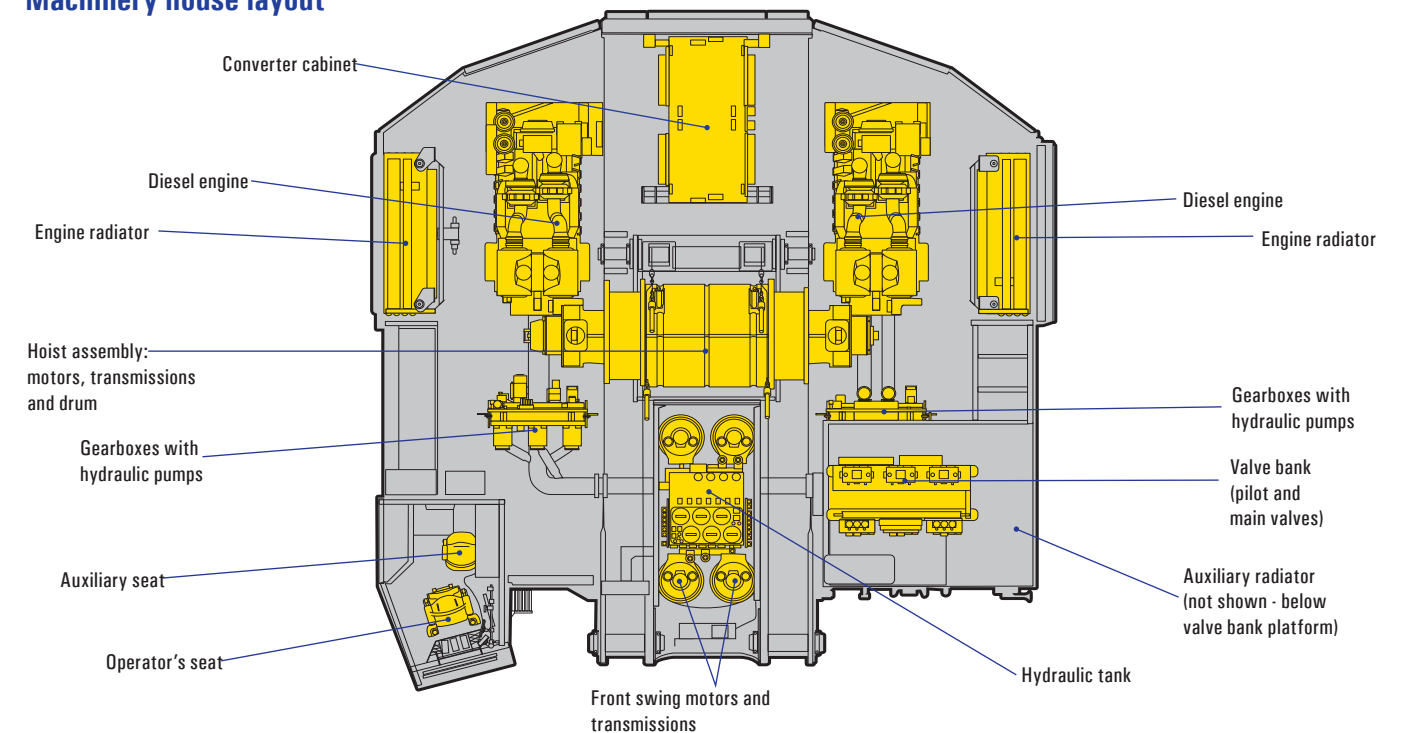

Control system—LINCS II**LINCS II**

Microprocessor based modular design Vehicle Control Unit with monitoring and diagnostics including integrated data logging and storage

LINCS II uses a dash mounted full color touchscreen display as the operator interface: out of range conditions will cause an audible alarm along with a message screen that is color coded to indicate severity

In addition, the touch-screen display provides repair technicians with operational data and fault messages

Operator's cab

Internal cab dimensions

Length	2,450 mm (96.5 in)
Width	1,845 mm (72.5 in)
Height	2,320 mm (91.3 in)

Fall-Object Protective Structure (FOPS)	ISO 3449
---	----------

Internal cab noise (high idle with AC on high)	74 dBA
---	--------

Air conditioner	5.25 kW - 18k Btu/hr
2nd optional unit	10.5 kW - 36k Btu/hr

Heater	14.6 kW - 50k Btu/hr
--------	----------------------

Fluid capacities

Fluid type	Volume (L)	Volume (gal)
Fuel tank	8,574	2,265
Engine oil	2 x 190	2 x 50
RH/LH engine high temp coolant	1,317	348
RH/LH engine low temp coolant	639	169
MPG tank	235	62
OGL tank	575	152
Hydraulic oil tank	2,082	550
RH pump drive transmission	63	16
LH pump drive transmission	58	15
Propel gearcase	2 x 227	2 x 60
Swing gearcase	4 x 76	4 x 20
Crowd gearcase	530	140
Hoist gearcase	515	136

Clamshell bucket

Nominal Payload	59 mt	65 st
Standard HD bucket @ 1.9t/m ³ (2:1 heaped)	31.1 m ³	40.7 yd ³
Lip width	5,080 mm	200 in
Weight without wear package	67,719 kg	149,294 lb
Weight with wear package	70,105 kg	154,554 lb
Overburden bucket	36 m ³	47.1 yd ³
Iron ore bucket	27.1 m ³	35.4 yd ³

Service station

Ground level service station

- Fuel
- Engine oil
- Engine coolant (RH)
- Multi purpose grease
- Open gear lube
- Hydraulic oil

LH deck service station

- Converter cooler
- Engine coolant (LH)

Komatsu: Revolutionizing the mining industry for a sustainable future

Product designs, specifications and/or data in this document are provided for informational purposes only and are not warranties of any kind. Product designs and/or specifications may be changed at any time without notice. The only warranties that apply to sales of products and services are Komatsu's standard written warranties, which will be furnished upon request.

Komatsu and other trademarks and service marks used herein are the property of Komatsu Ltd., Komatsu America Corp., Komatsu Mining Corp., or one of their affiliates, or the respective owners or licensees.

© 2020 Komatsu Mining Corp. All rights reserved.

EN-2650CXHS01-0420-V4

mining.komatsu