

# KOMATSU<sup>®</sup>

## S172

Forestry Quality™

S172



HARVESTING HEAD

## Unrivalled performance with large trees

A mighty head with a two-wheel feed designed for massive and challenging forest. What's more, it's exceptionally reliable and easily customised to individual needs. These are the most profit-enhancing characteristics of the new Komatsu S172.

Consider, for instance, its remarkably high productivity, one of the many reasons for which is the smart two-wheel feed with all the feed force (which is also variable) you need for the largest of trees, regardless of shape. Then we have the sensor-based Flex Friction Control, which provides the best possible stem processing and delimiting results for different tree species and diameters. The delimiting

also enhances productivity with its four moving knives complemented with a fixed knife for the delimiting of, for example, low branches.

And let's not forget the outstanding reliability, the explanations for which range from the noticeably easy servicing through the sturdy construction with a high-strength steel frame to the smart hose routing and protected head computer. Moreover, you can customise the head to suit your needs in terms of measuring, feed rollers, stump treatment and much more. So if you want a truly large head to meet extremely challenging demands – namely yours – choose the new Komatsu S172!

# TECHNICAL DATA

# S172

## Komatsu S172, highlights

- Two-wheel feed that maximises productivity in all kinds of forest
- Four moving delimiting knives, three of which are hydraulically controlled. Fixed delimiting knife mounted above the saw box for delimiting low branches
- Flex Friction Control. Knife pressure and lifting force are controlled by a sensor in the vertical knife to produce the least possible friction between stem and head
- Easy service and maintenance with optimal access to all vital components
- Smart hose routing that minimises downtime
- Well-protected head computer mounted under head hood
- Cast steel feed roller arms for maximum service life
- Option of equipping the head with either manual or automatic chain tensioning
- Choice of feed rollers for maximum customisation
- Optional colour marking and stump treatment equipment
- Optional 4-point measuring for increased measurement accuracy
- Sturdy construction, high-strength steel frame

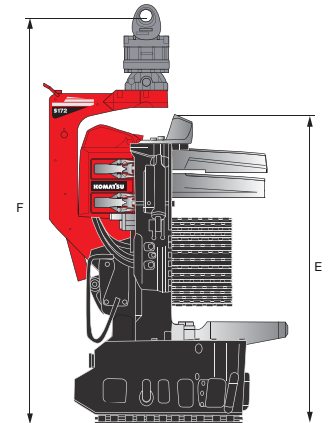
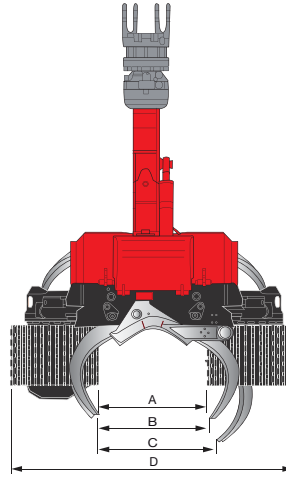

Dry weight:	from 1,675 kg (3,693 lb)
Feed rate:	0-5 m/s (0-16.4 ft/s)
Feed force, gross:	40.2 kN (9,037 lbf)
Feed roller type:	Steel rollers
Delimiting knives, max. number:	4
Delimiting diameter, tip to tip:	500 mm (19.7")
Saw bar:	90 cm (35.4")
Saw motor:	19/30 cm <sup>3</sup> /rev
Felling diameter, theoretical max.:	750 mm (29.5")
Requisite max. hydraulic flow:	300 l/min (79 gpm)
Requisite max. hydraulic pressure:	28 MPa (4,061 psi)

<b>A</b> Roller opening, max.	713 mm (28.1")
<b>B</b> Opening forward knives, max.	757 mm (29.8")
<b>C</b> Opening rear knives, max.	772 mm (30.4")
<b>D</b> Width, max.	1,937 mm (76.3")
<b>E</b> Height to vertical knife	1,748 mm (68.8")
<b>F</b> Height including rotator	2,222 mm (87.5")

NB: Refers only to one of several possible dimensional combinations and the head's weight is dependent on equipment options.

### EQUIPMENT OPTIONS

Standard and extra equipment are market-dependent and vary between countries. Your sales representative has an up-to-date list of what is included.

Technical data/dimensions vary depending on optional equipment selected. Specifications and designs are subject to alteration without prior notice. Photos, diagrams and figures do not always show the standard configuration.



### ZONE OF APPLICATION

