

Model 1500 Mine Air Systems Technical Data

Performance benefits

- Rugged design specifically engineered for surface mining application
- Modular design for unmatched change-out speed and convenience
- Unique weather-sealed roofplate eliminates dust and water leaks into the cab and electrical room
- Stainless steel construction
- Designed for maintenance ease
- Designed specifically for ozone friendly R-407C refrigerant
- High efficiency air filters to suit each application
- Industrial-sized super efficient filter-pressurizer with air pre-cleaner
- Smooth and quiet scroll-technology compressor

P&H brand Mine Air Systems (MAS) climate control units provide air conditioning, heating, filtration and pressurization comforts to the operator's cab. Advanced MAS climate control technology sustains ultimate operator comfort and efficiency by automatically maintaining an even floor-to-roof temperature and a regulated, filtered air flow.

The MAS 1500 is manufactured and distributed worldwide by Komatsu Mining and will control the climate conditions of operator cabs and electrical rooms on large electric mining shovels, drills and draglines.

Through modular design, an entire MAS unit can be changed out in just 60 minutes. Individual electrical and control modules can be replaced in as little as ten minutes with no special tools.



For more information, contact
a local Komatsu Mining
representative or visit
mining.komatsu

Applications

The MAS model 1500 unit is a complete operating system requiring only a power supply to function. Ideal applications include shovels, drills and draglines. The unit can be deck or roof mounted. Additional considerations:

- Installation expertise required
 - Electrician
 - Welder
 - Mechanic
 - Air conditioning experience
- Power requirement
 - 30 amp: 480/3/60 AC or
 - 40 amp: 380/3/50 AC

Components/options

The following are components/options available on the MAS model 1500 unit:

- Filter – pressurizer with air pre-cleaner
- Silica dust and diesel emission packages
- Cooling only unit
- Mine logic control – digital programmable control with self diagnostic feature

Model 1500 installation (roof mount application shown)

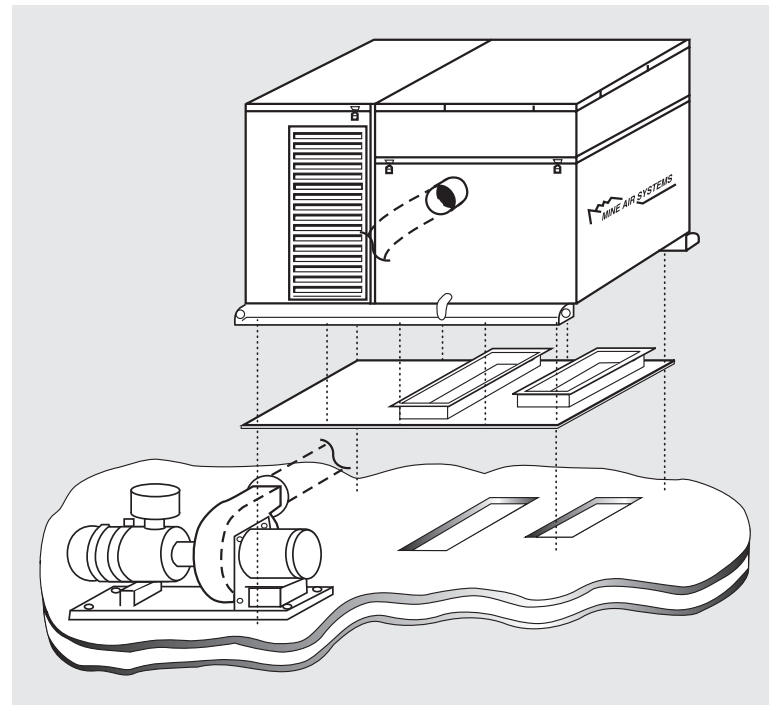

Technical characteristics

Feature	Specification
Description	Roof or beside-the-cab mounted climate control system with optional remote mounted dedicated blower pressurizer
Electrical	460 VAC, 3 Phase, 60 Cycle 380 VAC, 3 Phase, 50 Cycle
Recirculated airflow	High speed - 1500 cfm Low speed - 1000 cfm 2 x 250 mm EC blowers
Safety controls	Field replaceable without refrigerant loss Digitally monitored low and high pressure
Compressor ROHS	Compliant scroll, hermetically sealed
Refrigerant	R-407C
Pressurization	170 cfm @ 60 Cycle with clean filter, 20% reduction at change interval Self-cleaning pre-cleaner Maintainable second stage filter cup Donaldson radial seal disposable filter element (no fasteners). Cast aluminum, high speed impeller, operating range 7" w.c.
Filters	Disposable 65% efficient in-cab filter in standard plenum configurations Custom filter plenums from 65% (Hepa 99% @ .1 micron*) to suit individual requirements *Special order only Merv 8 - Hepa
Physical size	1187 mm long x 927 mm wide x 851 mm high (46.75" long, 36.50" wide, 33.5" high)

Feature	Specification
Exchangability (modularity)	Complete system – 60 minutes Electrical module – 20 minutes Control module – 10 minutes
Switch gear	High quality contactors and thermal overloads all circuits Safety contactor, circuit breakers, auto-reset, and main reset limits-heaters Circuit breaker disconnects main, heater, control circuits
Cooling capacity	45,000 Btu/hr @ 24°C (75°F) DB/18°C (65°F) WB 19°C (67°F) WB
Capacity control	Low load idle (hot gas bypass) valve Externally equalized thermostatic expansion valve
Compressor oil	Polyolester (POE)
Heating capacity	18.0kW at 380 VAC or 480 VAC Fully proportional control from 0 to 100% of capacity (stageless)
Control	Standard Electric Controller (SEC) Analog Mine Logic Controller (MLC) Digital (optional)
Construction	Cases 16 gauge 316 stainless steel, polished finish Coils copper tube/copper fin-8 fins/in.
Weight	363 kg (800 lbs)

Model 1500 dimensions

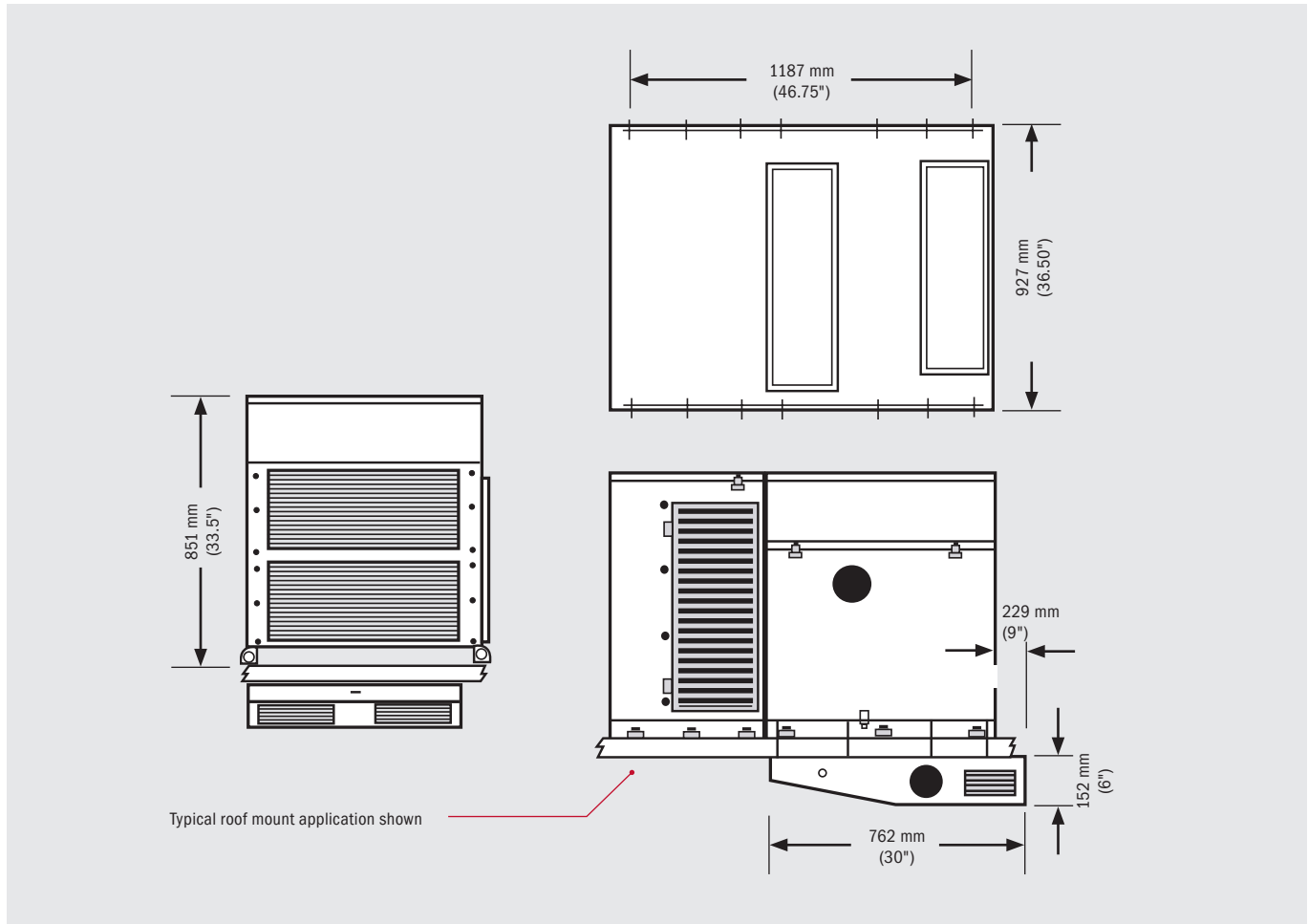

Komatsu Mining Corp. Group

mining.komatsu



Product designs, specifications and/or data in this document are provided for informational purposes only and are not warranties of any kind. Product designs and/or specifications may be changed at any time without notice. The only warranties that apply to sales of products and services are standard written warranties, which will be furnished upon request.

Komatsu, Joy, Montabert, P&H and other trademarks and service marks used herein are the property of Komatsu Ltd., Komatsu Mining Corp., or their respective owners or licensees.

© 2018 Komatsu Mining Corp. All rights reserved.