

KOMATSU

WA480-8

EPA Tier 4 Final Engine
Australia and New Zealand Specifications



Wheel loader

NET Horsepower
223 kW / 299 HP @ 2050 rpm

Operating weight
25,960 – 27,810 kg

Bucket capacity
4.6 – 6.8 m³

WA480-8

NET Horsepower

223 kW / 299 HP @ 2000 rpm

Operating weight

25,960 – 27,810 kg

Bucket capacity

4.6 – 6.8 m³



Photos may include optional equipment.

Performance, durability and fuel economy

Large capacity torque converter with lock-up:

- Quick acceleration
- Lock-up in 2nd, 3rd and 4th gear

- Komatsu Smart Loader Logic helps reduce fuel consumption with no decrease in production.
- Brake Oil Cooling system.

The Yard Loader arrangement features a 5.5 m³ genuine Komatsu high performance bucket, an improved brake cooling system and a heavier Yard Loader counter weight, and is designed to three pass typical on-highway trucks.

A powerful Komatsu SAA6D125E-7 engine provides a net output of 223 kW 299 HP with up to 20% improved fuel consumption.* This engine is EPA Tier 4 Final emissions certified.

Variable Geometry Turbocharger (VGT) uses a hydraulic actuator to provide optimum air flow under all speed and load conditions.

Komatsu Diesel Particulate Filter (KDPF) and Selective Catalytic Reduction (SCR) systems reduce particulate matter and NOx while providing automatic regeneration that does not interfere with daily operation.

Fluid neutral or better

Fuel and DEF total consumption is less than fuel consumed by the prior model.

Cooling

- Hydraulically driven, variable speed
- Auto-reversing fan is standard
- Wider core coolers resist clogging
- Swing out fan for easy cleaning

Remote boom and bucket positioners can set kick-outs from inside the cab.

Variable displacement piston pumps with CLSS provides quick response and smooth operation to maximise productivity.

Rearview monitoring system (standard)

Advanced diagnostic system continuously monitors machine operation and vital systems to identify machine issues and assist with troubleshooting.

Transmission mode select System (3 modes) allows shifting mode to be matched more efficiently to varying work applications.

Enhanced working environment:

- High capacity air suspension seat, heated
- Seat mounted EPC controls with F-N-R switch
- (2) 12V power outlets

New style of front fender is plastic for durability.

Rear full fenders (standard) are made of durable plastic and swing open for easy access to maintenance points.



Large LCD colour monitor panel:

- 7" high resolution, multi-colour screen is easy to read
- Provides "Ecology Guidance" for fuel efficient operation
- Onboard diagnostics do not require use of a laptop computer
- Multiple choice, pulldown menus are filled with useful functions

Komatsu Auto Idle Shutdown helps reduce idle time and operating costs.

External mounting of engine air filter (above rear LH fender) provides easy access for maintenance.

New bucket design: Curved leading edges and increased heel radius make the WA480-8 bucket easier to fill, whilst providing increased material retention, leading to shorter cycle times, higher fill factors and increased productivity.

The **Komtrax** telematics system is standard on Komatsu equipment with no subscription fees throughout the life of the machine. Using wireless technology, **Komtrax** transmits valuable information such as location, utilisation, and maintenance records to a PC or smartphone app. Custom machine reports are provided for identifying machine efficiency and operating trends. **Komtrax** also provides advanced machine troubleshooting capabilities by continuously monitoring machine health.

Battery isolator switch allows a technician to disconnect and lock-out the power supply before servicing the machine.

Operator Identification System can track machine operation for up to 100 operators.

*Compared to the WA480-6.

Performance features

Komatsu new engine technologies

New Tier 4 Final Engine

The Komatsu SAA6D125E-7 engine is EPA Tier 4 Final emissions certified and provides exceptional performance while reducing fuel consumption. Based on Komatsu proprietary technologies developed over many years, this new diesel engine reduces nitrogen oxides (NOx) by more than 80% when compared to Tier 4 interim levels.

Technologies Applied to New Engine

Heavy-duty aftertreatment system

This new system combines a Komatsu Diesel Particulate Filter (KDPF) and Selective Catalytic Reduction (SCR). The SCR NOx reduction system injects the correct amount of Diesel Exhaust Fluid (DEF) at the proper rate, thereby decomposing NOx into non-toxic water vapor (H₂O) and nitrogen gas (N₂).

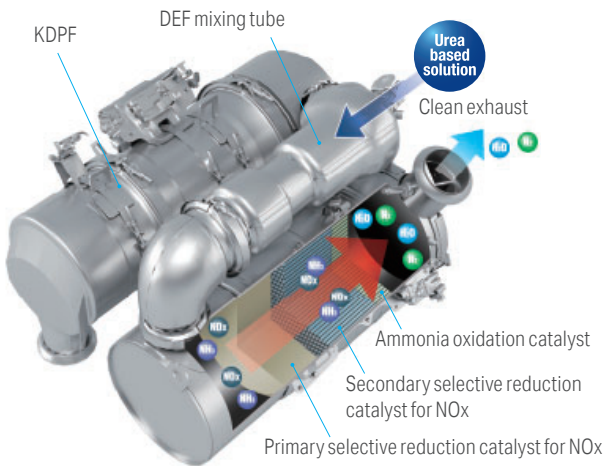

Heavy-duty cooled Exhaust Gas Recirculation (EGR) system

The system recirculates a portion of exhaust gas into the air intake and lowers combustion temperatures, thereby reducing NOx emissions.

EGR gas flow has been decreased for Tier 4 Final with the addition of SCR technology. The system dramatically reduces NOx, while helping cut fuel consumption below Tier 4 Interim levels.

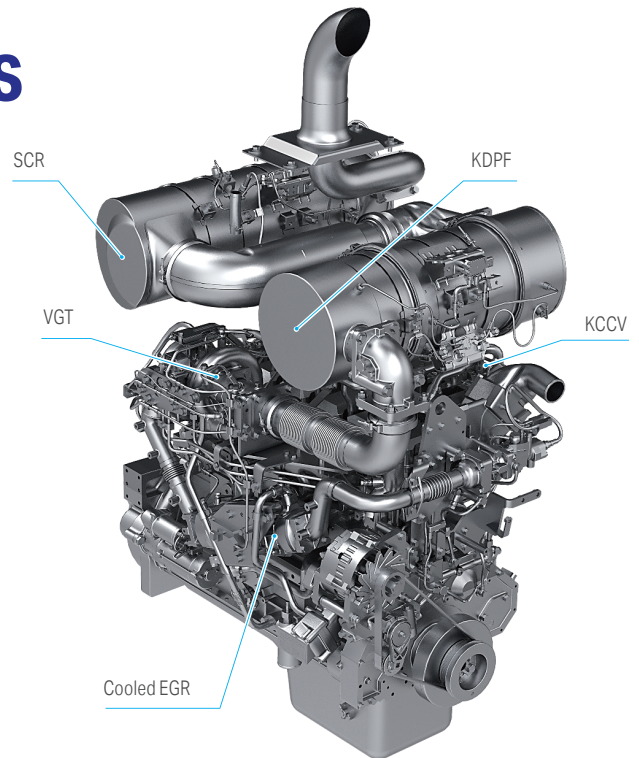
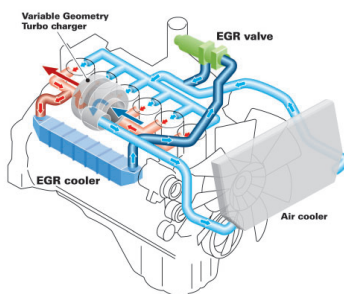

Advanced Electronic Control System

The electronic control system performs high-speed processing of all signals from sensors installed in the vehicle providing total control of equipment. Engine condition information is displayed on the monitor inside the cab, providing necessary information to the operator. Additionally, managing the information via Komtrax helps customers keep up with required maintenance.

Variable Geometry Turbocharger (VGT) system

The VGT system features proven Komatsu design hydraulic technology for variable control of air-flow and supplies optimal air according to load conditions. The upgraded version provides better exhaust temperature management.

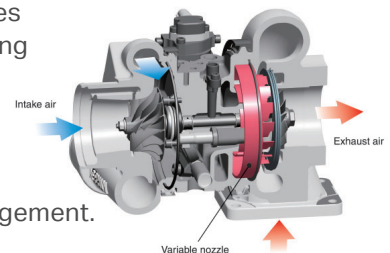

Heavy-duty High-Pressure Common Rail (HPCR) fuel injection system

The system is designed to achieve an optimal injection of high-pressure fuel digitally, thereby bringing near complete combustion to reduce PM emissions.

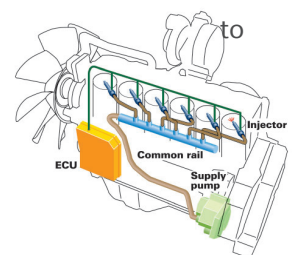

Komatsu Smart Loader Logic

The WA480-8 provides Komatsu Smart Loader Logic, an engine control system. This technology creates enough torque for each work phase. For example, engine torque needs are higher for digging in V-shape loading, but less when driving with an empty bucket. This system optimises the engine torque for all applications to minimise fuel consumption. Komatsu Smart Loader Logic functions automatically and doesn't interfere with operation, saving fuel without decreasing production.

Large-capacity torque converter

The Komatsu designed power train has a large capacity torque converter for optimum efficiency. The WA480-8 has greater productivity in V-shape loading applications because the increased tractive effort does not require full throttle. The improved hill climbing ability allows the WA480-8 to up-shift gears faster because of improved acceleration. The WA480-8 can achieve higher gear ranges and maintain higher travel speed when working in load-and-carry applications. In most applications, production is increased and fuel consumption is reduced, resulting in improved fuel efficiency.

Enhanced lock-up

The Komatsu designed torque converter with lock-up is standard on the WA480-8. The lock-up function activates in 2nd, 3rd and 4th gears. The lock-up torque converter is effective for both load and carry application and V-shape loading which uses lower gears. Komatsu SmartLoader Logic reduces the clutch engagement shock of lock-up by controlling engine torque. The lock-up torque converter combined with Komatsu Smart Loader Logic results in low fuel consumption and high travel speeds in load and carry and even some V-cycle loading applications.

New E-light mode

is activated in the monitor panel for the lowest possible fuel consumption. When activated, the engine matches power to the working conditions, for higher fuel efficiency. The work equipment and steering pumps are electronically controlled to prevent waste and deliver the exact amount required.

Engine power select system

this wheel loader offers three selectable operating modes — E, P, and E-light.

- E Mode: This mode provides maximum fuel efficiency for general loading.
- P Mode: This mode provides maximum power output for hard digging operation or hill climbing.



- 1 Dual mode engine power selection switch
- 2 Transmission shift mode selector switch
- 3 Torque converter lock-up switch
- 4 Automatic digging ON/OFF switch

Automatic transmission with mode select system

this operator controlled system allows the operator to select manual shifting or two levels of automatic shifting (low, and high). Auto L mode is for fuel saving operation with the gear shift timing set at lower speeds than Auto H mode. Therefore Auto L mode keeps the engine in a relatively low rpm range for fuel conservation while yielding required tractive force by operator depressing the accelerator pedal.

Variable Displacement Piston Pump and CLSS

The variable displacement piston pump combined with the Closed-centre Load Sensing System (CLSS) delivers hydraulic flow just as the job requires preventing wasted hydraulic flow. Minimised loss contributes to better fuel economy.

Komatsu Auto Idle Shutdown

In order to reduce idle time, Komatsu offers Komatsu Auto Idle Shutdown. This function will shut the engine off and apply the parking brake and hydraulic lock after a preset idle time limit. This time limit can be set by the operator or service technician and may range from 3 minutes to 60 minutes.

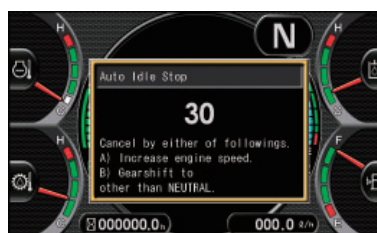

Operator environment



Photos may include optional equipment.

New operator seat with electronic pilot control (EPC) levers

A new air suspension seat provides enhanced support on rough roads and dampens machine vibrations, providing a more comfortable ride for the operator. An EPC lever console is integrated in the seat and moves with the seat. The angle of the armrest is fully adjustable for optimum operator comfort. A secondary F-N-R switch is incorporated in work equipment lever configurations. A heated seat is standard.



Tiltable / Telescopic Steering Wheel (Optional)

The operator can both tilt and telescope the steering wheel to allow maximum comfort and control. The two spoke steering wheel allows maximum visibility of the monitor panel and the forward work environment.



Low noise design

Operator's ear noise level : 72 dB(A)*
 Dynamic noise level (outside): 112 dB(A)**

The large cab is mounted with Komatsu's unique ROPS/FOPS viscous mounts. The low-noise engine, hydraulically driven fan, and hydraulic pumps are mounted with rubber cushions, and the cab sealing is improved to provide a quiet, low-vibration, dustproof, and comfortable operating environment.

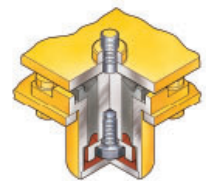

* ISO 6396: 2008
 ** ISO 6395: 2008

Advanced Joystick Steering System (AJSS)

Allows steering and directional travel to be controlled by wrist and finger control to minimise operator fatigue in high duty cycle applications. AJSS allows for full speed travel speed while maintaining precise steering and control.

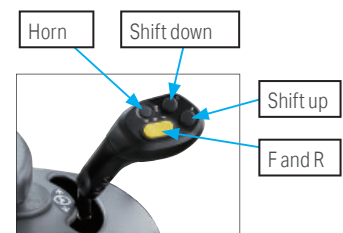



Photos may include optional equipment.

Engine shutdown secondary switch

the engine stop switch is incorporated to allow shutdown of the machine when accessing the key switch is not possible.



Engine shut down secondary switch

Rear view monitoring system (standard)

the operator can view the rear of the machine with a full colour monitor that is located on the right side of the cab. This monitor can be always on or only on when the loader goes into reverse. Visual guidelines can also be added for more convenience.

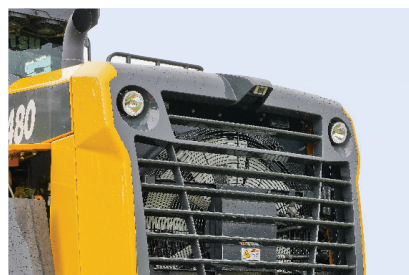

Auxiliary input (MP3 Jack) 12 V outlets

An Aux input for digital devices is standard as well as two 12 volt outlets. These are all located on the front of the right hand console.

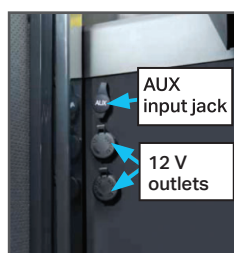

Working environment



Easy entry and egress

the WA480-8 has an inclined ladder with wide steps and hand holds to ease entry and exit from the cab.

Remote bucket and boom positioner

the operator can set the bucket angle and remote boom positioner from the cab. Both upper and lower boom positions are adjustable in the cab with the push of a button. The bucket positioner can memorise three horizontal settings, allowing the operator to easily change attachments without having to reset the bucket position. In each horizontal setting, the operator can adjust the setting with the switch in the cab. This can help save the operator time when changing attachments.



Remote positioner switch
Boom / Bucket

Automatic kick-down

the WA480-8 has the ability to automatically shift down to F1. This can be activated through the monitor.

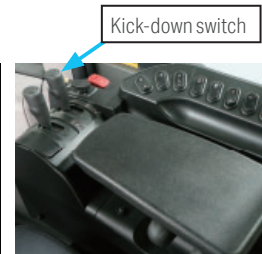

Electronically controlled suspension system

The Electronically Controlled Suspension System (ECSS) or ride control system uses an accumulator which minimises boom arm shock, giving the operator a much smoother ride. This reduces operator fatigue and reduces material spillage during load and carry operations. ECSS is speed sensitive, meaning that the boom won't move during stationary digging. ECSS is standard on the WA480-8.

New bucket design

the newly designed bucket improves overall machine productivity. Generous curves on the side wall and wrap improve pile penetration and make it easy to fill. They also improve material retention in carry operations.



High resolution 7-inch colour LCD monitor

The machine monitor display various machine information and allows for various settings of the machine. The LCD monitor is a 7-inch colour TFT-LCD and displays maintenance information, operation record, Ecology Guidance record, and other machine data. The switch panel is used to select various screens and the air conditioner control screen. By using the switch panel, you can display various user menus on the LCD screen and adjust the machine settings.

Machine monitor

- 1 LCD unit
- 2 LED unit
- 3 Engine tachometre
- 4 Speedometre
- 5 Ecology gauge
- 6 Air conditioner display
- 7 Shift indicator
- 8 Engine coolant temperature gauge
- 9 Hydraulic oil temperature gauge
- 10 Torque converter oil temperature gauge
- 11 Fuel gauge
- 12 Message pilot lamp
- 13 Pilot lamps
- 14 DEF level gauge

Switch panel

- 1 Air conditioner switches / Numeral key pad
- 2 Function switches

Visual user menu

Pressing the menu switch on the switch panel displays the user menu screen. The menus are grouped for each function, and use easy-to-understand icons which enable the machine to be operated intuitively.



- 1 Energy saving guidance
- 2 Load metre setting (optional)
- 3 Machine settings
- 4 Aftertreatment devices regeneration
- 5 SCR information
- 6 Maintenance
- 7 Monitor setting
- 8 Mail check



Operator identification function

An operator identification (ID) can be set for each operator, and used to manage operation information of individual machines as Komtrax data. Data sent from Komtrax can be used to analyse operation status by operator as well as by machine.



Machine monitor with troubleshooting function to minimise downtime

Various metres, gauges and warning functions are centrally arranged on the machine monitor. The monitor simplifies start-up inspection and promptly warns the operator with a lamp and buzzer if any abnormalities should occur. In addition, countermeasures are indicated in 4 levels to ensure safety and help prevent the machine from having major problems. Replacement times for oil and filters are also indicated.



Maintenance features

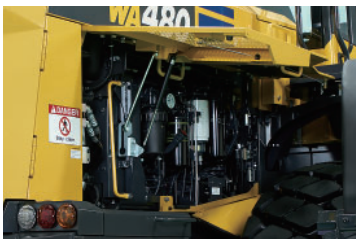

Side-opening gull-wing engine doors

the large gull-wing type engine doors require less effort to open and close thanks to gas assisted struts. The doors provide wide areas of access for ease of daily maintenance. Large steps on each side of the frame enhance accessibility.



Easy access wide core radiator

the door swings open for easy cleaning. The coolers feature wide spacing of the cooling fins to reduce clogging.



Auto reversing fan

the engine cooling fan is driven hydraulically. It can be set to reverse automatically during operation. Fan reverse mode and timing can be controlled through the monitor.

DEF tank

The DEF tank is located on the right hand side of the machine behind a ladder for easy access. An external sight gauge aids in preventing overflow and spillage while refilling. A new magnetised holder is provided for added convenience.



Lockable battery isolation switch and jump start receptacle

The lockable battery isolator is located on the right-hand side at the rear of the machine. This can be used to disconnect power when performing service work on the machine, and personal tag-out devices can be utilised to ensure compliance to site and safety regulations. The jump start receptacle is also located here.

Engine compartment

The WA480-8 engine compartment is designed for easy serviceability. Placement of maintenance items, such as filters, dipsticks, oil fill locations, and aftertreatment devices is all very intuitive.

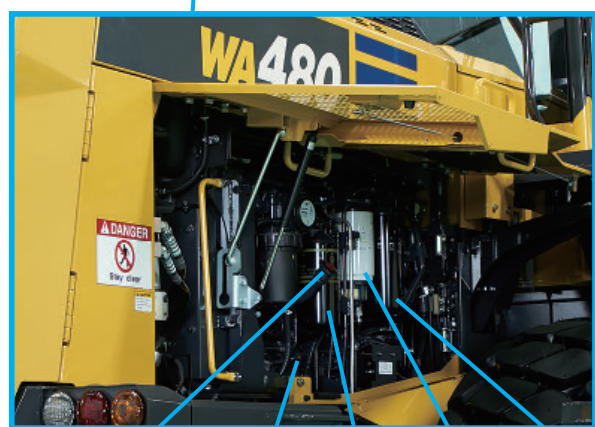
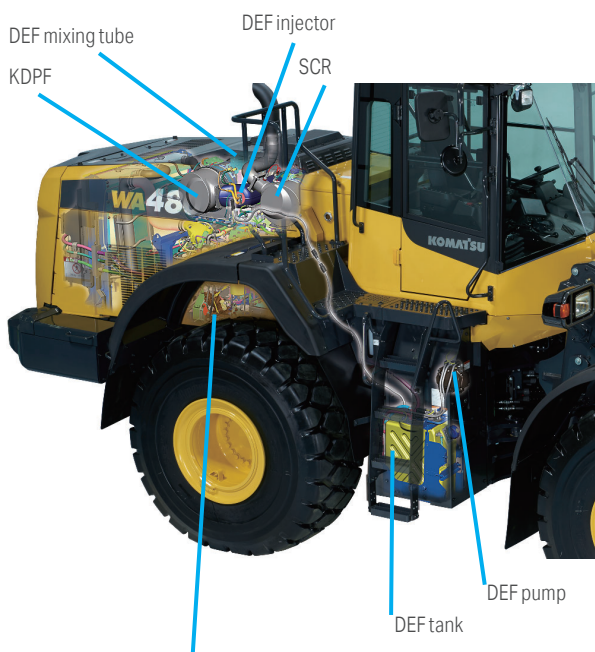

Rear full fenders (standard)

the WA480-8 has a rear full fender standard. The plastic rear fenders open outward, keeping the force to open the engine doors low, even when there is mud or snow on the fenders. The fenders swing far out of the way to give the technician easy access to the engine compartment. Mudflaps are also included on the rear fenders.



Air conditioner filter

the inside and outside air conditioner filters can be replaced easily without using a tool. The outside filter is located behind a lockable door for security.



Inside air filter



Outside air filter

LED taillights

LED brake lights and LED reverse lights provide long bulb life.



Air cleaner

The air cleaner is located on the left side platform for easy access.



Maintenance information

"Maintenance time caution lamp" display

When the remaining time to maintenance becomes less than 30 hours*, the maintenance time monitor appears. Pressing the menu switch displays the maintenance screen.

* The setting can be changed within the range between 10 to 200 hours.

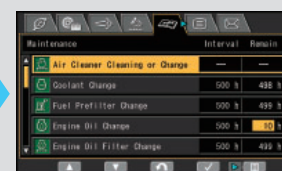

Maintenance screen

Supports the DEF level and refill timing

The DEF level gauge is displayed continuously on the monitor screen. In addition, when the refill timing is reached, the DEF low level guidance appears as a pop up display to inform the operator in real time.



DEF level gauge

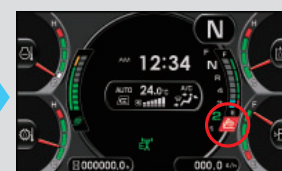

DEF low level guidance

Komtrax Equipment Monitoring

Get the whole story with



What

- Komtrax is Komatsu's remote equipment monitoring and management system Komtrax continuously monitors and records machine health and operational data
- Information such as fuel consumption, utilisation, and a detailed history lowering owning and operating cost

Who

- Komtrax is standard equipment on all Komatsu construction products

When

- Know when your machines are running or idling and make decisions that will improve your fleet utilisation
- Detailed movement records ensure you know when and where your equipment is moved
- Up to date records allow you to know when maintenance is due and help you plan for future maintenance needs

Where

- Komtrax data can be accessed virtually anywhere through your computer, the web or your smart phone
- Automatic alerts keep fleet managers up to date on the latest machine notifications

Why

- Knowledge is power – make informed decisions to manage your fleet better
- Knowing your idle time and fuel consumption will help maximise your machine efficiency
- Take control of your equipment – any time, anywhere.



KOMTRAX
For construction and compact equipment.

KOMTRAX Plus
For production and mining class machines.

Specifications

Engine

Model	Komatsu SAA6D125E-7*
Type	Water-cooled, 4-cycle
Aspiration	Turbo-charged, after-cooled, cooled EGR
Number of cylinders	6
Bore	125 mm
Stroke	150 mm
Piston displacement	11.04 ltr
Horsepower:	
SAE J1995	Gross 224 kW
ISO 9249 / SAE J1349	Net 223 kW
Rated rpm	2000
Governor	All-speed, electronic
Fan drive method for radiator cooling	Hydraulic
Fuel system	Direct injection
Lubrication system:	
Method	Gear pump, force-lubrication
Filter	Full-flow type
Air cleaner	Dry type with double elements and dust evacuator, plus dust indicator

*EPA Tier 4 Final emissions certified

Transmission

Torque converter	3-elements, 1-stage, 2-phase
Transmission	Automatic full-powershift, countershaft type

Travel speed	Forward*	Reverse*
1st	7.3 km/h	7.5 km/h
2nd	12.7 km/h (13.3 km/h)	13.1 km/h (13.8 km/h)
3rd	22.2 km/h (23.8 km/h)	22.9 km/h (24.5 km/h)
4th	35.4 km/h (38.5 km/h)	36.6 km/h (39.0 km/h)

*P-mode Measured with 26.5-R25 tyres (): Lock-up clutch ON

Axles and final drives

Drive system	Four-wheel drive
Front	Fixed, semi-floating
Rear	Centre-pin support, semi-floating, 26° total oscillation
Reduction gear	Spiral bevel gear
Differential gear	Conventional type
Final reduction gear	Planetary gear, single reduction

Brakes

Service brakes	Hydraulically actuated wet disc brakes, incorporating brake cooling system
Parking brake	Wet disc brake
Emergency brake	Parking brake is commonly used

Steering system

Type	Articulated type, fully-hydraulic power steering
Steering angle	35° each direction (40° to max end stop)
Minimum turning radius at the centre of outside tyre	6630 mm

Hydraulics

Steering system	
Hydraulic pump	Piston type
Capacity	195 ltr/min at rated rpm
Relief valve setting	24.5 MPa 250 kgf/cm ²
Hydraulic cylinders	
Type	Double-acting, piston type
Number of cylinders	2
Bore x stroke	90 mm x 441 mm
Loader control	
Hydraulic pump	Piston pump
Capacity	260 ltr/min at rated rpm
Relief valve setting	34.3 MPa 350 kgf/cm ²
Hydraulic cylinders:	
Type	Double-acting, piston type
Number of cylinders—bore x stroke	
Lift cylinder	2- 140 mm x 881 mm
Bucket cylinder	1- 180 mm x 572 mm
Control valve	2-spool type
Control positions:	
Boom	Raise, hold, lower, and float
Bucket	Tilt-back, hold, and dump
Hydraulic cycle time (rated load in bucket):	
Raise	6.4 s
Dump	1.9 s
Lower (Empty)	3.8 s

Service refill capacities

Cooling system	81 ltr
Fuel tank	380 ltr
Engine	38 ltr
Hydraulic system	173 ltr
Axle front	59 ltr
Axle rear	59 ltr
Torque converter and transmission	65 ltr
DEF tank	36 ltr

Bucket selection guide

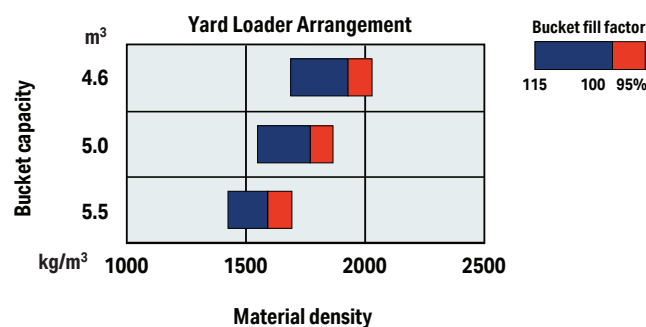

Specifications

Dimensions

Tread	Standard Loader	2300 mm
	Yard Loader	2314 mm
Width over standard tyres	Standard Loader	3010 mm
Width over 775/65R29 tyres	Yard Loader	3150 mm
A Wheelbase		3450 mm
B Hinge pin height, max. height		4535 mm
C Hinge pin height, carry position	SAE	585 mm
D Ground clearance		555 mm
E Hitch height		1240 mm
F Overall height, top of the stack		3250 mm
G Overall height, ROPS cab		3605 mm
H Overall height, top of air brake cooling	Yard Loader	3630 mm

Measured with 26.5-5R25(L-4)(2WW2625R7C) and KAL request spec.

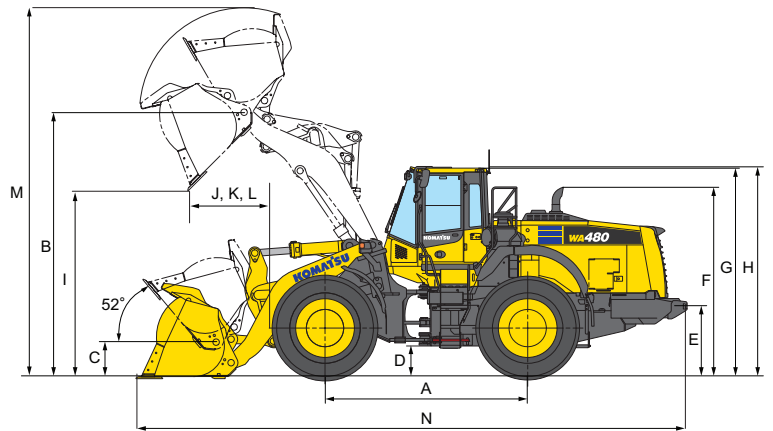

Standard Boom

	General Purpose Bucket Pin On	Loose Material Bucket Pin On	Loose Material Bucket Pin On
	Bolt-on Cutting Edge	Bolt-on Cutting Edge	Bolt-on Cutting Edge
Bucket capacity: heaped	4.6 m ³	5.0 m ³	5.5 m ³
Bucket capacity: struck	4.0 m ³	4.3 m ³	5.0 m ³
Bucket width *with bucket side guard	3170 mm	3170 mm	3190 mm
Bucket weight	2387 kg	2458 kg	2608
I Dumping clearance, max. height and 45° dump angle*	3165 mm	3055 mm	3025 mm
J Reach at max. height and 45° dump angle*	1440 mm	1580 mm	1600 mm
K Reach at 2130 mm 7' clearance and 45° dump angle*	2165 mm	2235 mm	2240 mm
L Reach with arm horizontal and bucket level*	3080 mm	3255 mm	3274 mm
M Operating height (fully raised)	6280 mm	6405 mm	6375 mm
N Overall length (bucket on ground)	9375 mm	9475 mm	9575 mm
Loader clearance circle (bucket at carry, outside corner of bucket)	15420 mm	15475 mm	15525 mm
Digging depth: 0°	90 mm	60 mm	90 mm
Digging depth: 10°	365 mm	370 mm	400 mm
Static tipping load: straight	20205 kg**	211200 kg**	21320 kg
Static tipping load: 40° full turn	17540 kg**	18190 kg**	18370 kg
Breakout force	206 kN	193 kN	182 kN
	21000 kgf	19700 kgf	18530 kgf
Operating weight	25960 kg**	27430 kg**	27580 kg

* At the end of tooth or B.O.C.E. (Bolt on cutting edge)

All dimensions, weights, and performance values based on ISO 7131, ISO 14397-1 and ISO 7546 standards.

Static tipping load and operating weight shown include lubricant, coolant, full fuel tank, ROPS cab, and operator. Machine stability and operating weight affected by counterweight, tyre size, and other attachments.

** Effective from S/N A48081, 100438

Weight and dimension changes

Tyres or attachments	Operating weight	Tipping load straight	Tipping load full turn	Width over tyres	Ground clearance	Change in vertical dimensions
26.5-25-20PR(L-4)	+340 kg	+239 kg	+211 kg	3010 kg	525 kg	0 kg
Remove additional counterweight	-378 kg	-924 kg	-769 kg			

Standard equipment

- 2-spool valve for boom and bucket control
- Advanced Joystick Steering System (AJSS)
- Alternator, 90 A
- Auto shift transmission with mode select system
- Auto lube system
- Automatic digging system
- Automatic hydraulic-driven fan with automatic reverse rotation
- Back-up alarm
- Batteries, 140 Ah/12V (2), 930 CCA
- Battery disconnect with lockout
- Boom Kick-out, in-cab adjustable
- Bucket Positioner, in-cab adjustable, 3 positions
- Colour rear view camera and monitor
- Counterweight, standard and additional
- Cutting edge (bolt-on type)
- Electronically Controlled Suspension System (ECSS)
- Engine, Komatsu SAA6D125E-7 diesel
- Engine shut-off system, electric
- EPC fingertip controls with F-N-R switch, two levers
- Equipment Management Monitoring System (EMMS)
 - Lights (central warning, brake oil pressure, engine oil pressure, parking
- brake, cooling fan reverse, KDPF restriction, seat belt caution, Komtrax message
 - Gauges (Engine water temperature, ecology, fuel level, DEF level, hydraulic oil temperature, speedometre/tachometre)
- Front fenders
- Fuel pre-filter with water separator
- Horn, electric
- Integrated Load Metre (2 lever only)
- Komatsu SmartLoader Logic
- Komatsu Auto Idle Shutdown
- Komtrax Level 5
- Lift cylinders and bucket cylinder
- Lights
 - Back-up light, LED
 - Stop and tail light, LED
 - Turn signal lamps, 2 front and 2 rear with hazard switch
 - Working lights, halogen, 2 front cab mount
 - Working lights, halogen, 2 front fender mount
 - Working lights, halogen, 2 rear grill mount
- Loader linkage with standard lift arm
- Lock-up torque converter
- Parking brake, electric
- Radiator, wider core
- Radiator mask, swing out
- Rear full fenders
- Rear view mirrors, outside (2) inside (2)
- Rims for 26.5-25 tyres
- ROPS/FOPS Cab Level 2
 - 2 x DC12V electrical outlets
 - Ashtray
 - Auto air conditioner
 - Cigarette lighter, 24V
 - Colour LCD/TFT multi-monitor
 - Cup holder
 - Floor mat
 - Operator seat, reclining, air suspension type, heated
 - Radio, AM/FM with AUX input jack
 - Rear defroster, electric
 - Seatbelt, 2-point retractable, 76mm 3" width
 - Space for Lunch box
 - Steering wheel, tilt and telescopic
 - Sun visor, front window
 - Windshield washer and wiper, front with intermittent
 - Windshield washer and wiper, rear
- Service brakes, wet disc type
- Starting motor, 7.5 kW
- Transmission, 4 forward and 4 reverse
- Vandalism protection kit, padlocks for battery box (2)

Optional equipment

- Auxiliary steering (SAE)
- Block heater and oil pan heater
- Engine pre-cleaner with extension
- Limited slip differential (FandR)
- Load Metre Printer (2 lever only)
- Monolever loader control with transmission F-N-R switch (not compatible with AJSS)
- Various tyre options, radial and bias
- Various bucket options

Product designs, specifications and/or data in this document are provided for informational purposes only and are not warranties of any kind. Product designs and/or specifications may be changed at any time without notice. The only warranties that apply to sales of products and services are Komatsu's standard written warranties, which will be furnished upon request.

Komatsu and other trademarks and service marks used herein are the property of Komatsu Ltd., Komatsu Australia Pty Ltd., Komatsu New Zealand Limited, Komatsu America Corp., Komatsu Mining Corp., or one of their affiliates, or the respective owners or licensees.

KOMATSU

[komatsu.com.au](https://www.komatsu.com.au)

