

KOMATSU®

WA320PZ-6

HORSEPOWER
Gross: 127.3 kW 171 HP @ 2000 rpm
Net: 125 kW 167 HP @ 2000 rpm

BUCKET CAPACITY
2.7 m³ 3.5 yd³

ecot3

WA
320



Photo may include optional equipment.

WHEEL LOADER
WITH PARALLEL Z BAR LINKAGE

WALK-AROUND

HORSEPOWER
 Gross: 127.3 kW 171 HP @ 2000 rpm
 Net: 125 kW 167 HP @ 2000 rpm
BUCKET CAPACITY
 2.7 m³ 3.5 yd³

High Productivity & Low Fuel Consumption

- High performance SAA6D107E-1 engine
 - Low fuel consumption
 - Electronically-controlled HST with variable shift control system
 - Variable traction control system
 - S-mode
- See pages 4 and 5.

Excellent Operator Environment

- HST traction control switch
 - Electrically controlled directional lever
 - Tilttable steering column
 - Low-noise designed cab
 - Pillar-less large ROPS/FOPS cab-integrated
 - Easy entry/exit, rear-hinged doors
- See pages 8 and 9.

New Komatsu Parallel PZ Linkage

- Parallel movement in both fork application and bucket application
- Excellent visibility to front attachments
- Large tilt force at maximum boom height
- Large dump angle at maximum boom height
- 2 mode bucket leveler



Photo may include optional equipment.

Increased Reliability

- Reliable Komatsu designed and manufactured components
 - Sturdy main frame
 - Maintenance-free, fully hydraulic, wet disc service and parking brakes
 - Hydraulic hoses use flat face O-ring seals
 - Cathion electrodeposition process is used to apply primer paint
 - Powder coating process is used to apply on main structure
 - Sealed DT connectors for electrical connections
- See page 6.

Harmony with Environment

- EPA Tier 3 and EU Stage 3A emission regulations certified
- Low exterior noise
- Low fuel consumption

Easy Maintenance

- "EMMS" (Equipment Management Monitoring System)
 - Easy access, gull-wing type engine side doors
 - Automatic Reversible Fan (option)
- See page 7.

HIGH PRODUCTIVITY AND LOW FUEL CONSUMPTION



High Performance Engine SAA6D107E-1 Engine

Electronic Heavy Duty Common Rail fuel injection system provides optimum combustion of fuel. This system also provides fast throttle response to match the machine's powerful tractive effort and fast hydraulic response.

Net: 125 kW 167 HP

Low Emission Engine

This engine is EPA Tier 3 emission regulations and EU Stage 3A emission regulations certified, without sacrificing power or machine productivity.

Low Fuel Consumption

The high-torque engine and Hydrostatic Transmission (HST) with maximum efficiency in the low-speed range provide low fuel consumption.

Eco Indicator

The eco indicator will help an operator to promote energy saving.



Electronically-Controlled HST Using a 1-Pump, 2-Motor System

- The 1-pump, 2-motor system allows for high-efficiency and high tractive effort. Engine power is transmitted hydraulically to a transfer case, then manually out to the differentials and out to the four driving wheels.
- HST provides quick travel response and aggressive drive into the pile. The variable displacement system automatically adjusts to the tractive effort demand to provide maximum power and efficiency.
- Full auto-shifting eliminates any gear shifting and kick-down operation to allow the operator to concentrate on digging and loading.
- When high drive torque is needed for digging, climbing or initiating movement, the pump feeds both motors. This combination makes the loader very aggressive and quick.
- Under deceleration, the HST system acts as a dynamic brake on the mechanical drive system. The dynamic brake can hold the loader in position on most workable slopes. This can be an advantage in stockpiling and ramp loading.
- As the machine moves and gains ground speed, the torque demand decreases and the low speed motor is effectively removed from the drive system by a clutch. At this point, the flow is going to the high-speed motor and the low-speed motor is not causing a drag on the system.
- An inching pedal gives the operator excellent simultaneous control of his travel and equipment hydraulic speeds. By depressing the inching pedal, drive pump flow to the motors will decrease, reducing ground speed and allowing the operator to use his accelerator to increase flow to his equipment hydraulics. Depressing the inching pedal further will activate the service brakes.

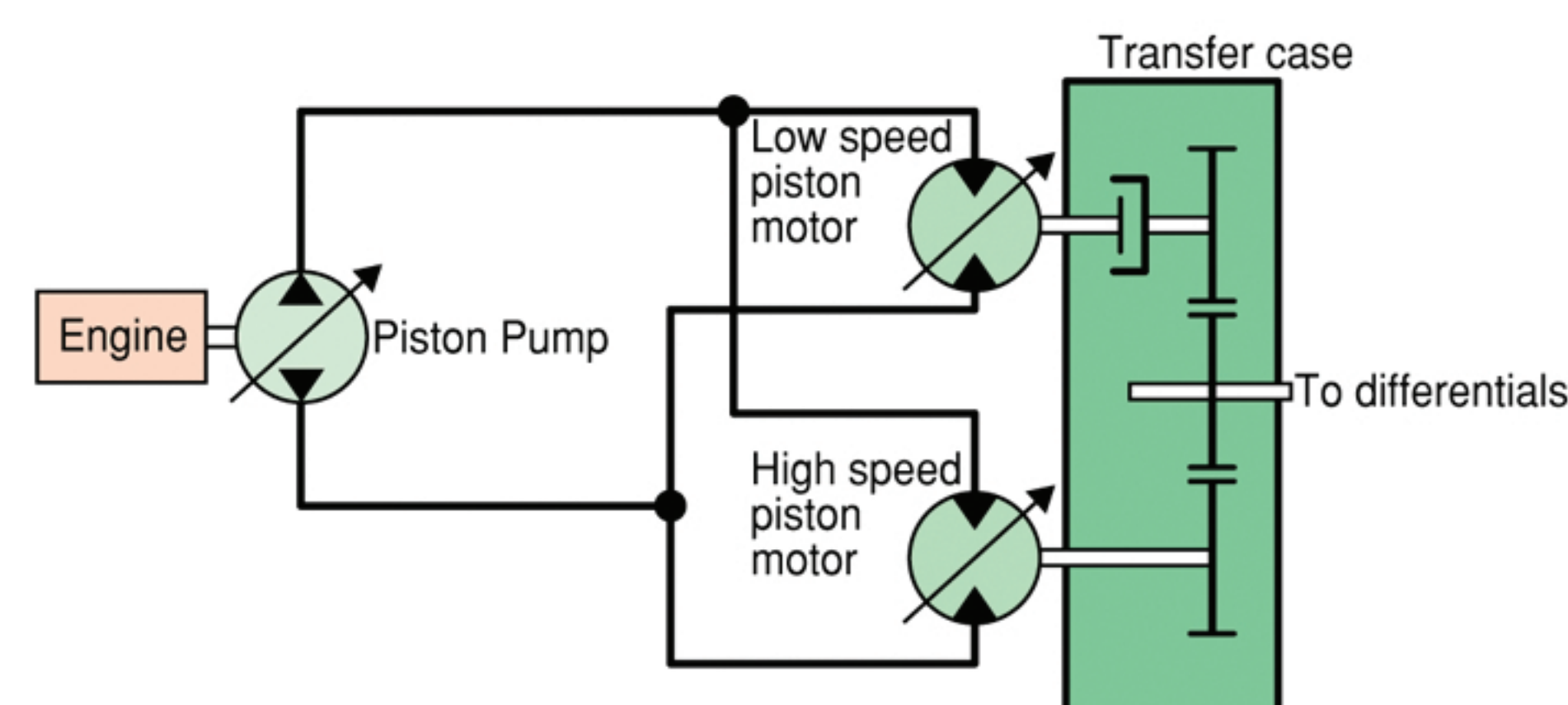

Electronically-Controlled HST with Variable Shift Control System

The operator can choose between first, second, third or fourth maximum speeds by dialing the speed range selector switch. For v-cycles, the operator can set the speed control switch to 1 or 2, which provides aggressive digging, quick response and fast hydraulics. For load and carry, select 3 or 4 which still provides aggressive digging but with much faster travel speed.

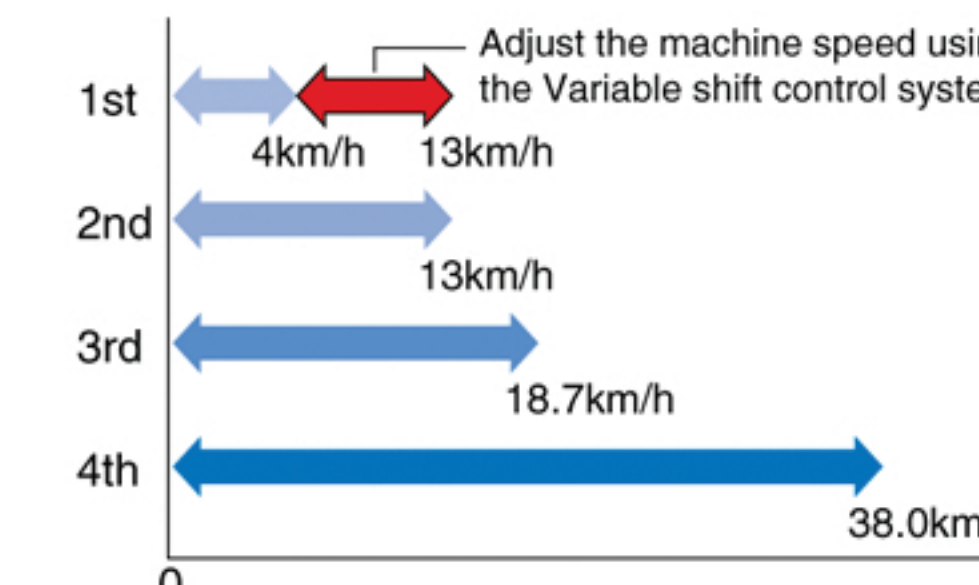

The variable shift switch allows the operator to adjust his machine speed in applications such as confined v-loading. When in 1, the operator can adjust travel speed using the variable shift switch to match machine speed and hydraulics to the distance travelled.

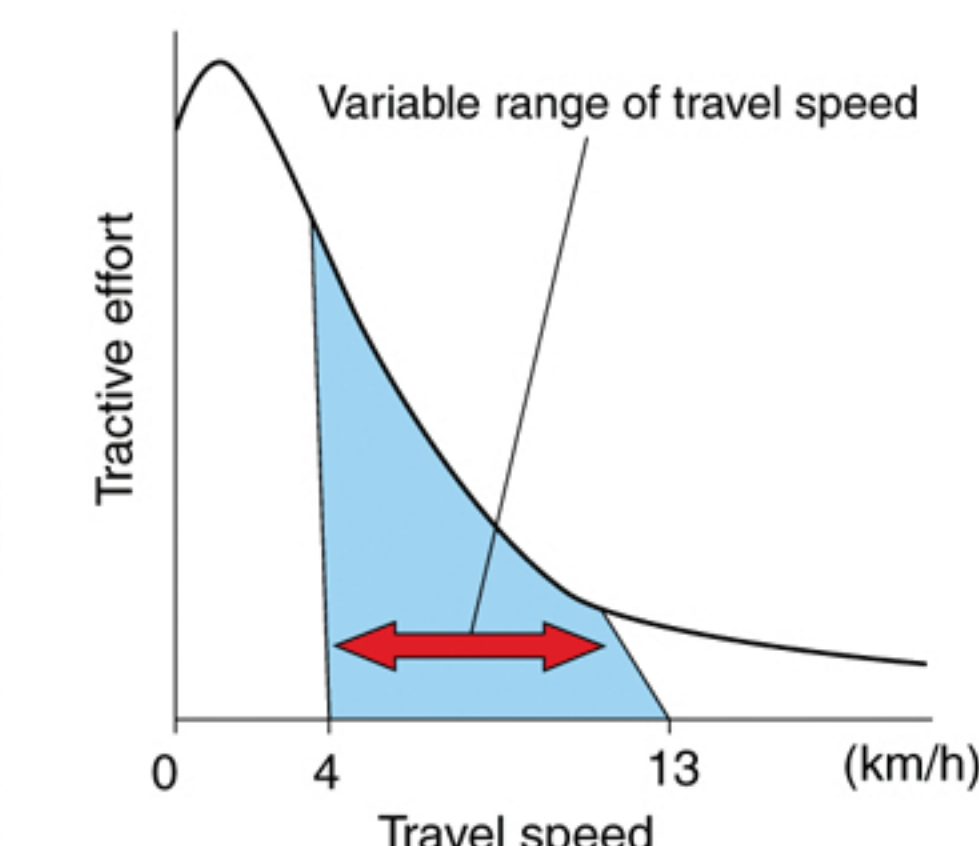

Variable Traction Control System

The tractive effort of the machine, when traveling at a low speed, can be reduced by using the traction control switch. Combined with the function of torque proportioning differentials, this system exerts the following effects.

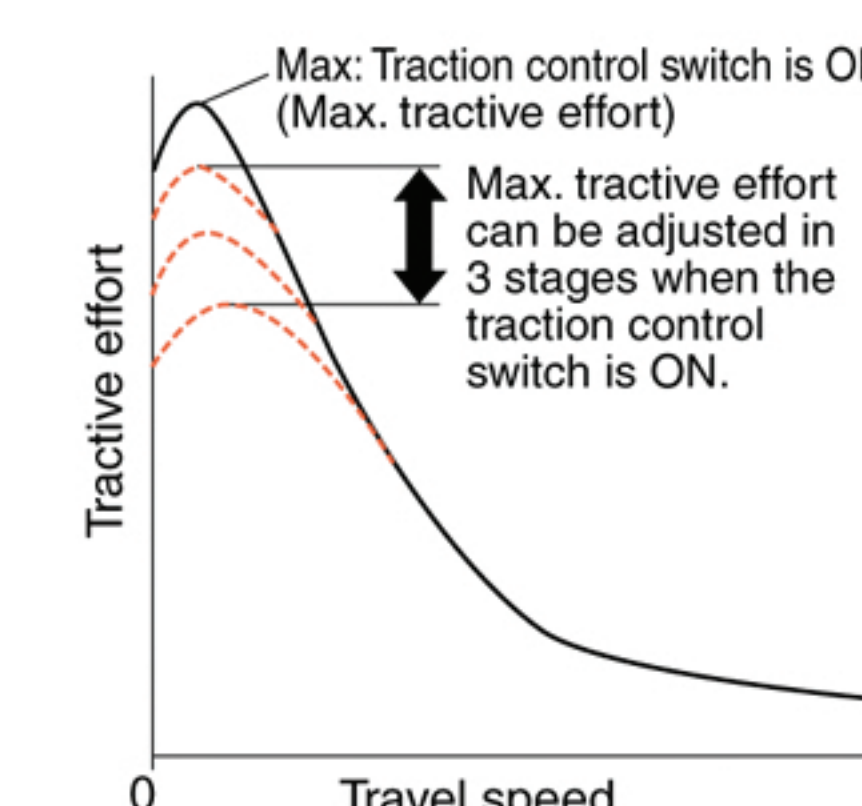

- Facilitates operation on soft ground where the tires of the machine are apt to slip.
- Eliminates excessive bucket penetration and reduces tire slippage during stockpile loading to improve the work efficiency.
- Reduces tire slippage to extend the life of tires.

Furthermore, the maximum tractive effort can be adjusted in three stages (one stage for conventional machines) when the traction control switch is ON. This allows the operator to select the optimum tractive effort for diversified road conditions.

S-mode

Setting the switch to S-mode allows the machine to get the optimum driving force for operations on slippery road surfaces, like snow-removal on snow surface, resulting in reduced tire slippage and facilitation of the operation. Unexpected tire slippage on slippery road surface is suppressed by controlling the engine speed and HST motor when traveling at a low speed. (S-mode is effective only in forward traveling.)

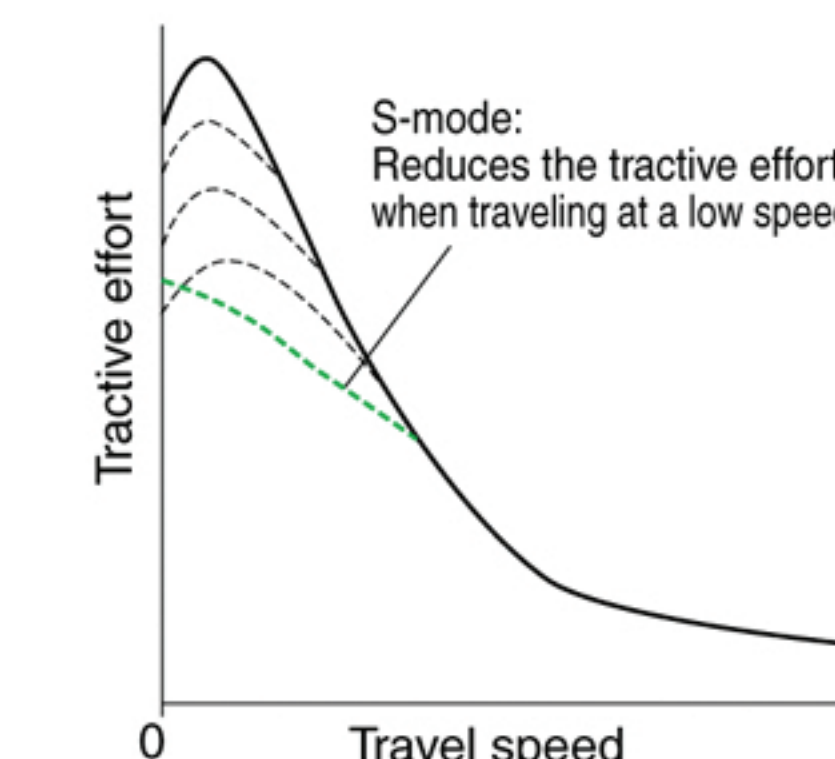

Max. Traction Switch

Max. traction switch is located on the work equipment control lever. When traction control switch is at ON position or S-mode is selected, pushing this switch cancels the setting of the traction control temporarily and increases the tractive effort to its 100% value. Then pushing the max. traction switch again or operating the F/R lever returns the tractive effort to the set value automatically. This switch is useful for operations such as piling up work where large tractive effort is required temporarily.

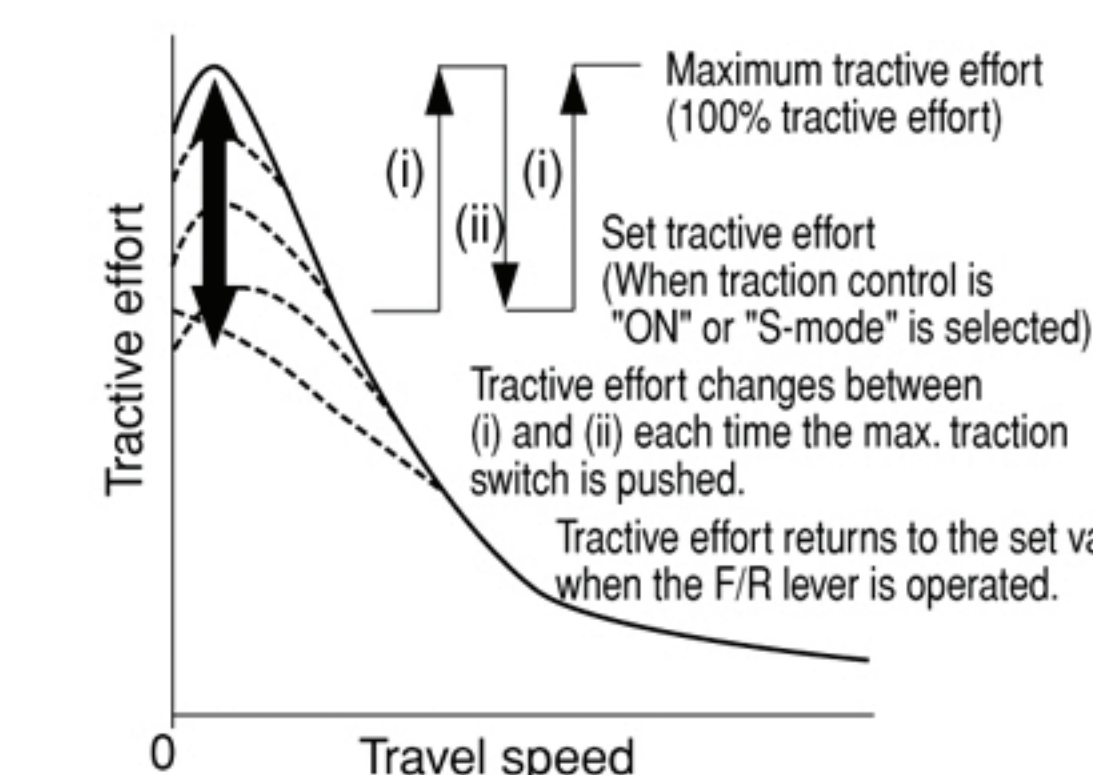

Accelerator Pedal Sensitive HST Control

Finely-tuned HST control according to the accelerator pedal angle reduces shocks and allows smoother traveling and better energy-saving operation.



Maximum Dumping Clearance and Reach

The long lift arms provide high dumping clearances and maximum dumping reach. The operator can even level loads on the body of a dump truck easily and efficiently.

Dumping Clearance: 2800 mm 9'2"
Dumping Reach: 1130 mm 3'8"
 (2.7 m³ 3.5 yd³ bucket with B.O.C.)

INCREASED RELIABILITY

Komatsu Components

Komatsu manufactures the engine, transfer case, axles and hydraulic components on this wheel loader.

Komatsu loaders are manufactured with an integrated production system under a strict quality control system.

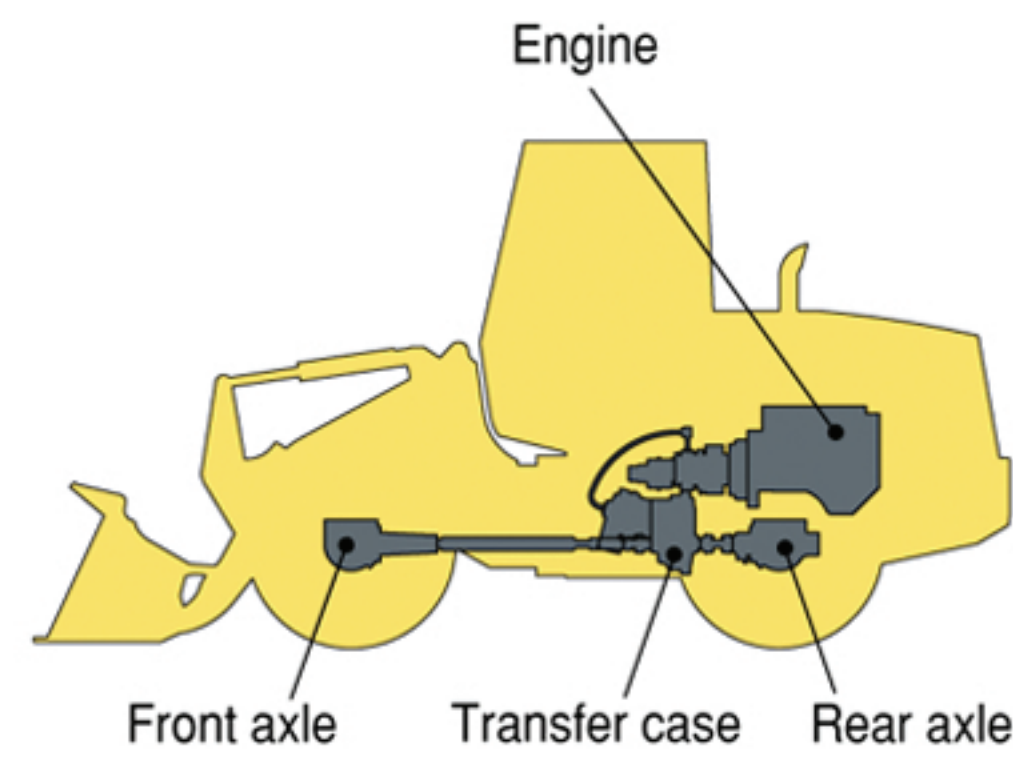

Wet multi-disc brakes and fully hydraulic braking system

mean lower maintenance costs and higher reliability. Wet disc brakes are fully sealed. Contaminants are kept out, reducing wear and resulting maintenance. Brakes require no adjustments for wear, meaning even lower maintenance. The parking brake is also an adjustment-free, wet multi-disc for high reliability and long life.

Added reliability is designed into the braking system by the use of two independent hydraulic circuits, providing hydraulic backup should one of the circuits fail.

Fully hydraulic brakes mean no air system to bleed, and no condensation of water in the system that can lead to contamination, corrosion, and freezing.

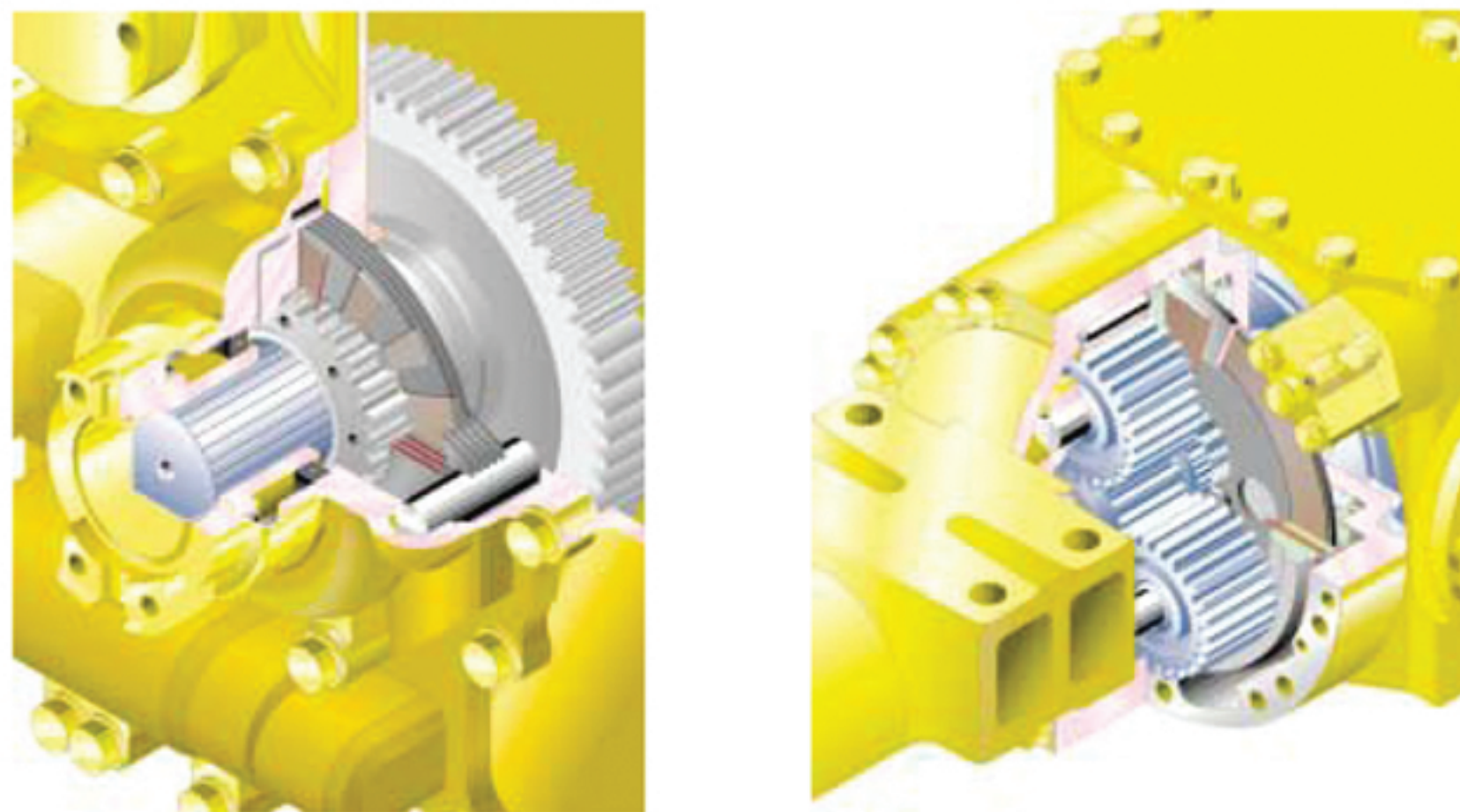

Overrun Prevention System

When the machine descends a slope of six degrees or less, maximum travel speed is automatically restricted to approximately **38 km/h 23 MPH**, for protection against damage of power train components and brakes by sensing the travel speed and controlling the discharge amount of the HST pump and motor. When the machine descends a steep slope and the travel speed reaches **36 km/h 22 MPH**, the caution lamp lights up to inform the operator to reduce the travel speed.

Note: When the machine descends a steep slope, the use of the service brake is necessary to limit travel speed.

High-rigidity Frames and Loader Linkage

The front and rear frames and the loader linkage have got more torsional rigidity to provide resistance increased to stresses. Frame and loader linkage are designed to accommodate actual working loads, and simulated computer testing proves its strength.

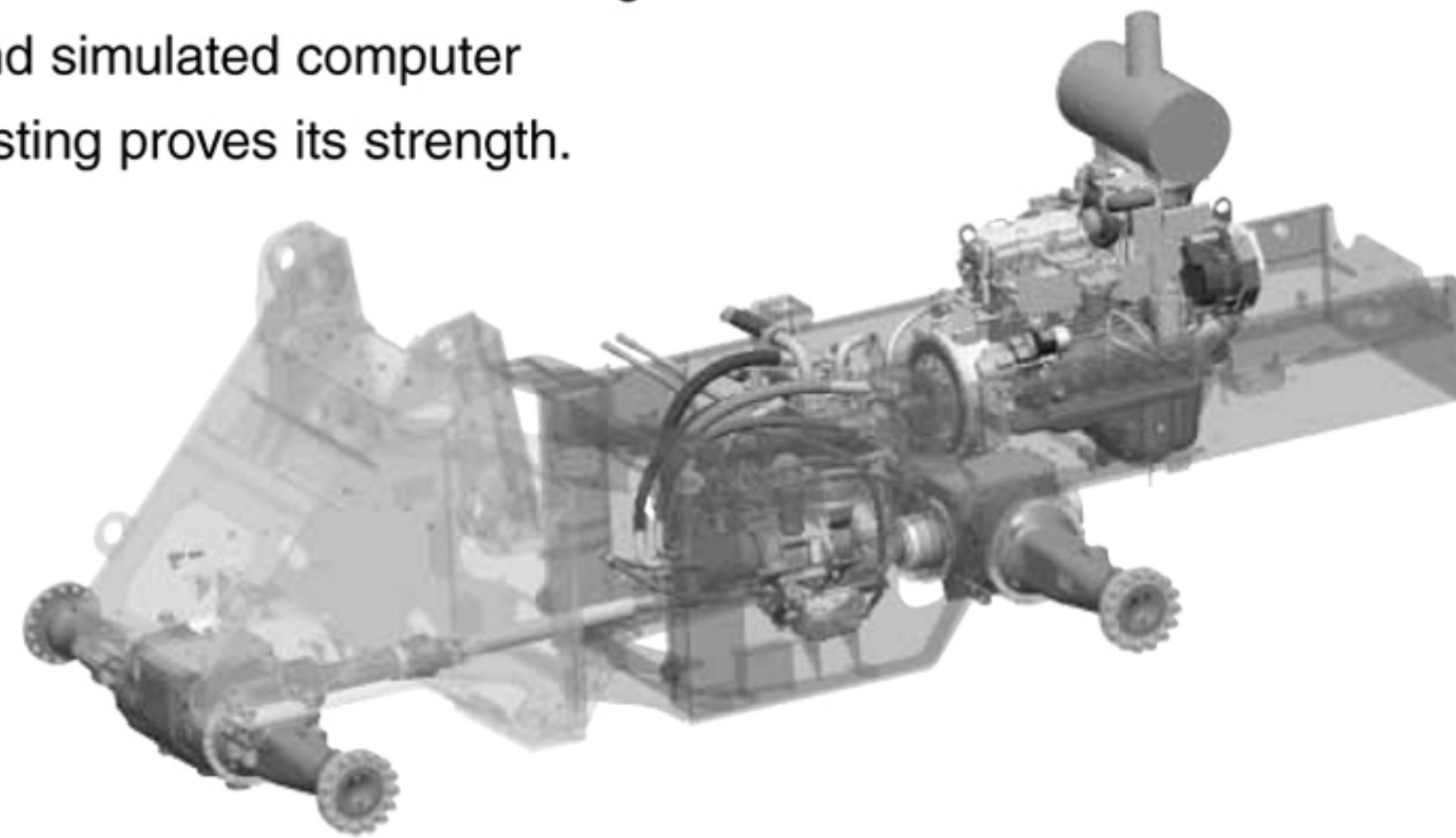

Flat Face-to-Face O-Ring Seals

Flat face-to-face O-ring seals are used to securely seal hydraulic hose connections.

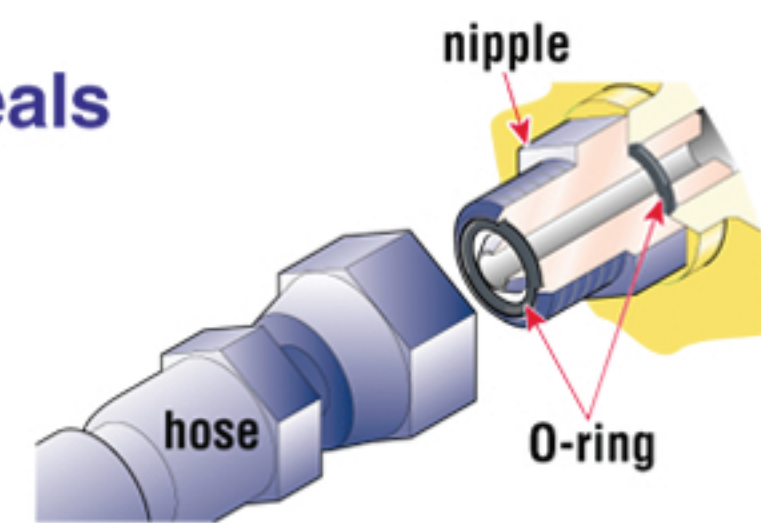

Cathion Electrodeposition Primer Paint/ Powder Coating Final Paint

Cathion electrodeposition paint is applied as a primer paint and powder coating is applied as topcoat to the exterior metal sheet parts. Some external parts are made of plastic providing long life and high impact resistance.

Sealed DT Connectors

Main harnesses and controller connectors are equipped with sealed DT connectors providing high reliability, water resistance and dust resistance.



EASY MAINTENANCE



Photo may include optional equipment.

EMMS (Equipment Management Monitoring System)

Monitor is mounted in front of the operator for easy view, allowing the operator to easily check gauges and warning lights.



A specially designed two-spoke steering wheel allows the operator to easily see the instrument panel.

Maintenance Control and Troubleshooting Functions

- **Action code display function:** If an abnormality occurs, the monitor displays action details on the character display at the center bottom of the monitor.
- **Monitor function:** Controller monitors engine oil pressure, coolant temperature, air cleaner clogging, etc. If the controller finds abnormalities, the error is displayed on the LCD.
- **Replacement time notice function:** Monitor informs replacement time of oil and filters on the LCD when replacement intervals are reached.
- **Trouble data memory function:** Monitor stores abnormalities for effective troubleshooting.

Gull-wing Type Engine Side Doors Open Wide

The operator can open and close each gull-wing type engine side door easily with the assistance of a gas spring to perform daily service checks from the ground.



Ease of Radiator Cleaning

If the machine is operating in adverse conditions, the operator can reverse the hydraulic cooling fan from inside the cab by turning on a switch on the control panel.

Automatic Reversible Fan (option)

The engine fan is driven hydraulically. It can be operated in reverse automatically. When switch is automatic position. The fan revolves in reverse for 2 minutes every 2 hours intermittently. (Default setting)

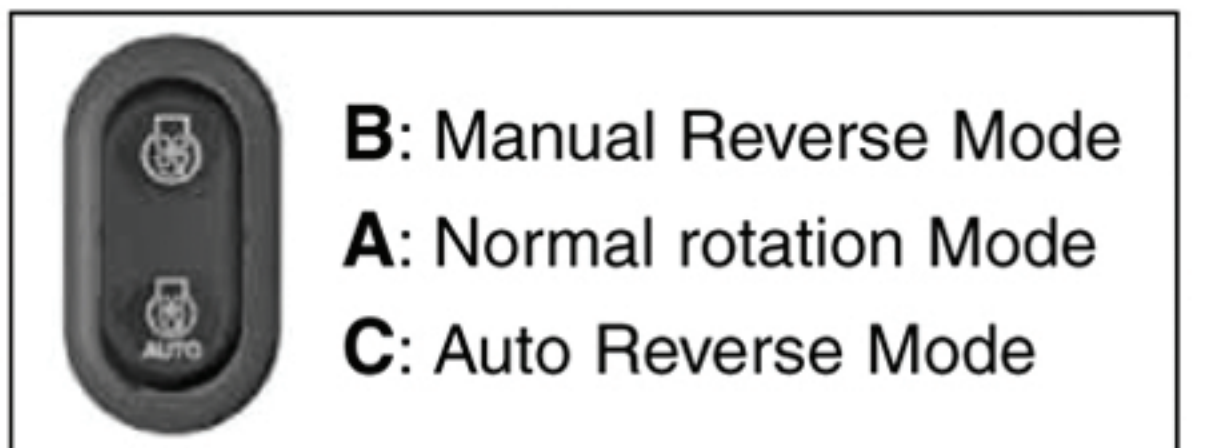

OPERATOR ENVIRONMENT

Easy Operation

Electronically Controlled Directional Lever

The operator can change direction with a touch of his fingers without removing his hand from the steering wheel. Solid state electronics makes this possible.



Tilttable Steering Column

The operator can tilt the steering column to provide a comfortable working position.



Easy-to-operate Loader Control Mono-lever

A new mono-lever using PPC (Proportional Pressure Control) allows the operator to easily operate the work equipment, to reduce operator fatigue and to increase controllability.

The adjustable wrist rest provides the operator with a variety of comfortable operating positions.



Right-side control panel

The operator can select the speed range, maximum travel speed in 1st, tractive effort.

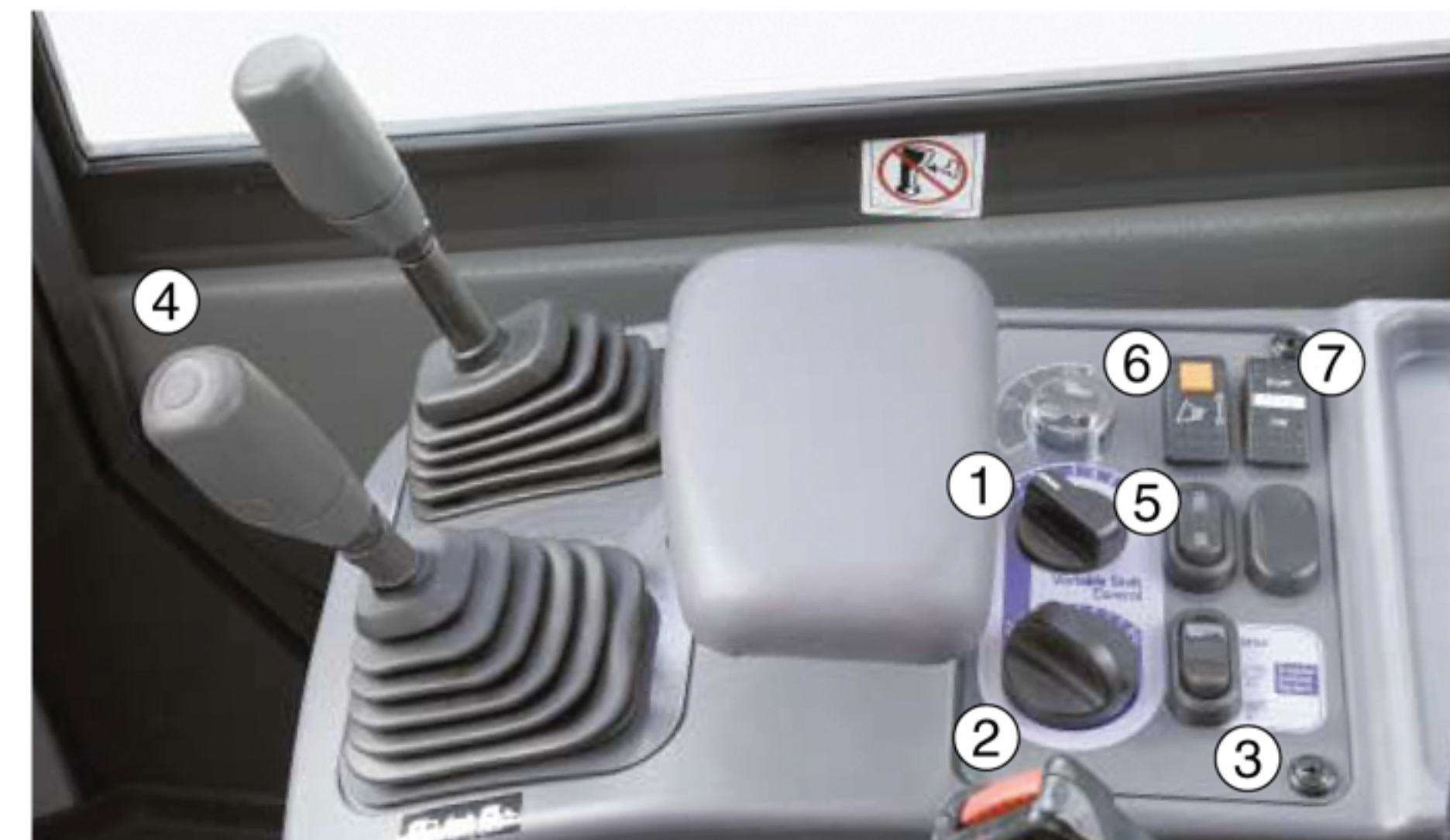

- 1: Speed range selector switch
- 2: Variable shift switch
- 3: Traction control switch
- 4: Max. traction switch
- 5: Fan reverse switch
- 6: Quick coupler lock switch
- 7: 2 mode bucket leveler switch

Comfortable Operation

Low-noise Design

Noise at operator's ear noise level : 70 dB(A)
Dynamic noise level (outside): 107 dB(A)

The large cab is mounted with Komatsu's unique ROPS/FOPS viscous mounts. The low-noise engine, hydraulically driven fan, and hydraulic pumps are mounted with rubber cushions, and the cab sealing is improved to provide a quiet, low-vibration, pressurized, and comfortable operating environment.

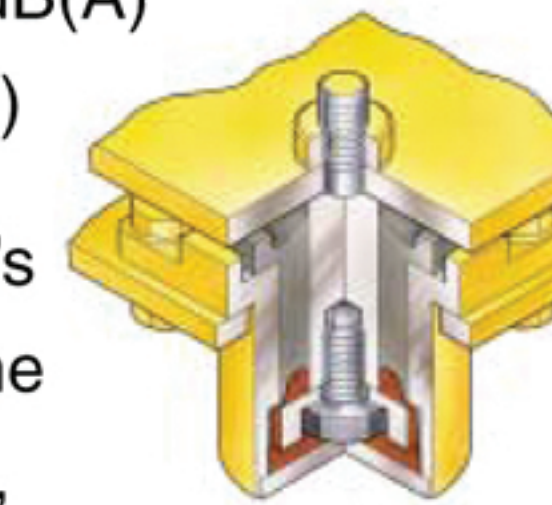

Pillar-less Large Cab

A wide pillar-less flat glass provides excellent front visibility. The wiper arm covers a large area to provide great visibility even on rainy days.

The large cab area provides maximum space for the operator. The front mounted air conditioner was introduced to increase seat reclining and backward slide adjustment.

Rear-hinged Full Open Cab Doors

Entry and exit into the new Komatsu cab starts with sloped staircase type steps and large diameter handrails for added comfort. The large cab doors are rear-hinged to open fully offering easy entry/exit and will not hamper visibility when operating the machine with the doors latched open.



Photo may include optional equipment.



SPECIFICATIONS



ENGINE

ModelKomatsu SAA6D107E-1
 TypeWater-cooled, 4-cycle
 AspirationTurbocharged, aftercooled
 Number of cylinders6
 Bore x stroke107 mm x 124 mm 4.21" x 4.88"
 Piston displacement6.69 ltr 408 in³
 GovernorAll-speed, electronic
 Horsepower
 SAE J1995Gross 127.3 kW 171 HP
 ISO 9249/SAE J1349*Net 125 kW 167 HP
 Rated rpm2000 rpm
 Fan drive method for radiator coolingHydraulic
 Fuel systemDirect injection
 Lubrication system:
 MethodGear pump, force-lubrication
 FilterFull-flow type
 Air cleanerDry type with double elements and dust evacuator, plus dust indicator

*Net horsepower at the maximum speed of radiator cooling fan is 117 kW 156 HP.



TRANSMISSION

Transmission:
 TypeHydrostatic, 1 pump, 2 motors with speed range select
 Travel speed: km/h mph
 Measured with 20.5-25 tires

| | 1st | 2nd | 3rd | 4th |
|--------------|------------|------|------|------|
| Both Forward | 4.0 - 13.0 | 13.0 | 18.7 | 38.0 |
| and Reverse | 2.5 - 8.1 | 8.1 | 11.6 | 23.6 |



AXLES AND FINAL DRIVES

Drive systemFour-wheel drive
 FrontFixed, semi-floating
 RearCenter-pin support, semi-floating, 24° total oscillation
 Reduction gearSpiral bevel gear
 Differential gearTorque proportioning
 Final reduction gearPlanetary gear, single reduction



BRAKES

Service brakesHydraulically actuated, wet disc brakes actuate on four wheels
 Parking brakeWet, multi-disc brake on transfer output shaft
 Emergency brakeParking brake is commonly used



STEERING SYSTEM

TypeFull-hydraulic power steering
 Steering angle38.5° each direction (40° end stop)
 Minimum turning radius at the center of outside tire5380 mm 17'8"



HYDRAULIC SYSTEM

Steering system:
 Hydraulic pumpGear type pump
 Capacity172 ltr/min 45.4 U.S. gal/min at rated rpm
 Relief valve setting20.6 MPa 210 kgf/cm² 2,990 psi
 Hydraulic cylinders:
 TypeDouble-acting, piston type
 Number of cylinders2
 Bore x stroke70 mm x 453 mm 2.8" x 17.8"

Loader control:
 Hydraulic pumpGear type pump
 Capacity61 ltr/min 16.1 U.S. gal/min
 Relief valve setting20.6 MPa 210 kgf/cm² 3,000 psi
 Hydraulic cylinders:
 TypeDouble-acting, piston type
 Number of cylinders—bore x stroke:
 Boom cylinder2- 140 mm x 729 mm 5.5" x 28.7"
 Bucket cylinder1- 180 mm x 558 mm 7.1" x 22.0"
 Control valve3-spool type
 Control positions:
 BoomRaise, hold, lower, and float
 BucketTilt-back, hold, and dump
 Hydraulic cycle time (rated load in bucket)
 Raise5.6 sec
 Dump1.9 sec
 Lower (Empty)3.3 sec



SERVICE REFILL CAPACITIES

Cooling system25 ltr 6.6 U.S. gal
 Fuel tank245 ltr 64.7 U.S. gal
 Engine23 ltr 6.1 U.S. gal
 Hydraulic system89 ltr 23.5 U.S. gal
 Axle (each front and rear)24 ltr 6.3 U.S. gal
 Torque converter and transmission6.5 ltr 1.7 U.S. gal



BUCKET SELECTION GUIDE

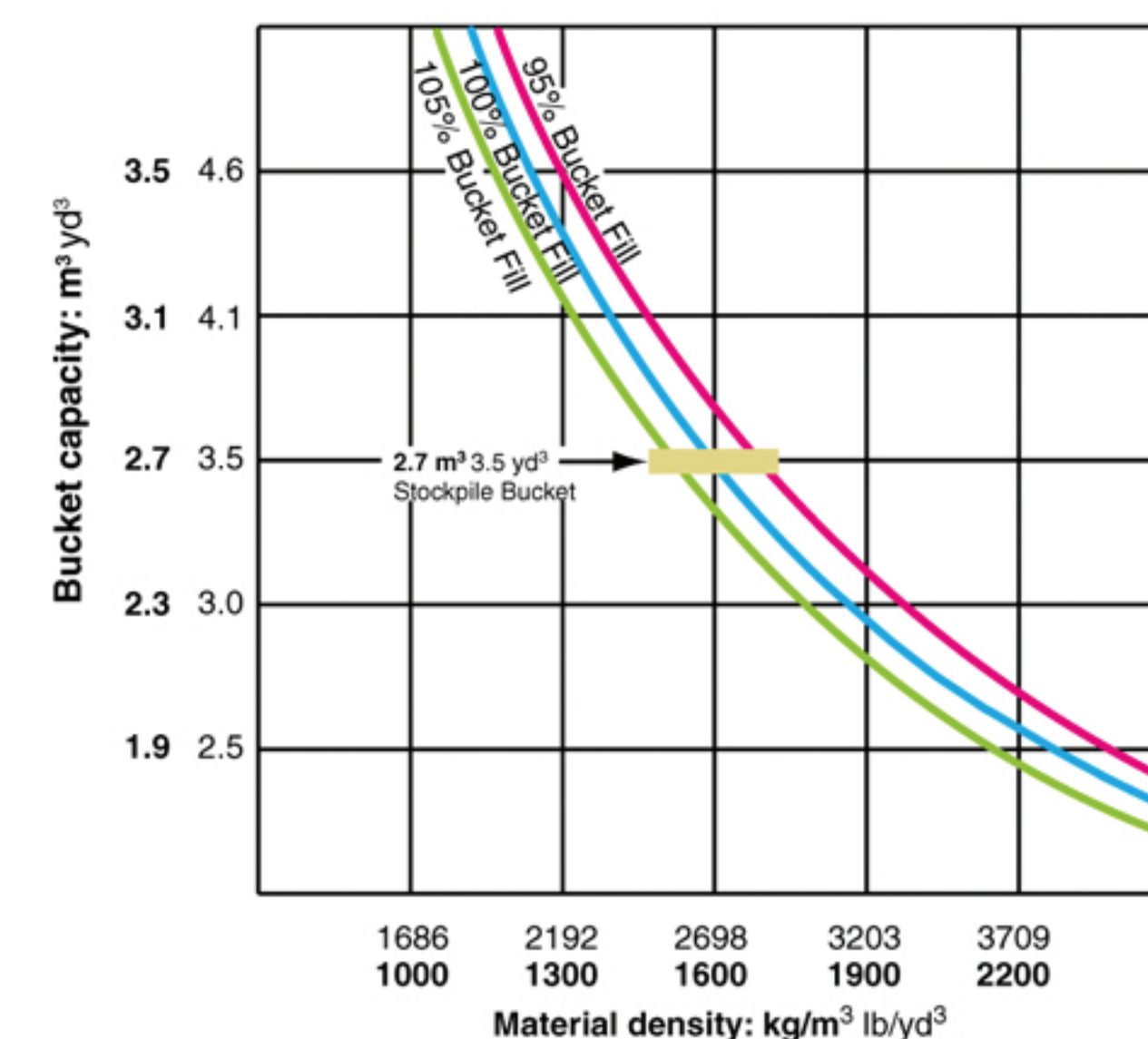

DIMENSIONS

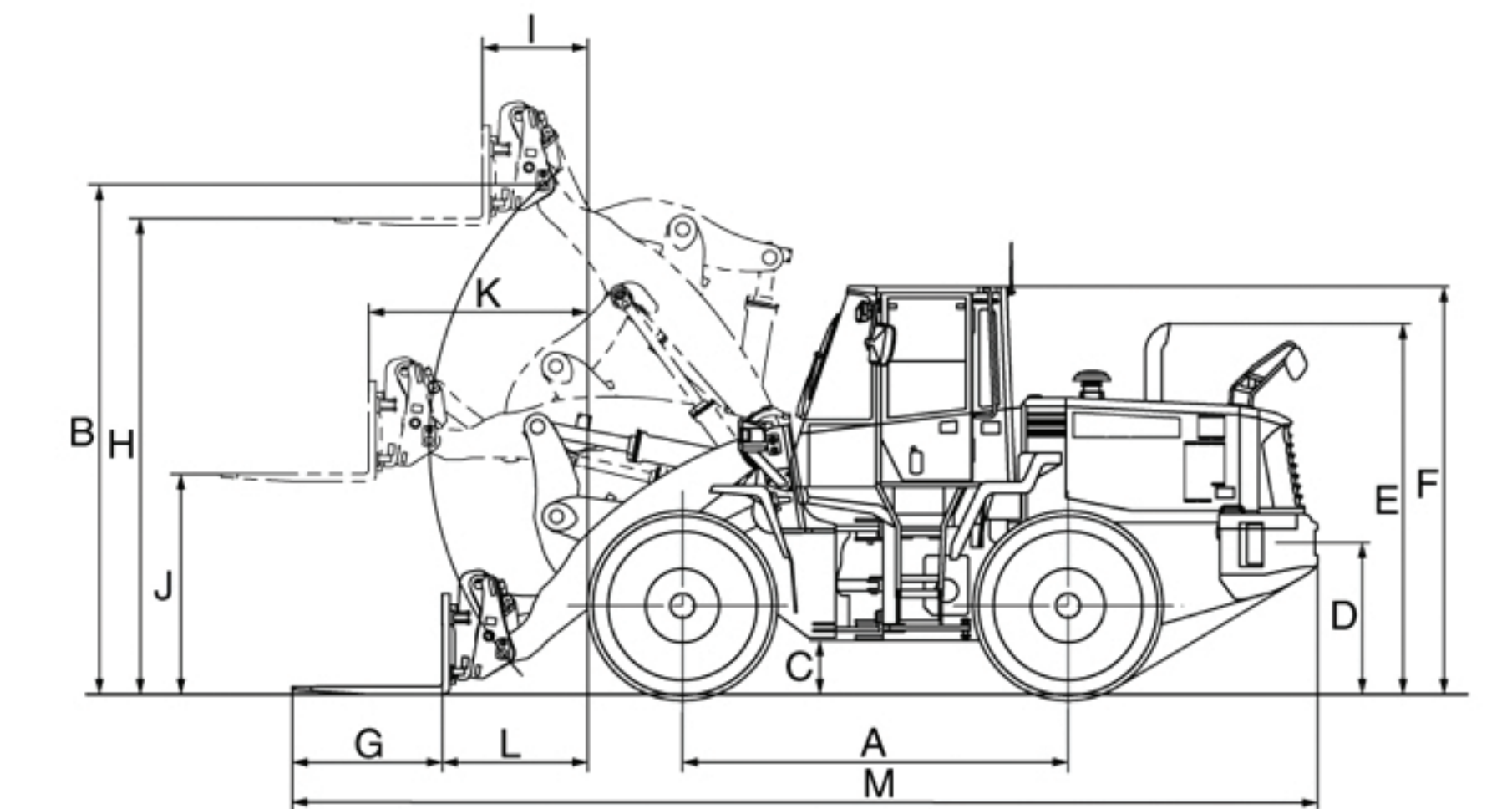
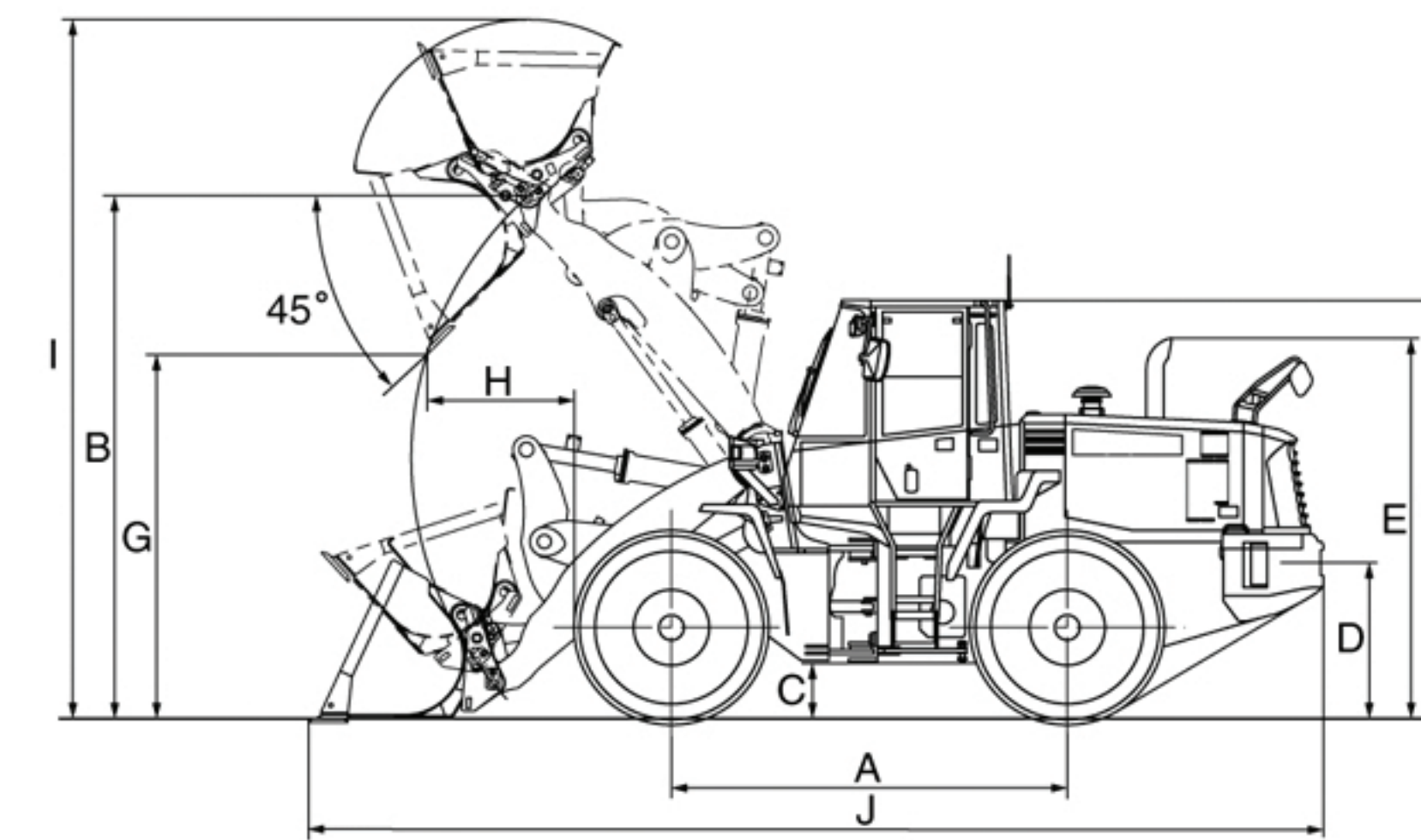

Standard tire20.5-25-12PR(L2)
 Tread2050 mm 6'9"
 Wide over tires2590 mm 8'6"
 A Wheelbase3030 mm 9'11"
 B Hinge pin height, maximum height4005 mm 13'2"

C Ground clearance425 mm 1'5"
 D Hitch height1095 mm 3'7"
 E Overall height, top of stack2915 mm 9'7"
 F Overall height, ROPS cab3200 mm 10'6"

Bucket

| | Bucket type with bolt-on cutting edge | | Light Material | |
|---|---------------------------------------|---------------------|--------------------|---------------------|
| | Heaped | Struck | 2.7 m ³ | 3.5 yd ³ |
| Bucket Capacity | 2.7 m ³ | 3.5 yd ³ | 2.3 m ³ | 3.0 yd ³ |
| Bucket Width | 2740 mm | 9'0" | | |
| Static Tipping Load | Straight | 10410 kg | 22,950 lb | |
| | Full Turn (40°) | 9160 kg | 20,190 lb | |
| Operating Weight | | 15280 kg | 33,690 lb | |
| QC-Bucket Weight | | 1140 kg | 2,510 lb | |
| G Dumping Clearance, maximum height and 45° dump angle* | | 2800 mm | 9'2" | |
| H Reach at 2130 mm 7' and 45° dump angle* | | 1670 mm | 5'6" | |
| H Reach at maximum height and 45° dump angle* | | 1130 mm | 3'8" | |
| I Reach with boom/bucket level* | | 2655 mm | 8'9" | |
| I Operating Height, fully raised | | 5355 mm | 17'7" | |
| J Overall Length, bucket on ground | | 7770 mm | 25'6" | |
| Digging Depth | 0° | 130 mm | 5.1" | |
| | 10° | 370 mm | 1'3" | |
| Breakout Force | | 14410 kg | 31,770 lb | |

*At the end of B.O.C.

All dimensions, weights, and performance values based on SAE J732c and J742b standards. Static tipping load and operating weight shown include lubricant, coolant, full fuel tank, ROPS cab and operator. Machine stability and operating weight affected by tire size and attachments.

Fork

| | Static tipping load – boom level | | Fork level, 610 mm 24" load center | |
|---|----------------------------------|-----------------|------------------------------------|-----------|
| | Straight | Full turn (40°) | 8235 kg | 18,150 lb |
| Operating weight | | | 14695 kg | 32,400 lb |
| G Fork tine length | | | 1220 mm | 4'0" |
| H Ground to top of tine at maximum lift | | | 3810 mm | 12'6" |
| I Reach at maximum lift | | | 835 mm | 2'9" |
| J Ground to top of Tine – boom and tine level | | | 1795 mm | 5'11" |
| K Reach – boom and tine level | | | 1730 mm | 5'8" |
| L Reach – tine level on ground | | | 1100 mm | 3'7" |
| M Overall Length – tine level on ground | | | 8035 mm | 26'4" |
| Operating load | | | 3525 kg | 7,770 lb |

Operating load per SAE J1197 (Feb. 1991), 50% of static tipping load.

Static tipping load and operating weight shown include lubricant, coolant, full fuel tank, ROPS cab and operator. Machine stability and operating weight affected by tire size and attachments.

Weight Changes

| | Change in Operating Weight | | Change in Tipping Load | | Width Over Tires | Ground Clearance | Change in Vertical Dimensions | |
|--------------------------------------|----------------------------|---------|------------------------|-----------|------------------|------------------|-------------------------------|------|
| | 165 kg | 364 lb | Straight | Full Turn | | | 0 mm | 0" |
| 20.5/25-12PR (L3) | 165 kg | 364 lb | 105 kg | 231 lb | 2590 mm | 8'6" | 425 mm | 1'5" |
| Install ROPS canopy (instead of cab) | -290 kg | -639 lb | -135 kg | -298 lb | | | | |



STANDARD EQUIPMENT

- 3-spool valve for boom and bucket controls
- Additional counterweight
- Air conditioner
- Alternator, 60 A
- Auto shift transmission with mode select system
- Back-up alarm
- Back-up lamp
- Batteries, **110 Ah/2 x 12 V**
- Bucket positioner
- Counterweight
- Directional signal
- Engine, Komatsu SAA6D107E-1 diesel
- Engine shut-off system, electric
- Floor mat
- Fuel prefilter with water separator
- Hydraulic-driven fan with reverse rotation
- Lift cylinders and bucket cylinder
- Loader linkage with PZ lift arm
- Main monitor panel with EMMS (Equipment Management Monitoring System)
- PPC fingertip control, mono lever +1
- Quick coupler
- Radiator mask, lattice type
- Rear defroster (electric)
- Rear view mirror
- Rear window washer and wiper
- ROPS/FOPS cab
- Seat, rigid type with reclining
- Seat belt
- Service brakes, wet disc type
- Starting motor, **4.5 kW/24 V**
- Steering wheel, tiltable
- Sun visor
- Tires (20.5-25-12PR, L2 tubeless) and rims
- Transmission, 4 forward and 4 reverse
- Bucket, stockpile, for use with coupler with B.O.C. **2.7 m³ 3.5 yd³**



Quick coupler



OPTIONAL EQUIPMENT

- 3-lever loader control
- AM/FM radio
- AM/FM stereo radio cassette
- Automatic reversible fan
- Boom kick-out
- Bucket teeth (bolt-on type)
- Bucket teeth (tip type)
- Cutting edge (bolt-on type)
- Deluxe suspension seat
- ECSS (Electronically Controlled Suspension System)
- Emergency steering (SAE)
- Engine pre-cleaner with extension
- Fire extinguisher
- Front fenders
- Limited slip differential (F&R)
- Log grapple
- Rear full fender
- Tool kit
- Vandalism protection kit
- Pallet forks for use with coupler, **1220 mm 4'0"**

www.Komatsu.com

Printed in Japan 200811 IP.SIN (20)

KOMATSU[®]

CEN00319-01

Materials and specifications are subject to change without notice
KOMATSU is a trademark of Komatsu Ltd. Japan