

KOMATSU®

PC240LC-11

EPA Tier 4 Final Engine

Australia & New Zealand Specifications

HYDRAULIC EXCAVATOR



Photos may include optional equipment.

NET HORSEPOWER

132 kW / 177 HP @ 2000 rpm

OPERATING WEIGHT

25,380 – 26,240 kg

BUCKET CAPACITY

0.43 – 1.08 m³

PC240LC

WALK-AROUND

PC240LC-11



Photos may include optional equipment.

NET HORSEPOWER
132 kW / 177 HP @ 2000 rpm

OPERATING WEIGHT
25,380 – 26,240 kg

BUCKET CAPACITY
0.43 – 1.08 m³

PERFORMANCE & FUEL ECONOMY

New engine and hydraulic pump control technology improves operational efficiency and lowers fuel consumption up to 9%.

Komatsu Harmony

All major components are designed and manufactured by Komatsu. A fully integrated design produces an efficient, reliable system.

A powerful **Komatsu SAA6D107E-3 engine** provides a net output of 132 kW 177 HP. This engine is EPA Tier 4 Final emissions certified.

Komatsu Variable Geometry Turbocharger (KVG) uses a hydraulic actuator to provide optimum air flow under all speed and load conditions.

Komatsu Diesel Particulate Filter (KDPF) and Selective Catalytic Reduction (SCR) system reduce particulate matter and NOx while providing automatic regeneration that does not interfere with daily operation.

Large displacement high efficiency pumps provide high flow output at low engine speed, improving efficiency.

Komatsu's Closed-centre Load Sensing System (CLSS) provides quick response and smooth operation to maximise productivity.

Enhanced working modes are designed to match engine speed, pump delivery, and system pressure to the application.

The **KOMTRAX®** telematics system is standard on Komatsu equipment with no subscription fees. Using the latest wireless technology, **KOMTRAX®** transmits valuable information such as location, utilisation, and maintenance records to a PC or smartphone app. Custom machine reports are provided for identifying machine efficiency and operating trends. **KOMTRAX®** also provides advanced machine troubleshooting capabilities by continuously monitoring machine health.

Large LCD colour monitor panel:

- 7" high resolution screen
- Provides "Ecology Guidance" for fuel efficient operation
- Enhanced attachment control

Rearview monitoring system (standard)

Equipment Management Monitoring System (EMMS) continuously monitors machine operation and vital systems to identify machine issues and assist with troubleshooting.



Enhanced working environment

- High back, heated air suspension operator seat with new adjustable arm rests
- Integrated ROPS cab design (ISO 12117-2)
- Cab meets ISO Level 1 Operator Protective Guard (OPG) top guard (ISO 10262)
- Aux jack and (2) 12V power outlets

Komatsu designed and manufactured components

Wide access service doors provide easy access for ground level maintenance.

Handrails (standard) on both sides provide more convenient access to the upper structure.

Lockable single pole battery isolation switch allows a technician to disconnect the power supply before servicing the machine.

Komatsu Auto Idle Shutdown helps reduce idle time and reduce operating costs.

Operator Identification System can track machine operation for up to 100 operators.

PERFORMANCE FEATURES

KOMATSU NEW ENGINE TECHNOLOGIES

New Tier 4 Final Engine

The Komatsu SAA6D107E-3 engine is EPA Tier 4 Final emissions certified and provides exceptional performance while reducing fuel consumption. Based on Komatsu proprietary technologies developed over many years, this new diesel engine reduces particulate matter (PM) and nitrogen oxides (NOx) by 90% when compared to Tier 3 levels. Through the in-house development and production of engines, electronics, and hydraulic components, Komatsu has achieved great advancements in technology, providing high levels of performance and efficiency in virtually all applications.

Technologies Applied to New Engine

Heavy-duty aftertreatment system

This new system combines a Komatsu Diesel Particulate Filter (KDPF) and Selective Catalytic Reduction (SCR). The SCR NOx reduction system injects the correct amount of Diesel Exhaust Fluid (DEF) at the proper rate, thereby decomposing NOx into non-toxic water vapour (H₂O) and nitrogen gas (N₂).

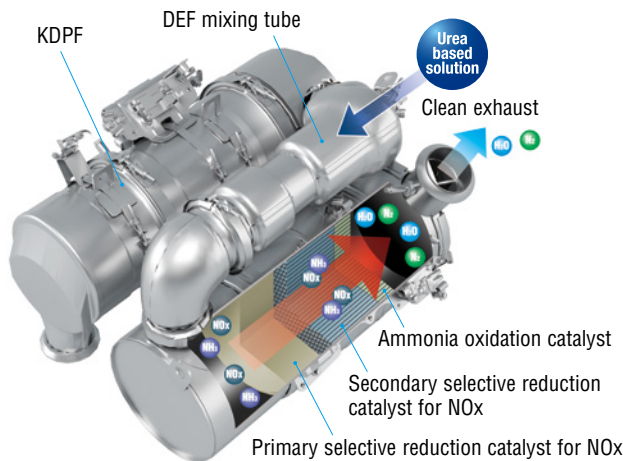

Heavy-duty cooled Exhaust Gas Recirculation (EGR) system

The system recirculates a portion of exhaust gas into the air intake and lowers combustion temperatures to reduce NOx emissions. Furthermore, while EGR gas flow is increased, by incorporating a high-efficiency and compactly designed cooling system, the system achieves a dynamic reduction of NOx, while helping reduce fuel consumption.

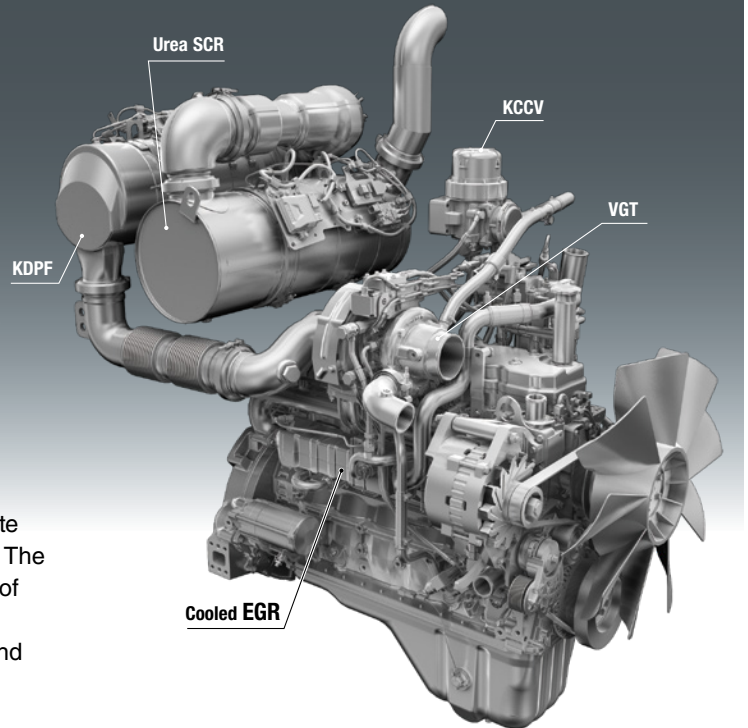
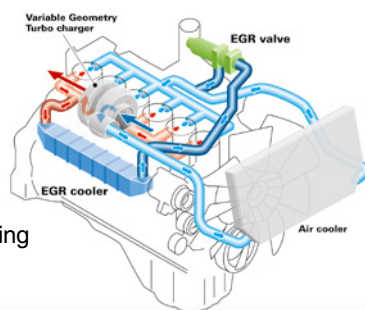

Advanced Electronic Control System

The electronic control system performs high-speed processing of all signals from sensors installed in the vehicle providing total control of equipment in all conditions of use. Engine condition information is displayed via an on-board network to the monitor inside the cab, providing necessary information to the operator. Additionally, managing the information via KOMTRAX helps customers keep up with required maintenance.

Komatsu Variable Geometry Turbocharger (KVTG) system

The VGT system features proven Komatsu designed hydraulic technology for variable control of air-flow and supplies optimal air according to load conditions. The upgraded version provides better exhaust temperature management.

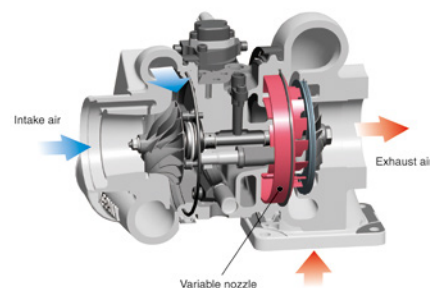

PG240LG-11

Komatsu Auto Idle Shutdown

Komatsu auto idle shutdown automatically shuts the engine down after idling for a set period of time to reduce unnecessary fuel consumption and exhaust emissions.



Heavy-Duty High-Pressure Common Rail (HPCR) Fuel Injection System

The system is designed to achieve an optimal injection of high-pressure fuel by means of computerised control, providing close to complete combustion to reduce PM emissions. While this technology is already used in current engines, the new system uses high pressure injection, thereby reducing PM emissions over the entire range of engine operating conditions. The Tier 4 Final engine has advanced fuel injection timing for reduced soot levels.

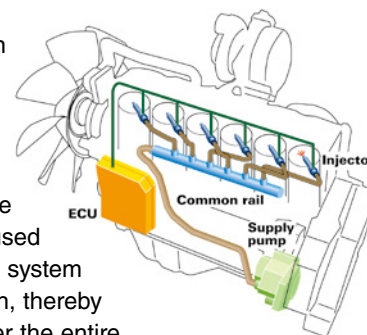

PERFORMANCE FEATURES

Reduced Fuel Consumption

The PC240LC-11's new tier 4 final engine along with enhancements in the hydraulic system considerably decreases fuel consumption.

Fuel Consumption

Reduced by 9%

(vs PC220LC-8M0 Based on typical work pattern collected via KOMTRAX)

This fuel consumption data is the result compared actual measured value using the prototype machine. Actual fuel savings may vary depending on application and operating conditions.

Increased Work Efficiency

Powerful digging force

Functional digging force can be increased with use of the one-touch Power Max. function (up to 8.5 seconds of operation).

Maximum arm crowd force (ISO)

121 kN(12.3t) ➔ **129 kN(13.2t) 7% UP**
(with Power Max.)

Maximum bucket digging force (ISO)

159 kN(16.2t) ➔ **172 kN(17.5t) 8% UP**
(with Power Max.)

Measured with Power Max. function, 3000 mm arm and ISO rating



PC240LC-11

Efficient Hydraulic System

The PC240LC-11 uses a Closed-centre Load Sensing System (CLSS) that improves fuel efficiency and provides quick response to the operator's demands. The PC240LC-11 also incorporates new technology to enhance the engine and hydraulic pump control. This total control system matches the engine and hydraulics at the most efficient point under any load condition. There have also been improvements in the main valve and hydraulic circuit to reduce hydraulic loss, resulting in higher efficiency and lower fuel consumption.



Large Displacement High Efficiency Pump

Large displacement hydraulic implement pumps provide high flow output at lower engine RPM as well as operation at the most efficient engine speed.

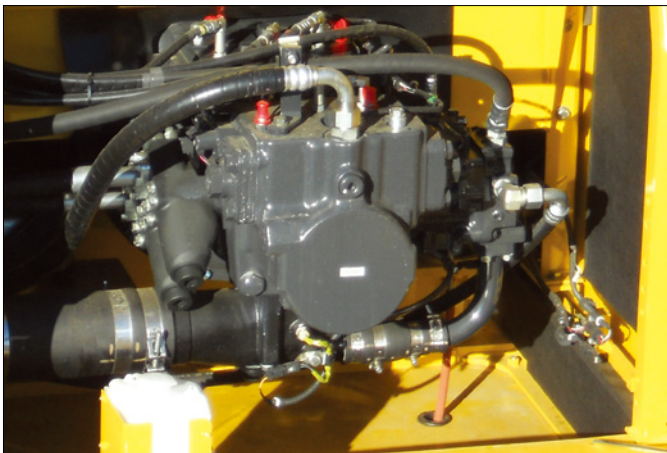

Working Mode Selection

The PC240LC-11 excavator is equipped with six working modes (P, E, L, B, ATT/P and ATT/E). Power Mode provides improved hydraulic power and faster cycle times for improved performance in demanding applications. Each mode is designed to match engine speed, pump flow, and system pressure to the application. The PC240LC-11 features an attachment mode (ATT/E) that allows operators to run attachments while in Economy mode.

Working Mode	Application	Advantage
P	Power Mode	•Maximum production, power & multifunction
E	Economy Mode	•Good cycle times with reduced fuel consumption
L	Lifting Mode/ Fine Control	•Increased lifting power & fine control
B	Breaker Mode	•One way flow for hydraulic breaker operation
ATT/P	Attachment Power Mode	•Two way flow with maximum power
ATT/E	Attachment Economy Mode	•Two way flow with most efficient fuel economy

P Performance priority
P mode

E Fuel savings priority
E mode

L Lifting operation
L mode

B One way flow breaker operation
B mode

ATT/P Two way flow attachment – Power
ATT/P mode

ATT/E Two way flow attachment – Economy
ATT/E mode

High Rigidity Work Equipment

Booms and arms are constructed with thick plates of high tensile strength steel. In addition, these structures are designed with large cross sectional areas and large one piece steel castings in the boom foot, the boom tip, and the arm tip. The result is work equipment that exhibits long term durability and high resistance to bending and torsional stress. A standard HD boom design provides increased strength and reliability.



WORKING ENVIRONMENT

PC240LC-11





Comfortable Working Space

Wide spacious cab

The wide spacious cab includes a heated air suspension seat with reclining backrest. The seat height and position are easily adjusted using a pull-up lever. The armrest position is easily adjusted together with the console. Reclining the seat further enables it to be fully laid back with the headrest attached.

Arm rest with simple height adjustment function

A knob and plunger on the armrests allows easy height adjustment without the use of tools.



Low vibration with cab damper mounting

Automatic climate control

Pressurised cab

Auxiliary input jack

Connecting a regular audio device to the auxiliary jack allows the operator to hear the sound from the stereo speakers installed in the cab.



Standard Equipment

Sliding window glass (left side)



AM/FM stereo radio



Remote intermittent wiper with windshield washer

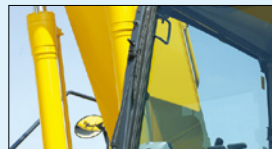

Emergency stop & level indicator



ISO level 2 OPG



Magazine box & cup holder



Defroster (conforms to the ISO standard)



One-touch storable front window lower glass

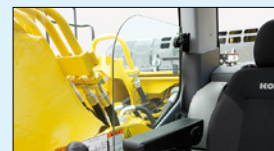

WORKING ENVIRONMENT

PC240LC-11

LARGE HIGH RESOLUTION LCD MONITOR



New Monitor Panel Interface Design

An updated large high resolution LCD colour monitor enables accurate and smooth work. The interface has been redesigned to display key machine information in a new user friendly interface. A rear view camera and a DEF level gauge display have been added to the default main screen. The interface has a function that enables the main screen mode to be switched, thus enabling the optimum screen information for the particular work situation to be displayed.

Indicators

- | | |
|------------------------------------|----------------------------|
| ① Auto-decelerator | ⑧ Fuel gauge |
| ② Working mode | ⑨ DEF level gauge |
| ③ Travel speed | ⑩ Service metre, clock |
| ④ Ecology gauge | ⑪ Fuel consumption gauge |
| ⑤ Camera display | ⑫ Guidance icon |
| ⑥ Engine coolant temperature gauge | ⑬ Function switches |
| ⑦ Hydraulic oil temperature gauge | ⑭ Camera direction display |
| | ⑮ DEF level caution lamp |

Basic operation switches

- | | |
|-------------------------|-------------------------|
| ① Auto-decelerator | ④ Buzzer cancel |
| ② Working mode selector | ⑤ Wiper |
| ③ Travel speed selector | ⑥ Window washer |
| | ⑦ Auto climate controls |

Switchable Display Modes

The main screen display mode can be changed by pressing the pressing the F3 key.



Visual user menu

Pressing the F6 key on the main screen displays the user menu screen. The menus are grouped for each function, and use easy-to-understand icons which enable the machine to be operated easily.



- ① Energy saving guidance
- ② Machine settings
- ③ Aftertreatment devices regeneration
- ④ SCR information
- ⑤ Maintenance
- ⑥ Monitor setting
- ⑦ Message check

Support Efficiency Improvement

Ecology guidance

While the machine is operating, ecology guidance pops up on the monitor screen to notify the operator of the status of the machine in real time.

Ecology gauge & fuel consumption gauge

The monitor screen is provided with an ecology gauge and also a fuel consumption gauge which is displayed continuously. In addition, the operator can set any desired target value of fuel consumption (within the range of the green display), enabling the machine to be operated with better fuel economy.



Ecology gauge Fuel consumption gauge
Ecology guidance

Operation record, fuel consumption history, and ecology guidance record

The ecology guidance menu enables the operator to check the operation record, fuel consumption history and ecology guidance record from the ecology guidance menu, using a single touch, thus assisting operators with reducing total fuel consumption.



Operation record



Fuel consumption history

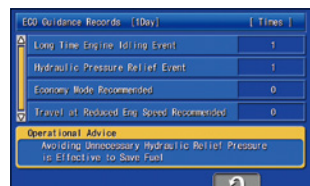

Ecology guidance record

Operator Identification Function

An operator identification ID can be set up for each operator, and used to manage operation information of individual machines using KOMTRAX data. Data sent from KOMTRAX can be used to analyse operation status by operator as well as by machine.



MAINTENANCE FEATURES

Centralised engine check points

Locations of the engine oil check and filters are integrated into one side to allow easy maintenance and service.



Engine oil filter

High efficiency fuel filter

Fuel pre-filter (with water separator)

Battery isolation switch

A standard battery isolation switch allows a technician to disconnect the power supply and lock out before servicing the machine.

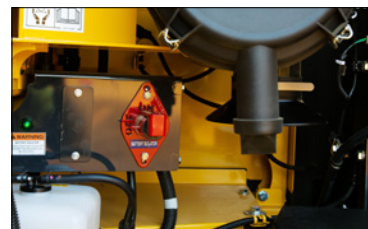

Easy to access air conditioner filter

Washable cab floormat

Sloping track frame

Utility space

Easy cleaning of coolers

Fuel pre-filter with water separator

High efficiency fuel filter

Easy access to engine oil filter, engine oil, drain valve, fuel drain valve and water separator drain valve



Long-life oils, filters

High performance filters are used in the hydraulic circuit and engine. By increasing the oil and filter replacement intervals, maintenance costs can be significantly reduced.

Engine oil & Engine oil filter	every 500 hours
Hydraulic oil	every 5000 hours
Hydraulic oil filter	every 1000 hours



Hydraulic oil filter (Ecology-white element)

Large capacity air cleaner

Large capacity air cleaner is comparable to that of larger machines. The larger air cleaner can extend air cleaner life during long-term operation and helps prevent early clogging, and resulting power loss. A radial seal design is used for reliability.

Diesel Exhaust Fluid (DEF) tank

A large tank volume extends operating time before refilling and is installed on the right front platform for easy access. DEF tank and pump are separated for improved service access.



Maintenance Information

“Maintenance time caution lamp” display

When the remaining time to maintenance becomes less than 30 hours*, a maintenance time monitor appears. Pressing the F6 key switches the monitor to the maintenance screen.

* : The setting can be changed within the range between 10 and 200 hours.



Maintenance screen

Manual Stationary Regeneration

Under most conditions, active regeneration will occur automatically with no effect on machine operation. In case the operator needs to disable active regeneration or initiate a manual stationary regeneration, this can be easily accomplished through the monitor panel. A soot level indicator is displayed to show how much soot is trapped in the KDPF.



Soot level indicator

Aftertreatment device regeneration screen

Supports the DEF level and refill timing

The DEF level gauge is displayed continuously on the right side of the monitor screen. In addition, when DEF level is low, DEF low level guidance messages appear in pop up displays to inform the operator in real time.

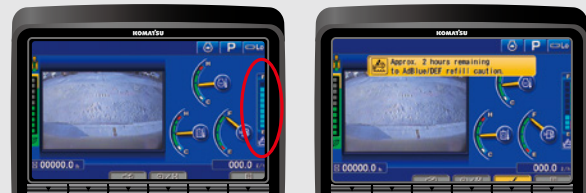

DEF level gauge

DEF low level guidance

DT-type connectors

Sealed DT-type electrical connectors provide high reliability, water and dust resistance.

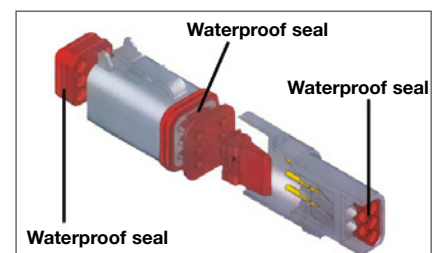

GENERAL FEATURES

ROPS CAB STRUCTURE

ROPS Cab (ISO 12117-2)

The machine is equipped with a ROPS cab that conforms to ISO 12117-2 for excavators as standard equipment. It also satisfies the requirements for Level 1 Operator Protective Guard (OPG) and top guard (ISO 10262).



Rear View Monitoring System

A new rear view monitoring system display has a rear view camera image that is continuously displayed together with the gauges and important vehicle information. This enables the operator to carry out work while easily checking the surrounding area.

Rear view camera



Rear view image on monitor



Low Vibration with Viscous Cab Mounts

The PC240LC-11 uses viscous mounts for the cab that incorporate a longer stroke and the addition of a spring. The cab damper mounting combined with a high rigidity deck reduces vibration at the operator's seat.

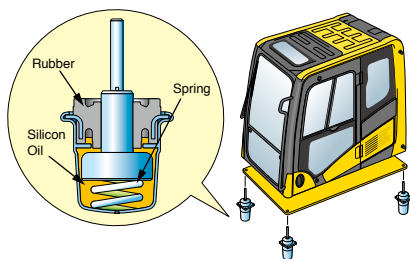

GENERAL FEATURES

Secondary engine shut down switch at base of seat to shutdown the engine.



Left and right side handrails



Seat belt caution indicator



Lock lever

Seat belt retractable

Tempered & tinted glass

Large mirrors

Slip-resistant plates

Thermal and fan guards

Pump/engine room partition

Travel alarm

Large cab entrance step



KALSS AUSTRALIAN STANDARD SPECIFICATION



Rotating Amber Beacon
Fitted with factory guard.



Level Indicator, Overload Alarm & Anti-Burst Valves
Enable safety and compliance when lifting suspended loads.



Additional Lighting
Extra lighting on cab and counterweight for improved visibility.



Proportional Hand Controls
Enables proportional hand control of attachment speed.



Higher Capacity Air Conditioner
With increased cool down performance.

Rock Guard
Reinforced steel plate and ribs to provide additional protection of arm structure.

Bump Rails
For upper protection when slewing.

Factory Fitted Quick Hitch and Hammer Piping
Enables use with a greater variety of attachments. Also fitted with provision for tilt circuit including valve.

Revolving Frame Under Covers
Protects and prevents ingress of material into engine bay.



Lower Front Window Guard
Protects cabin windscreen against rocks and debris.



Battery Isolation
Single pole, lockable Bosch-type battery isolation.



E-Stops
Allow compliance to site safety requirements.



Bolt-on Top Guard
OPG level 2 (ISO 10262) for falling object protection.

Specification also includes factory fitted provisions for fire extinguisher, turbo timer, UHF and vandal covers to reduce lead times and costs. Photos may include optional equipment.

SPECIFICATIONS



ENGINE

Model..... Komatsu SAA6D107E-3*
 Type..... Water-cooled, 4-cycle, direct injection
 Aspiration..... Variable geometry turbocharged,
 aftercooled, cooled EGR
 Number of cylinders..... 6
 Bore..... **107 mm** 4.21"
 Stroke..... **124 mm** 4.88"
 Piston displacement..... **6.69 ltr** 408 in³
 Horsepower:
 SAE J1995..... Gross **141 kW** 189 HP
 ISO 9249 / SAE J1349..... Net **132 kW** 177 HP
 Rated rpm..... 2000
 Fan drive method for radiator cooling..... Mechanical
 Governor..... All-speed control, electronic
 *EPA Tier 4 Final emissions certified



HYDRAULICS

Type..... HydrauMind (Hydraulic Mechanical Intelligence)
 system, closed-centre system with load sensing valves and
 pressure compensated valves
 Number of selectable working modes..... 6
 Main pump:
 Type..... Variable displacement piston type
 Pumps for..... Boom, arm, bucket, swing, and travel circuits
 Maximum flow..... **490 ltr/min** 129.4 gal/min
 Supply for control circuit..... Self-reducing valve
 Hydraulic motors:
 Travel..... 2 x axial piston motors with parking brake
 Swing..... 1 x axial piston motor with swing holding brake
 Relief valve setting:
 Implement circuits..... **37.3 MPa 380 kgf/cm²** 5,400 psi
 Travel circuit..... **37.3 MPa 380 kgf/cm²** 5,400 psi
 Swing circuit..... **28.9 MPa 295 kgf/cm²** 4,190 psi
 Pilot circuit..... **3.2 MPa 33 kgf/cm²** 470 psi

Hydraulic cylinders:

(Number of cylinders – bore x stroke x rod diameter)

Boom ... **2-135 mm x 1335 mm x 95 mm** 5.3" x 52.6" x 3.7"
 Arm **1-140 mm x 1635 mm x 100 mm** 5.5" x 64.4" x 3.9"
 Bucket ... **1-130 mm x 1020 mm x 90 mm** 5.1" x 40.2" x 3.5"



DRIVES AND BRAKES

Steering control..... Two levers with pedals
 Drive method..... Hydrostatic
 Maximum drawbar pull..... **202 kN 20570 kg** 45,349 lb
 Gradeability..... 70%, 35°
 Maximum travel speed (auto-shift):
 High..... **5.5 km/h** 3.4 mph
 Mid..... **4.1 km/h** 2.5 mph
 Low..... **3.0 km/h** 1.9 mph
 Service brake..... Hydraulic lock
 Parking brake..... Mechanical disc brake



SWING SYSTEM

Drive method..... Hydrostatic
 Swing reduction..... Planetary gear
 Swing circle lubrication..... Grease-bathed
 Service brake..... Hydraulic lock
 Holding brake/Swing lock..... Mechanical disc brake
 Swing speed..... 11.7 rpm
 Swing torque..... **8065 kg•m** 58,334 ft lbs



UNDERCARRIAGE

Centre frame..... X-frame
 Track frame..... Box-section
 Seal of track..... Sealed track
 Track adjuster..... Hydraulic
 Number of shoes (each side)..... 51
 Number of carrier rollers (each side)..... 2
 Number of track rollers (each side)..... 10



COOLANT & LUBRICANT CAPACITY (REFILLING)

Fuel tank..... **400 ltr** 105.7 U.S. gal
 Coolant..... **36 ltr** 9.5 U.S. gal
 Engine..... **23.1 ltr** 6.1 U.S. gal
 Final drive, each side..... **5.0 ltr** 1.3 U.S. gal
 Swing drive..... **7.2 ltr** 1.9 U.S. gal
 Hydraulic tank..... **132 ltr** 34.9 U.S. gal
 Hydraulic system..... **244 ltr** 64.4 U.S. gal
 DEF tank..... **23.1 ltr** 6.1 U.S. gal



OPERATING WEIGHT (APPROXIMATE)

Operating weight includes **5900 mm** one-piece HD boom,
3000 mm HD arm, rated capacity of lubricants, coolant, full
 fuel tank, operator, standard equipment, KGA dual lock quick
 hitch, and SAE heaped **1.08 m³** bucket.

Triple-Grouser Shoes	Operating Weight	Ground Pressure
600 mm	25,640 kg	0.52 kg/cm ²
700 mm	25,940 kg	0.45 kg/cm ²
800 mm	26,240 kg	0.40 kg/cm ²

Component Weights

Arm including bucket cylinder and linkage
3000 mm 10'0" HD arm assembly..... **1318 kg** 2,906 lb
 One piece HD boom including arm cylinder
5900 mm 20'2" boom assembly..... **2148 kg** 4,736 lb
 Boom cylinders x 2..... **210 kg** 463 lb
 Counterweight..... **4670 kg** 10,296 lb



DIMENSIONS

	Arm Length	3000 mm
A	Overall length	9965 mm
B	Length on ground (transport)	5390 mm
C	Overall height (to top of boom)*	3185 mm
D	Overall width	3180 mm
E	Overall height (to top of cab)*	3055 mm
F	Overall height (to top of handrail)*	3150 mm
G	Ground clearance, counterweight	1100 mm
H	Ground clearance, minimum	440 mm
I	Tail swing radius	3020 mm
J	Track length on ground	3845 mm
K	Track length	4640 mm
L	Track gauge	2580 mm
M	Width of crawler	3180 mm
N	Shoe width	600 mm
O	Grouser height	26 mm
P	Machine height to top of counterweight	2265 mm
Q	Machine height to top of engine cover	2780 mm
R	Machine upper width	2850 mm
S	Distance, swing centre to rear end	2985 mm

* : Including grouser height

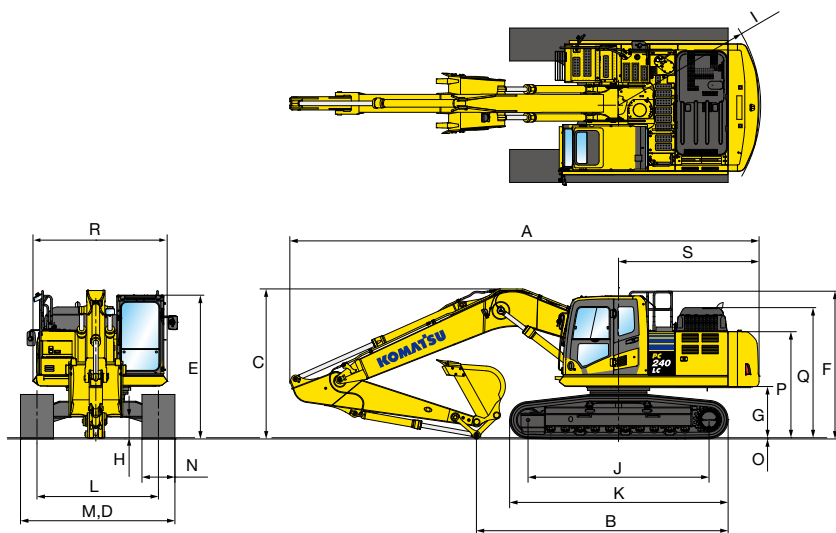

WORKING RANGE

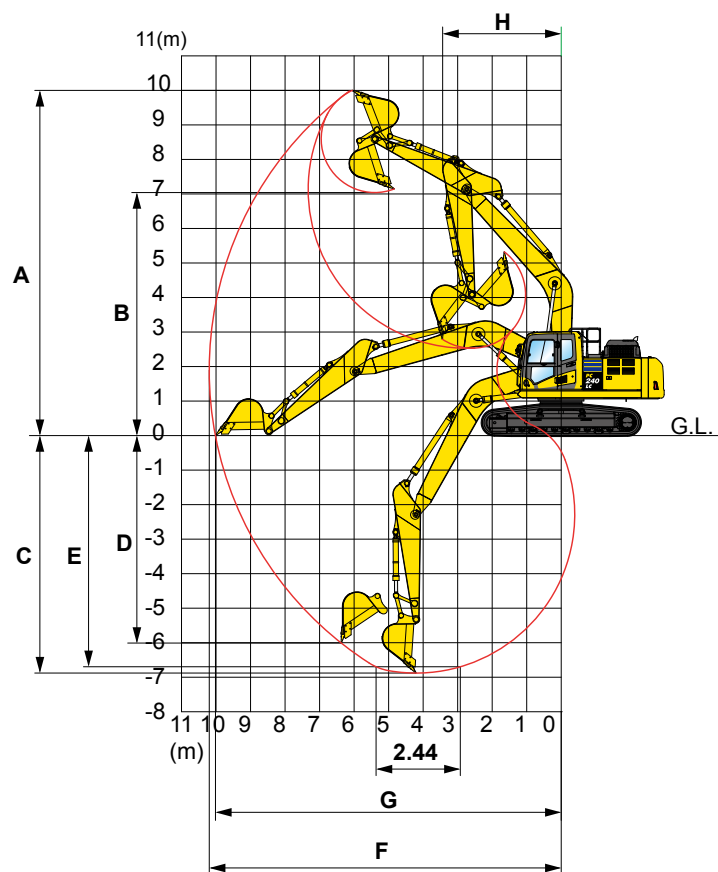

	Arm Length	3000 mm
A	Max. digging height	10000 mm
B	Max. dumping height	7035 mm
C	Max. digging depth	6920 mm
D	Max. vertical wall digging depth	6010 mm
E	Max. digging depth for 8' level bottom	6700 mm
F	Max. digging reach	10180 mm
G	Max. digging reach at ground level	10020 mm
H	Min. swing radius	3450 mm
SAE rating	Bucket digging force at power max.	152 kN 15500 kg
	Arm crowd force at power max.	119 kN 12100 kg
	Bucket digging force at power max.	172 kN 17500 kg
ISO rating	Bucket digging force at power max.	172 kN 17500 kg
	Arm crowd force at power max.	129 kN 13200 kg

LIFT CAPACITIES



LIFTING CAPACITY WITH LIFTING MODE

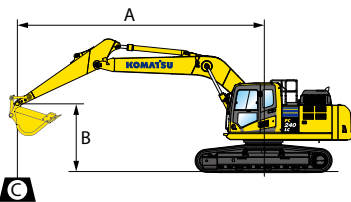

- A: Reach from swing centre
- B: Bucket hook height
- C: Lifting capacity
- Cf: Rating over front
- Cs: Rating over side
- ⊗: Rating at maximum reach

- Conditions:
- Boom length: 5900 mm
 - Arm Length: 3000 mm
 - Shoes: 600 mm triple grouser
 - Bucket: 730 kg

Unit: kg

B \ A	1.5 m		3.0 m		4.5 m		6.0 m		7.5 m		⊗ MAX	
	Cf	Cs	Cf	Cs	Cf	Cs	Cf	Cs	Cf	Cs	Cf	Cs
6.0 m							*4950	*4950	*4700	4350	*3300	*3200
4.5 m							*5900	*5900	*5600	4250	*3250	*3250
3.0 m			*11900	*11900	*9650	9300	*7300	5950	*6300	4100	*3400	3050
1.5 m			*6700	*6700	*12450	8700	*8750	5600	6100	3900	*3750	2950
0 m			*8250	*8250	13800	8250	8550	5350	5950	3750	*4250	3000
-1.5 m	*7650	*7650	*9900	*9900	13750	8100	8350	5200	5850	3700	5150	3250
-3.0 m	*10650	*10650	*18400	16800	*13750	8150	8350	5150	5900	3700	6050	3800
-4.5 m			*18150	*17050	*12600	8350	8550	5350			8300	5200

*Load is limited by hydraulic capacity rather than tipping. Ratings are based on SAE standard No. J1097. Rated loads do not exceed 87% of hydraulic lift capacity or 75% of tipping load.



PC240LC-11



STANDARD EQUIPMENT

- 3 speed travel with auto shift
- Alternator, 90 Ampere, 24 V
- AM/FM radio
- Arm, 3000 mm
- Auto idle
- Auto idle shut down
- Automatic air conditioner, large capacity
- Automatic engine warm-up system
- Auxiliary input (3.5 mm jack)
- Batteries, large capacity
- Battery isolation switch, lockable
- Boom, 5900 mm
- Boom and arm burst valve protection
- Bump rails
- Cab guards
 - Lower front window guard
 - Integrated top guard, OPG Level 1
 - Bolt on top guard, OPG Level 2
- Carrier rollers, (2 each side)
- Converter, (2) x 12 V
- Counterweight, 4670 kg
- Dry type air cleaner, double element
- Dual flow hammer piping
- Electric horn
- Emergency stops (3)
- EMMS monitoring system
- Engine, Komatsu SAA6D107E-3
- Engine overheat prevention system
- Fan guard structure
- Fuel system pre-filter 10 micron
- High back air suspension seat, with heat
- High pressure in-line hydraulic filters
- Hydraulic track adjusters
- Hydraumind closed centre load sensing system
- KOMTRAX Level 5.0
- Large LCD colour monitor, high resolution
- Level indicator
- Lock lever
- Lock lever, Auto-lock
- Mirrors (LH, RH & sidewise)
- Operator identification system
- Overload alarm
- Power maximising system
- PPC hydraulic control system
- Proportional control handles
- Provision for tilt circuit, including valve
- Pump/engine room partition cover
- Quick hitch piping with safety switch and alarm
- Radiator and oil cooler dustproof net
- Rear reflectors
- Rearview monitoring system (1 camera)
- Revolving frame undercovers
- ROPS cab (ISO 12117-2) with vandal guard provisions
- Rotating beacon with guard
- Seat belt indicator
- Seat belt, retractable, 78 mm
- Secondary engine shutdown switch
- Side by side coolers
- Slip resistant foot plates
- Starter motor, 5.5 kW / 24 V x 1
- Suction fan
- Thermal and fan guards
- Track frame swivel guard
- Track roller guides, 3 each side
- Track rollers, 10 each side
- Track shoes, triple grouser, 600 mm
- Travel alarm
- Working lights
 - 1 x boom
 - 1 x RH
 - 3 x cab
 - 1 x counterweight
- Working mode selection system



OPTIONAL EQUIPMENT

- Autogrease system
- Battery isolation switch, dual pole, lockable
- Belly plates, 8 mm
- Cab guard
 - Full front guard, OPG Level 2
- Canvas seat cover
- Fire extinguisher, 1.5 kg
- Fire extinguisher, 4.5 kg
- Fuel cap vandal guard
- Jump start receptacle
- Radio, multimedia system
- Radio, UHF
- Starter circuit isolation, lockable
- Track roller guards, full length
- Track shoes, triple grouser, 800 mm
- Turbo time
- Window tinting



ATTACHMENT OPTIONS

- Bucket, general purpose, KGA 600 mm, 0.43 m³
- Bucket, general purpose, KGA 900 mm, 0.75 m³
- Bucket, general purpose, KGA 1200 mm, 1.08 m³
- Bucket, slope finishing, KGA 2000 mm, 1.64 m³
- Quick hitch, KGA, dual lock
- Quick hitch, KGA, dual lock, tilting
- Ripper, KGA, single tyne

COMING SOON

KOMATSU JMHB230V-1 Hydraulic Breaker

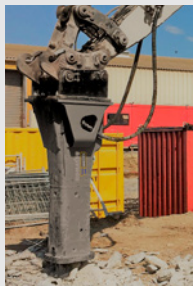

Model Type	JMHB230V-1	
Working weight	kg	1,450
Oil flow (min - max)	ℓ /min	120 - 170
Operating pressure (max)	MPa	135
Impact rate	bpm	285 - 1,050
Chisel diameter	mm	122
Acceptable back pressure	bar	8
Base machine (min - max)	Ton	18 - 30

For a complete list of available attachments, please contact your local Komatsu representative.

