

# KOMATSU®

# PC210/LC-11

EPA Tier 4 Final Engine

Australia & New Zealand Specifications

HYDRAULIC EXCAVATOR



Photos may include optional equipment.

**NET HORSEPOWER**

123 kW / 165 HP @ 2000 rpm

**OPERATING WEIGHT**

PC210-11: 22,410 – 23,180 kg  
PC210LC-11: 23,000 – 23,830 kg

**BUCKET CAPACITY**

0.39 – 0.97 m<sup>3</sup>

PC210/LC

# WALK-AROUND

PC210/LC-11



Photos may include optional equipment.

## NET HORSEPOWER

123 kW / 165 HP @ 2000 rpm

## OPERATING WEIGHT

PC210-11: 22,410 – 23,180 kg  
PC210LC-11: 23,000 – 23,830 kg

## BUCKET CAPACITY

0.39 – 0.97 m<sup>3</sup>

## PERFORMANCE & EFFICIENCY

**New engine and hydraulic control technology** improves operational efficiency and lowers fuel consumption by up to 7%.

### Komatsu Harmony

All major components are designed and manufactured by Komatsu. A fully integrated design produces an efficient, reliable system.

A powerful **Komatsu SAA6D107E-3 engine** provides a net output of 123 kW 165 HP. This engine is EPA Tier 4 Final emissions certified.

**Komatsu Variable Geometry Turbocharger (KVGIT)** uses a hydraulic actuator to provide optimum air flow under all speed and load conditions.

**Komatsu Diesel Particulate Filter (KDPF) and Selective Catalytic Reduction (SCR) system** reduce particulate matter and NOx while providing automatic regeneration that does not interfere with daily operation.

**Large displacement high efficiency pumps** provide high flow output at low engine speed, improving efficiency.

**Komatsu's Closed-centre Load Sensing System (CLSS)** provides quick response and smooth operation to maximise productivity.

**Enhanced working modes** are designed to match engine speed, pump delivery, and system pressure to the application.

The **KOMTRAX®** telematics system is standard on Komatsu equipment with no subscription fees. Using the latest wireless technology, **KOMTRAX®** transmits valuable information such as location, utilisation, and maintenance records to a PC or smartphone app. Custom machine reports are provided for identifying machine efficiency and operating trends. **KOMTRAX®** also provides advanced machine troubleshooting capabilities by continuously monitoring machine health.

### Large LCD colour monitor panel:

- 7" high resolution screen
- Provides "Ecology Guidance" for fuel efficient operation
- Enhanced attachment control

### Rearview monitoring system (standard)



**Equipment Management Monitoring System (EMMS)** continuously monitors machine operation and vital systems to identify machine issues and assist with troubleshooting.

### Enhanced working environment

- High back, heated air suspension operator seat with new adjustable arm rests
- Integrated ROPS cab design
- Cab meets ISO Level 1 Operator Protective Guard (OPG) top guard
- Aux jack and (2) 12V power outlets

### Komatsu designed and manufactured components

**Wide access service doors** provide easy access for ground level maintenance.

**Handrails (standard)** on both sides provide more convenient access to the upper structure.

**Lockable single pole battery isolation switch** allows a technician to disconnect the power supply before servicing the machine.

**Komatsu Auto Idle Shutdown** helps reduce idle time and operating costs.

**Operator Identification System** can track machine operation for more than 100 operators.

# PERFORMANCE FEATURES

## KOMATSU NEW ENGINE TECHNOLOGIES

### New Tier 4 Final Engine

The Komatsu SAA6D107E-3 engine is EPA Tier 4 Final emissions certified and provides exceptional performance while reducing fuel consumption. Based on Komatsu proprietary technologies developed over many years, this new diesel engine reduces particulate matter (PM) and nitrogen oxides (NOx) by 90% when compared to Tier 3 levels. Through the in-house development and production of engines, electronics, and hydraulic components, Komatsu has achieved great advancements in technology, providing high levels of performance and efficiency in virtually all applications.

### Technologies Applied to New Engine

#### Heavy-duty aftertreatment system

This new system combines a Komatsu Diesel Particulate Filter (KDPF) and Selective Catalytic Reduction (SCR). The SCR NOx reduction system injects the correct amount of Diesel Exhaust Fluid (DEF) at the proper rate, thereby decomposing NOx into non-toxic water vapour (H<sub>2</sub>O) and nitrogen gas (N<sub>2</sub>).

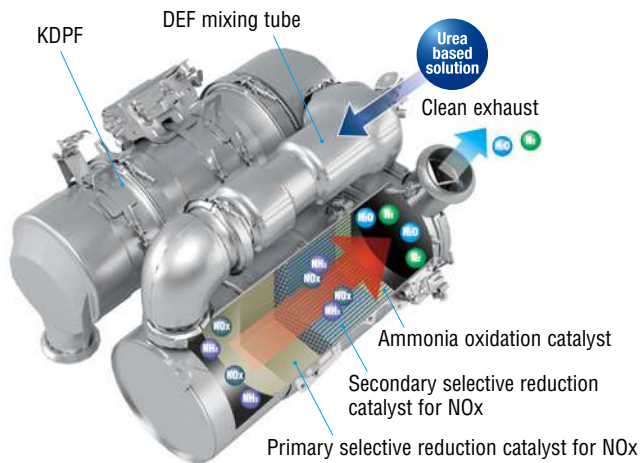

#### Heavy-duty cooled Exhaust Gas Recirculation (EGR) system

The system recirculates a portion of exhaust gas into the air intake and lowers combustion temperatures to reduce NOx emissions. Furthermore, while EGR gas flow is increased, by incorporating a high-efficiency and compactly designed cooling system, the system achieves a dynamic reduction of NOx, while helping reduce fuel consumption.

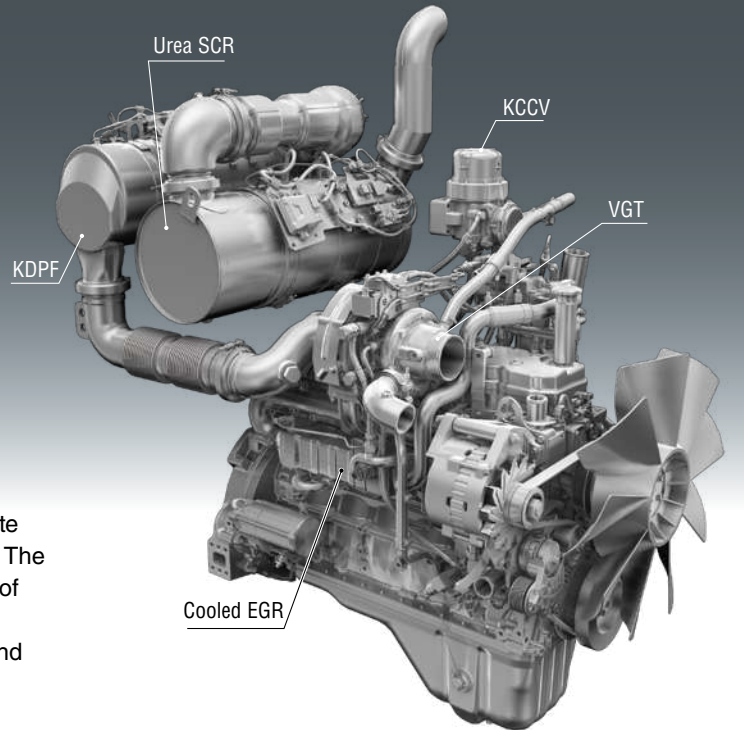
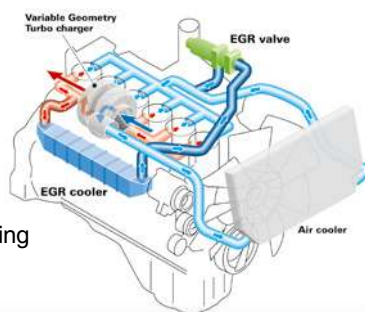

#### Advanced Electronic Control System

The electronic control system performs high-speed processing of all signals from sensors installed in the vehicle providing total control of equipment in all conditions of use. Engine condition information is displayed via an on-board network to the monitor inside the cab, providing necessary information to the operator. Additionally, managing the information via KOMTRAX helps customers keep up with required maintenance.

#### Komatsu Variable Geometry Turbocharger (KVG) system

The VGT system features proven Komatsu designed hydraulic technology for variable control of air-flow and supplies optimal air according to load conditions. The upgraded version provides better exhaust temperature management.

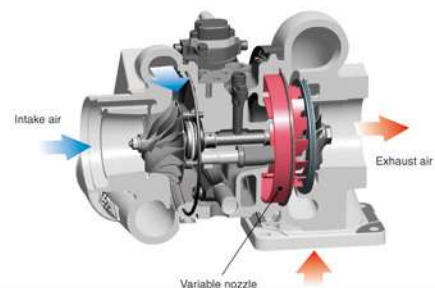

### Komatsu Auto Idle Shutdown

Komatsu auto idle shutdown automatically shuts the engine down after idling for a set period of time to reduce unnecessary fuel consumption and exhaust emissions.



### Heavy-Duty High-Pressure Common Rail (HPCR) Fuel Injection System

The system is designed to achieve an optimal injection of high-pressure fuel by means of computerised control, providing close to complete combustion to reduce PM emissions. While this technology is already used in current engines, the new system uses high pressure injection, thereby reducing PM emissions over the entire range of engine operating conditions. The Tier 4 Final engine has advanced fuel injection timing for reduced soot levels.

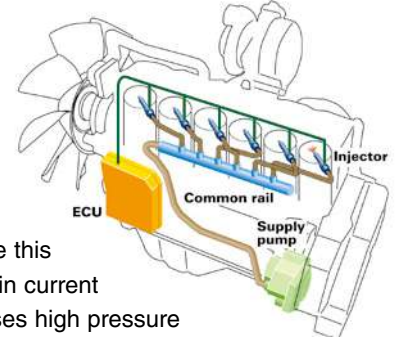

# PERFORMANCE FEATURES

## Reduced Fuel Consumption

The PC210LC-11's new tier 4 final engine along with enhancements in the hydraulic system considerably decreases fuel consumption.

### Fuel consumption

**Reduced by up to 7%**

(vs PC200LC-8M0 based on typical work pattern collected via KOMTRAX)

This fuel consumption data is the result compared actual measured value using the prototype machine. Actual fuel savings may vary depending on application and operating conditions.

## Increased Work Efficiency

### Powerful digging force

Functional digging force can be increased with use of the one-touch Power Max. function (up to 8.5 seconds of operation).

### Maximum arm crowd force (ISO)

**101 kN(10.3t) ➔ 108 kN(11.0t) 7% UP**  
(with Power Max.)

### Maximum bucket digging force (ISO)

**138 kN(14.1t) ➔ 149 kN(15.2t) 8% UP**  
(with Power Max.)

Measured with Power Max. function, 2900 mm arm and ISO rating



## Efficient Hydraulic System

The PC210/LC-11 uses a Closed-centre Load Sensing System (CLSS) that improves fuel efficiency and provides quick response to the operator's demands. The PC210/LC-11 also incorporates new technology to enhance the engine and hydraulic pump control. This total control system matches the engine and hydraulics at the most efficient point under any load condition. There have also been improvements in the main valve and hydraulic circuit to reduce hydraulic loss, resulting in higher efficiency and lower fuel consumption.



## Large Displacement High Efficiency Pump

Large displacement hydraulic implement pumps provide high flow output at lower engine RPM as well as operation at the most efficient engine speed.



## Working Mode Selection

The PC210/LC-11 excavator is equipped with six working modes (P, E, L, B, ATT/P and ATT/E). An enhanced Power Mode provides improved hydraulic power and faster cycle times for improved performance in demanding applications. Each mode is designed to match engine speed, pump flow, and system pressure to the application. The PC210/LC-11 features an attachment mode (ATT/E) that allows operators to run attachments while in Economy mode.

Working Mode	Application	Advantage
<b>P</b>	Power Mode	•Maximum production, power & multifunction
<b>E</b>	Economy Mode	•Good cycle times with reduced fuel consumption
<b>L</b>	Lifting Mode/ Fine Control	•Increased lifting power & fine control
<b>B</b>	Breaker Mode	•One way flow for hydraulic breaker operation
<b>ATT/P</b>	Attachment Power Mode	•Two way flow with maximum power
<b>ATT/E</b>	Attachment Economy Mode	•Two way flow with most efficient fuel economy

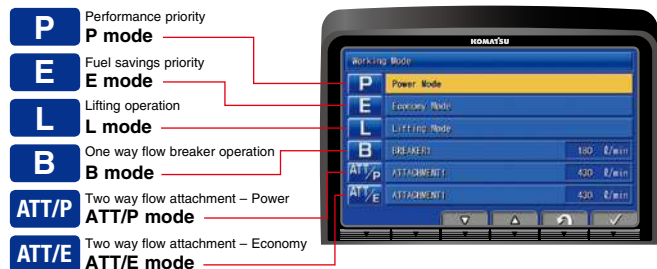

## High Rigidity Work Equipment

Booms and arms are constructed with thick plates of high tensile strength steel. In addition, these structures are designed with large cross sectional areas and large one piece castings in the boom foot, the boom tip, and the arm tip. The result is work equipment that exhibits long term durability and high resistance to bending and torsional stress. A standard HD boom design provides increased strength and reliability.



# WORKING ENVIRONMENT

PG210/LG-11





**Comfortable Working Space**

**Wide spacious cab**

The wide spacious cab includes a heated air suspension seat with reclining backrest. The seat height and position are easily adjusted using a pull-up lever. The armrest position is easily adjusted together with the console.

**Arm rest with simple height adjustment function**

A knob and plunger on the armrests allows easy height adjustment without the use of tools.



**Low vibration with cab damper mounting**

**Automatic climate control**

**Pressurised cab**

**Auxiliary input jack**

Connecting a regular audio device to the auxiliary jack allows the operator to hear the sound from the stereo speakers installed in the cab.



**Standard Equipment**

Sliding window glass (left side)



AM/FM stereo radio



Remote intermittent wiper with windshield washer



Emergency stop & level indicator



ISO Level 2 OPG



Magazine box & cup holder



Defroster (conform to the ISO standard)



One-touch storable front window lower glass



# WORKING ENVIRONMENT

PG210/LG-11

## LARGE HIGH RESOLUTION LCD MONITOR



### New Monitor Panel Interface Design

An updated large high resolution LCD colour monitor enables accurate and smooth work. The interface has been redesigned to display key machine information in a new user friendly interface. A rear view camera and a DEF level gauge display have been added to the default main screen. The interface has a function that enables the main screen mode to be switched, thus enabling the optimum screen information for the particular work situation to be displayed.

#### Indicators

- |                                    |                             |
|------------------------------------|-----------------------------|
| 1 Auto-decelerator                 | 8 Fuel gauge                |
| 2 Working mode                     | 9 DEF level gauge           |
| 3 Travel speed                     | 10 Service metre, clock     |
| 4 Ecology gauge                    | 11 Fuel consumption gauge   |
| 5 Camera display                   | 12 Guidance icon            |
| 6 Engine coolant temperature gauge | 13 Function switches        |
| 7 Hydraulic oil temperature gauge  | 14 Camera direction display |
|                                    | 15 DEF level caution lamp   |

#### Basic operation switches

- |                         |                         |
|-------------------------|-------------------------|
| 1 Auto-decelerator      | 4 Buzzer cancel         |
| 2 Working mode selector | 5 Wiper                 |
| 3 Travel speed selector | 6 Window washer         |
|                         | 7 Auto climate controls |

### Switchable Display Modes

The main screen display mode can be changed by pressing the F3 key.

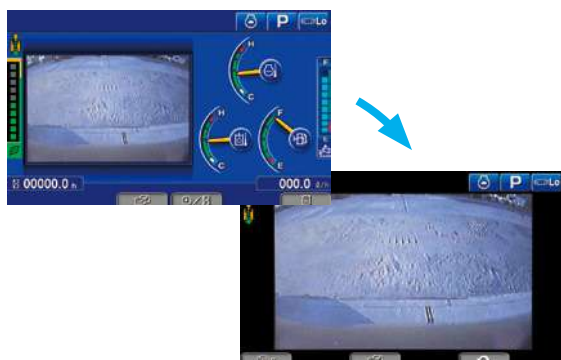

### Visual user menu

Pressing the F6 key on the main screen displays the user menu screen. The menus are grouped for each function, and use easy-to-understand icons which enable the machine to be operated easily.



- |                                       |                    |
|---------------------------------------|--------------------|
| 1 Energy saving guidance              | 2 Machine settings |
| 3 Aftertreatment devices regeneration | 4 SCR information  |
| 5 Maintenance                         | 6 Monitor setting  |
|                                       | 7 Message check    |

## Support Efficiency Improvement

### Ecology guidance

While the machine is operating, ecology guidance pops up on the monitor screen to notify the operator of the status of the machine in real time.

### Ecology gauge & fuel consumption gauge

The monitor screen is provided with an ecology gauge and also a fuel consumption gauge which is displayed continuously. In addition, the operator can set any desired target value of fuel consumption (within the range of the green display), enabling the machine to be operated with better fuel economy.



Ecology gauge      Fuel consumption gauge  
Ecology guidance

### Operation record, fuel consumption history, and ecology guidance record

The ecology guidance menu enables the operator to check the operation record, fuel consumption history and ecology guidance record from the ecology guidance menu, with a single touch, thus assisting operators with reducing total fuel consumption.



Operation record



Fuel consumption history

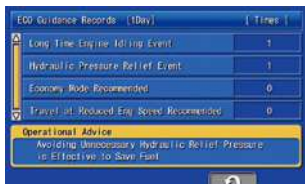

Ecology guidance record

### Operator Identification Function

An operator identification ID can be set up for each operator, and used to manage operation information of individual machines using KOMTRAX data. Data sent from KOMTRAX can be used to analyse operation status by operator as well as by machine.



# MAINTENANCE FEATURES

## Centralised engine check points

Locations of the engine oil check and filters are integrated into one side to allow easy maintenance and service.

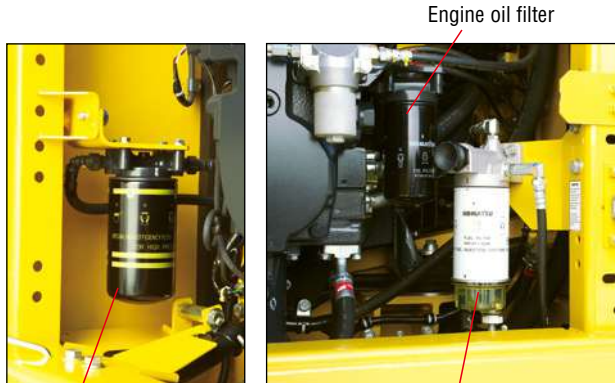

High efficiency fuel filter

Fuel pre-filter (with water separator)

## Battery isolation switch

A standard battery isolation switch allows a technician to disconnect the power supply and lock out before servicing the machine.



## Easy access air conditioner filter

## Washable cab floor mat

## Sloping track frame

## Utility space

## Easy cleaning of coolers

## Fuel pre-filter with water separator

## High efficiency fuel filter

## Easy access to engine oil filter, engine oil, drain valve, fuel drain valve and water separator drain valve

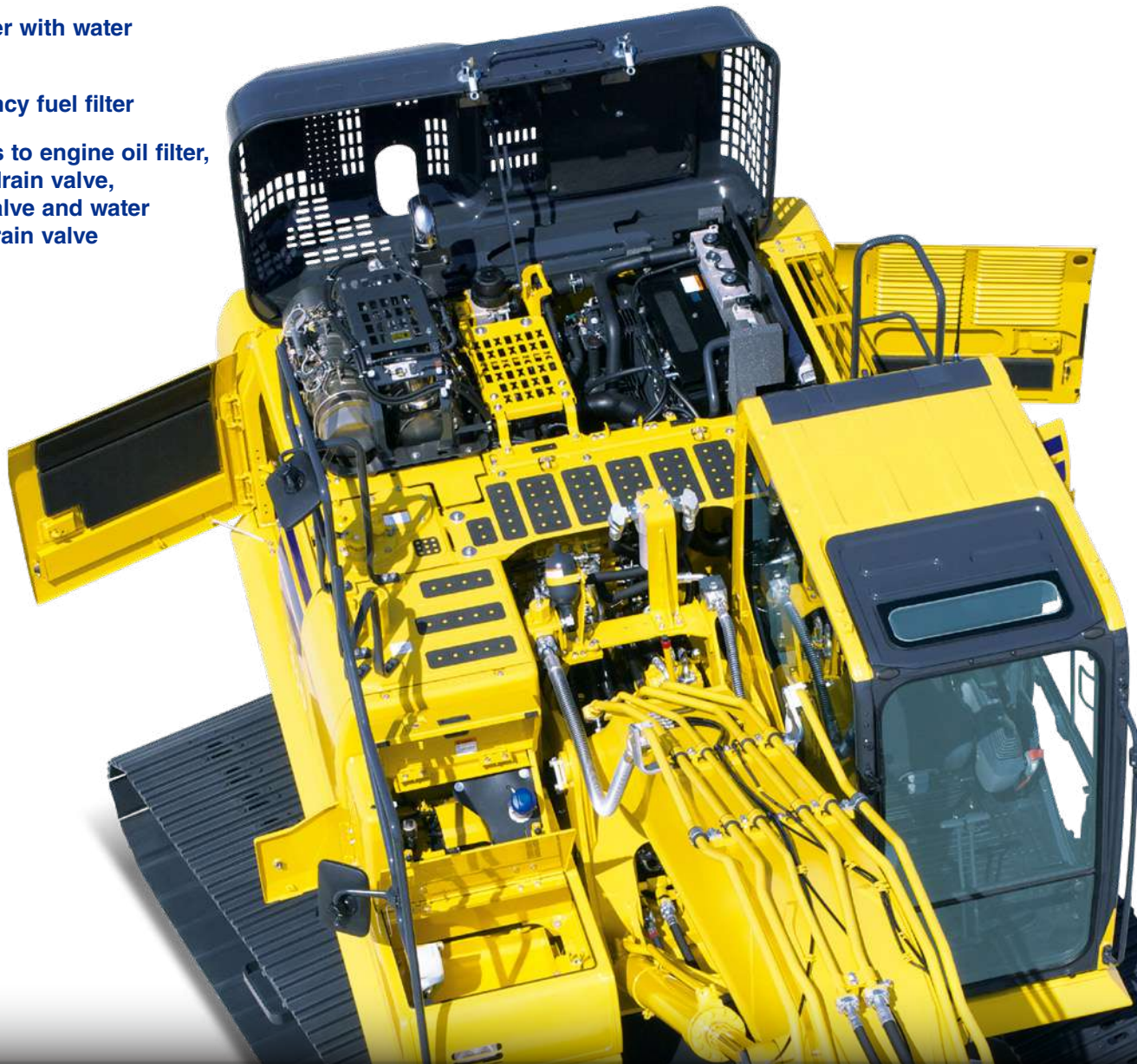

PG210/LG-11

**Long-life oils, filters**

High performance filters are used in the hydraulic circuit and engine. By increasing the oil and filter replacement intervals, maintenance costs can be significantly reduced.

Engine oil & Engine oil filter	every 500 hours
Hydraulic oil	every 5000 hours
Hydraulic oil filter	every 1000 hours
DEF pump filter	every 2000 hours



Hydraulic oil filter (Ecology-white element)

**Large capacity air cleaner**

Large capacity air cleaner is comparable to that of larger machines. The larger air cleaner can extend air cleaner life during long-term operation and helps prevent early clogging, and resulting power loss. A radial seal design is used for reliability.

**Diesel Exhaust Fluid (DEF) tank**

A large tank volume extends operating time before refilling and is installed on the right front platform for easy access. DEF tank and pump are separated for improved service access.



**Maintenance Information**

**“Maintenance time caution lamp” display**

When the remaining time to maintenance becomes less than 30 hours\*, a maintenance time monitor appears. Pressing the F6 key switches the monitor to the maintenance screen.

\* : The setting can be changed within the range between 10 and 200 hours.



Maintenance screen

**Manual Stationary Regeneration**

Under most conditions, active regeneration will occur automatically with no effect on machine operation. In case the operator needs to disable active regeneration or initiate a manual stationary regeneration, this can be easily accomplished through the monitor panel. A soot level indicator is displayed to show how much soot is trapped in the KDPF.

Soot level indicator



Aftertreatment device regeneration screen

**Supports the DEF level and refill timing**

The DEF level gauge is displayed continuously on the right side of the monitor screen. In addition, when DEF level is low, DEF low level guidance messages appear in pop up displays to inform the operator in real time.



DEF level gauge



DEF low level guidance

**DT-type connectors**

Sealed DT-type electrical connectors provide high reliability, water and dust resistance.

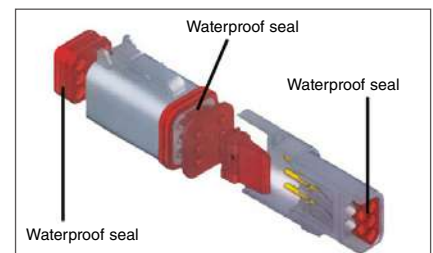

# GENERAL FEATURES

## ROPS CAB STRUCTURE

### ROPS Cab (ISO 12117-2)

The machine is equipped with a ROPS cab that conforms to ISO 12117-2 for excavators as standard equipment. It also satisfies the requirements for Level 1 Operator Protective Guard (OPG) and top guard (ISO 10262).



### Rear View Monitoring System

A new rear view monitoring system display has a rear view camera image that is continuously displayed together with the gauges and important vehicle information. This enables the operator to carry out work while easily checking the surrounding area.

Rear view camera



Rear view image on monitor



### Low Vibration with Viscous Cab Mounts

The PC210/LC-11 uses viscous mounts for the cab that incorporate a longer stroke and the addition of a spring. The cab damper mounting combined with a high rigidity deck reduces vibration at the operator's seat.

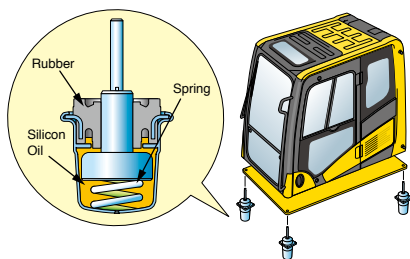

## GENERAL FEATURES

**Secondary engine shut down switch** at base of seat to shutdown the engine.



**Lock lever**

**Seat belt retractable**

**Tempered & tinted glass**

**Large mirrors**

**Slip-resistant plates**

**Thermal and fan guards**

**Pump/engine room partition**

**Travel alarm**

**Large cab entrance step**

**Left and right side handrails**



**Seat belt caution indicator**



# KALSS AUSTRALIAN STANDARD SPECIFICATION



### Rotating Amber Beacon

Fitted with factory guard.



### Level Indicator, Overload Alarm & Anti-Burst Valves

Enable safety and compliance when lifting suspended loads.



### Additional Lighting

Extra lighting on cab and counterweight for improved visibility.



### Proportional Hand Controls

Enables proportional hand control of attachment speed.



### Rock Guard

Reinforced steel plate and ribs to provide additional protection of arm structure.

### Higher Capacity Air Conditioner

With increased cool down performance.

### Bump Rails

For upper protection when slewing.

### Factory Fitted Quick Hitch and Hammer Piping

Enables use with a greater variety of attachments. Also fitted with provision for tilt circuit including valve.

Image for illustrative purposes only. US model shown.

### Revolving Frame Under Covers

Protects and prevents ingress of material into engine bay.



### Lower Front Window Guard

Protects cabin windscreen against rocks and debris.



### Battery Isolation

Single pole, lockable Bosch-type battery isolation.



### E-Stops

Allow compliance to site safety requirements.



### Bolt-on Top Guard

OPG level 2 (ISO 10262) for falling object protection.

Specification also includes factory fitted provisions for fire extinguisher, turbo timer, UHF and vandal covers to reduce lead times and costs. Photos may include optional equipment.

# SPECIFICATIONS



## ENGINE

Model ..... Komatsu SAA6D107E-3\*  
 Type ..... Water-cooled, 4-cycle, direct injection  
 Aspiration ..... Variable geometry turbocharged, aftercooled, cooled EGR  
 Number of cylinders ..... 6  
 Bore ..... **107 mm** 4.21"  
 Stroke ..... **124 mm** 4.88"  
 Piston displacement ..... **6.69 ltr** 408 in<sup>3</sup>  
 Horsepower  
 ISO 9249 / SAE J1349 ..... Net **122.8 kW** 165 HP  
 Fan at maximum speed ..... Net **118.6 kW** 159 HP  
 Rated rpm ..... 2000  
 Fan drive method for cooling radiator ..... Mechanical with viscous fan clutch  
 Governor ..... All-speed control, electronic  
 \*EPA Tier 4 Final emissions certified



## HYDRAULICS

Type ..... HydrauMind (Hydraulic Mechanical Intelligence) system, closed-centre system with load sensing valves and pressure compensated valves  
 Number of selectable working modes ..... 6  
 Main pump:  
 Type ..... Variable displacement piston type  
 Pumps for ..... Boom, arm, bucket, swing, and travel circuits  
 Maximum flow ..... **490 ltr/min** 129.4 gal/min  
 Supply for control circuit ..... Self-reducing valve  
 Hydraulic motors:  
 Travel ..... 2 x axial piston motors with parking brake  
 Swing ..... 1 x axial piston motor with swing holding brake  
 Relief valve setting:  
 Implement circuits ..... **37.3 MPa 380 kgf/cm<sup>2</sup>** 5,400 psi  
 Travel circuit ..... **37.3 MPa 380 kgf/cm<sup>2</sup>** 5,400 psi  
 Swing circuit ..... **28.9 MPa 295 kgf/cm<sup>2</sup>** 4,190 psi  
 Pilot circuit ..... **3.2 MPa 33 kgf/cm<sup>2</sup>** 470 psi

Hydraulic cylinders:

(Number of cylinders – bore x stroke x rod diameter)

Boom .. **2–130 mm x 1334 mm x 90 mm** 5.1" x 52.5" x 3.5"  
 Arm ..... **1–135 mm x 1490 mm x 95 mm** 5.3" x 58.7" x 3.7"  
 Bucket.. **1–115 mm x 1120 mm x 80 mm** 4.5" x 44.1" x 3.2"



## DRIVES AND BRAKES

Steering control ..... Two levers with pedals  
 Drive method ..... Hydrostatic  
 Maximum drawbar pull ..... **202 kN 20570 kg** 45,349 lb  
 Gradeability ..... 70%, 35°  
 Maximum travel speed (auto-shift):  
 High ..... **5.5 km/h** 3.4 mph  
 Mid ..... **4.1 km/h** 2.5 mph  
 Low ..... **3.0 km/h** 1.9 mph  
 Service brake ..... Hydraulic lock  
 Parking brake ..... Mechanical disc brake



## SWING SYSTEM

Drive method ..... Hydrostatic  
 Swing reduction ..... Planetary gear  
 Swing circle lubrication ..... Grease-bathed  
 Service brake ..... Hydraulic lock  
 Holding brake/Swing lock ..... Mechanical disc brake  
 Swing speed ..... 12.4 rpm  
 Swing torque ..... **6900 kg•m** 49,907 ft lbs



## UNDERCARRIAGE

Centre frame ..... X-frame  
 Track frame ..... Box-section  
 Seal of track ..... Sealed track  
 Track adjuster ..... Hydraulic  
 Number of shoes (each side) ..... 49  
 Number of carrier rollers (each side) ..... 2  
 Number of track rollers (each side) ..... 9



## COOLANT & LUBRICANT CAPACITY (REFILLING)

Fuel tank ..... **400 ltr** 105.7 U.S. gal  
 Coolant ..... **30.7 ltr** 8.1 U.S. gal  
 Engine ..... **23.1 ltr** 6.1 U.S. gal  
 Final drive, each side ..... **5.0 ltr** 1.3 U.S. gal  
 Swing drive ..... **6.5 ltr** 1.7 U.S. gal  
 Hydraulic tank ..... **132 ltr** 34.9 U.S. gal  
 Hydraulic system ..... **234 ltr** 61.8 U.S. gal  
 DEF tank ..... **23.1 ltr** 6.1 U.S. gal



## OPERATING WEIGHT (APPROXIMATE)

Operating weight includes **5700 mm** one-piece HD boom, **2900 mm** HD arm, rated capacity of lubricants, coolant, full fuel tank, operator, standard equipment, KGA dual lock quick hitch, and SAE heaped **0.97 m<sup>3</sup>** bucket.

Triple-Grouser Shoes	Operating Weight		Ground Pressure	
	PC210-11	PC210LC-11	PC210-11	PC210LC-11
600 mm	22,640 kg	23,240 kg	0.52 kg/cm <sup>2</sup>	0.49 kg/cm <sup>2</sup>
700 mm	22,890 kg	23,510 kg	0.46 kg/cm <sup>2</sup>	0.42 kg/cm <sup>2</sup>
800 mm	23,180 kg	23,830 kg	0.41 kg/cm <sup>2</sup>	0.38 kg/cm <sup>2</sup>

## Component Weights

Arm including bucket cylinder and linkage  
**2900 mm** HD arm assembly ..... **1200 kg** 2,646 lb  
 One piece HD boom including arm cylinder  
**5700 mm** boom assembly ..... **1953 kg** 4,306 lb  
 Boom cylinders x 2 ..... **205 kg** 452 lb  
 Counterweight ..... **3830 kg** 8,443 lb



## DIMENSIONS

Arm Length	2900 mm	
	PC210-11	PC210LC-11
A Overall length	9705 mm	9705 mm
B Length on ground (transport)	5000 mm	5000 mm
C Overall height to top of boom*	2995 mm	2995 mm
D Overall width	2800 mm	2980 mm
E Overall height (to top of cab)*	3045 mm	3045 mm
F Overall height (to top of handrail)*	3135 mm	3135 mm
G Ground clearance, counterweight	1085 mm	1085 mm
H Ground clearance, minimum	440 mm	440 mm
I Tail swing radius	3020 mm	3020 mm
J Track length on ground	3275 mm	3655 mm
K Track length	4070 mm	4450 mm
L Track gauge	2200 mm	2380 mm
M Width of crawler	2800 mm	2980 mm
N Shoe width	600 mm	600 mm
O Grouser height	26 mm	26 mm
P Machine cab height	2250 mm	2250 mm
Q Machine height to top of engine cover	2765 mm	2765 mm
R Machine upper width	2850 mm	2850 mm
S Distance, swing centre to rear end	2990 mm	2990 mm

\* : Including grouser height

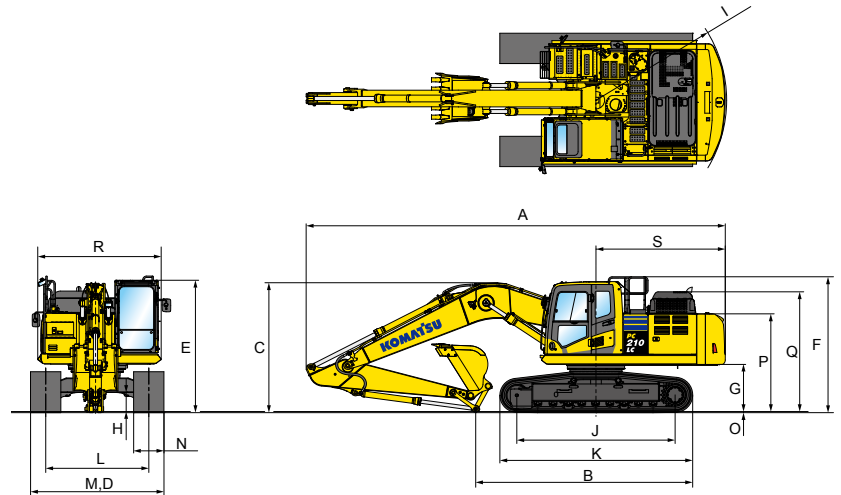

## WORKING RANGE

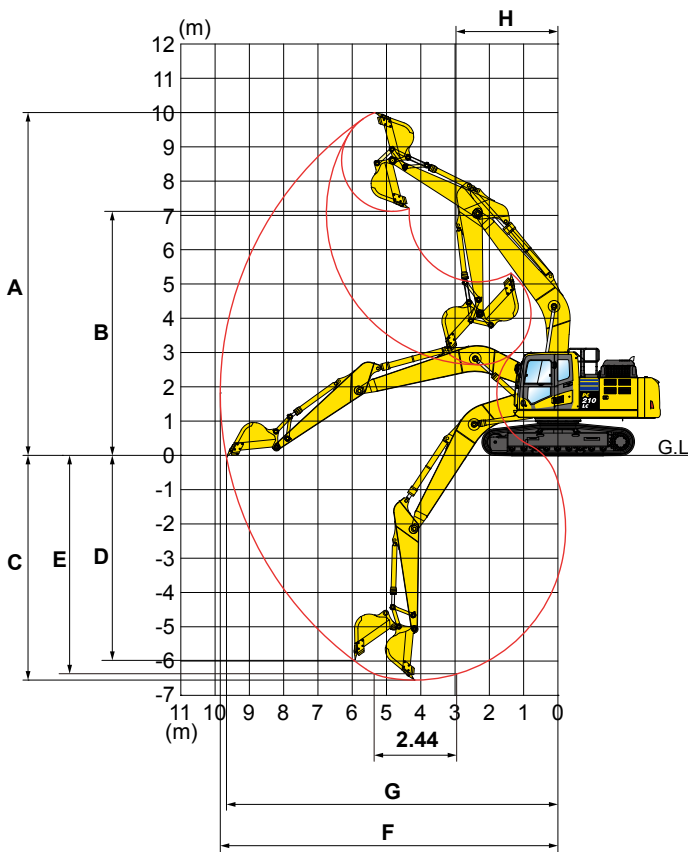

Arm Length	2900 mm	
A Max. digging height	10000 mm	
B Max. dumping height	7110 mm	
C Max. digging depth	6620 mm	
D Max. vertical wall digging depth	5980 mm	
E Max. digging depth for 8' level bottom	6370 mm	
F Max. digging reach	9875 mm	
G Max. digging reach at ground level	9700 mm	
H Min. swing radius	3040 mm	
SAE rating	Bucket digging force at power max.	132 kN 13500 kg
	Arm crowd force at power max.	103 kN 10500 kg
	ISO rating	Bucket digging force at power max.
	Arm crowd force at power max.	108 kN 11000 kg

# LIFT CAPACITIES



## LIFTING CAPACITY WITH LIFTING MODE

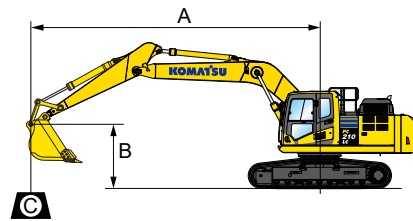

- A: Reach from swing centre
- B: Bucket hook height
- C: Lifting capacity
- Cf: Rating over front
- Cs: Rating over side
- ⊗: Rating at maximum reach

### Conditions:

- Boom length: 5700 mm
- Arm length: 2900 mm
- Shoes: 600 mm triple grouser
- Bucket: 650 kg

### PC210-11

Unit: kg

B	A		1.5 m		3.0 m		4.5 m		6.0 m		7.5 m		⊗ MAX	
	Cf	Cs	Cf	Cs	Cf	Cs	Cf	Cs	Cf	Cs	Cf	Cs	Cf	Cs
7.5 m									*4050	*4050			*2850	*2850
6.0 m									*4250	*4250	*3050	*3050	*2750	*2750
4.5 m							*5500	*5500	*4850	4550	4500	3050	*2750	2600
3.0 m			*11550	*11550	*7700	6800	*5850	4250	4400	2900	*2900	2300		
1.5 m			*6800	*6800	9600	6250	6100	4000	4250	2750	*3200	2200		
0 m			*5200	*5200	9350	5850	5850	3800	4100	2650	3450	2250		
-1.5 m	*5150	*5150	*9300	*9300	9150	5750	5750	3700	4050	2600	3750	2450		
-3.0 m	*9750	*9750	*14800	11500	9250	5800	5750	3700			4500	2900		
-4.5 m			*12900	*11550	*9050	6000					6400	4150		

\*Load is limited by hydraulic capacity rather than tipping. Ratings are based on SAE standard No. J1097. Rated loads do not exceed 87% of hydraulic lift capacity or 75% of tipping load.

### PC210LC-11

Unit: kg

B	A		1.5 m		3.0 m		4.5 m		6.0 m		7.5 m		⊗ MAX	
	Cf	Cs	Cf	Cs	Cf	Cs	Cf	Cs	Cf	Cs	Cf	Cs	Cf	Cs
7.5 m									*4050	*4050			*2850	*2850
6.0 m									*4250	*4250	*3050	*3050	*2750	*2750
4.5 m							*5500	*5500	*4850	*4850	*4550	3450	*2750	*2750
3.0 m			*11550	*11550	*7700	7600	*5850	4850	*5050	3350	*2900	2650		
1.5 m			*6800	*6800	*9750	7100	*6900	4550	5100	3200	*3200	2550		
0 m			*5200	*5200	*10750	6750	7150	4350	5000	3050	*3700	2600		
-1.5 m	*5150	*5150	*9300	*9300	*10900	6600	7000	4250	4950	3000	*4600	2800		
-3.0 m	*9750	*9750	*14800	13400	*10500	6650	7050	4250			5500	3350		
-4.5 m			*12900	*12900	*9050	6850					*6650	4750		

\*Load is limited by hydraulic capacity rather than tipping. Ratings are based on SAE standard No. J1097. Rated loads do not exceed 87% of hydraulic lift capacity or 75% of tipping load.



**STANDARD EQUIPMENT**

- 3 speed travel with auto shift
- Alternator, 90 A, 24 V
- AM/FM radio
- Arm, 2900 mm
- Auto idle
- Auto idle shut down
- Automatic air conditioner, large capacity
- Automatic engine warm-up system
- Auxiliary input (3.5 mm jack)
- Batteries, large capacity
- Battery isolation switch, lockable
- Boom, 5700 mm
- Boom and arm burst valve protection
- Bump rails
- Cab guards
  - Lower front window guard
  - Integrated top guard, OPG Level 1
  - Bolt on top guard, OPG Level 2
- Carrier rollers, (2 each side)
- Converter, (2) x 12 V
- Counterweight, 3830 kg
- Dry type air cleaner, double element
- Dual flow hammer piping
- Electric horn
- Emergency stops (3)
- EMMS monitoring system
- Engine, Komatsu SAA6D107E-3
- Fan guard structure
- Fuel system pre-filter 10 micron
- High back air suspension seat, with heat
- High pressure in-line hydraulic filters
- Hydraulic track adjusters
- Hydraumind closed centre load sensing system
- KOMTRAX Level 5.0
- Large LCD colour monitor, high resolution
- Level indicator
- Lock lever
- Lock lever, auto-lock
- Mirrors (LH, RH & sidewise)
- Operator identification system
- Overload alarm
- Power maximising system
- PPC hydraulic control system
- Proportional control handles
- Provision for tilt circuit, including valve
- Pump/engine room partition cover
- Quick hitch piping with safety switch and alarm
- Radiator and oil cooler dustproof net
- Rear reflectors
- Rearview monitoring system (1 camera)
- Revolving frame undercovers
- ROPS cab (ISO 12117-2) with vandal guard provisions
- Rotating beacon with guard
- Seat belt indicator
- Seat belt, retractable, 78 mm
- Secondary engine shutdown switch
- Side by side coolers
- Slip resistant foot plates
- Starter motor, 5.5 kW/24 V x 1
- Suction fan
- Thermal and fan guards
- Track roller guides, 2 each side
- Track rollers, 9 each side
- Track frame swivel guard
- Track shoes, triple grouser, 600 mm
- Travel alarm
- Working lights
  - 1 x boom
  - 1 x RH
  - 3 x cab
  - 1 x counterweight
- Working mode selection system



**OPTIONAL EQUIPMENT**

- Autogrease system
- Battery isolation switch, dual pole, lockable
- Belly plates, 8 mm
- Cab guard
  - Full front guard, OPG Level 2
- Cab vandal guard set
- Canvas seat cover
- Fire extinguisher, 1.5 kg
- Fire extinguisher, 4.5 kg
- Fire extinguisher, 9 kg
- Fuel cap vandal guard
- Jump start receptacle
- Radio, multimedia system
- Radio, UHF
- Starter circuit isolation, lockable
- Track roller guards, full length
- Track shoes, triple grouser, 700 mm
- Track shoes, triple grouser, 800 mm
- Turbo timer
- Window tinting



**ATTACHMENT OPTIONS**

- Bucket, general purpose, KGA 600 mm, 0.39 m<sup>3</sup>
- Bucket, general purpose, KGA 900 mm, 0.68 m<sup>3</sup>
- Bucket, general purpose, KGA 1200 mm, 0.97 m<sup>3</sup>
- Bucket, slope finishing, KGA 2000 mm, 1.10 m<sup>3</sup>
- Quick hitch, KGA, dual lock
- Quick hitch, KGA, dual lock, tilting
- Ripper, KGA, single tyne

**COMING SOON**

**KOMATSU  
JMHB230V-1  
Hydraulic  
Breaker**



Model Type		JMHB230V-1
Working weight	kg	1,450
Oil flow (min - max)	ℓ /min	120 - 170
Operating pressure (max)	MPa	135
Impact rate	bpm	285 - 1,050
Chisel diameter	mm	122
Acceptable back pressure	bar	8
Base machine (min - max)	Ton	18 - 30

For a complete list of available attachments, please contact your local Komatsu representative.

