

# KOMATSU

## PC138US-11

Non-Tier 4



Photos may include optional equipment.

### Hydraulic excavator

**Engine power**

72 kW / 97.2 HP @ 2050 rpm

**Operating weight**

15,492 - 15,852 kg

**Bucket capacity**

0.21 - 0.53 m<sup>3</sup>

## Walk-around

A powerful **Komatsu SAA4D95LE-7 engine** provides a net output of 72.5 kW **97.2 HP**.

**Variable Flow Turbocharger** improves engine response and provides optimum air flow under all speed and load conditions.

**Enhanced working modes** are designed to match engine speed, pump delivery, and system pressure to the application.

**Komatsu's Closed-center Load Sensing System (CLSS)** provides quick response and smooth operation to maximise productivity.

**Temperature controlled fan clutch** helps improve fuel efficiency and lower sound levels.

The **KOMTRAX®** telematics system is standard on Komatsu equipment with no subscription-fee's throughout the life of the machine. Using the latest wireless technology, **KOMTRAX®** transmits valuable information such as location, utilisation, and maintenance records to a PC or smartphone app. Custom machine reports are provided for identifying machine efficiency and operating trends. **KOMTRAX®** also provides advanced machine troubleshooting capabilities by continuously monitoring machine health.

### **Large LCD color monitor panel:**

- 7" high resolution screen
- Provides "Ecology-Guidance" for fuel efficient operation
- Enhanced attachment control

### **Rearview monitoring system (standard)**

**Equipment Management Monitoring System (EMMS)** continuously monitors machine operation and vital systems to identify machine issues and assist with troubleshooting.

### **Enhanced working environment**

- Integrated ROPS cab design (ISO 12117-2)
- Cab meets ISO Level 1 Operator Protective Guard (OPG) top guard (ISO 10262)
- AUX jack and (2) 12V outlets

### **Komatsu designed and manufactured components**

**Wide access service doors** provide easy access for ground level maintenance.

**New quick return arm valve** improves arm cylinder hydraulic flow for faster arm out speed and performance.

**Handrails (standard)** provides convenient access to the upper structure.

**Komatsu Auto Idle Shutdown** helps reduce non-productive engine idle time and reduces operating costs.

**Lockable single-pole battery isolation switch** allows a technician to disconnect the power supply before servicing the machine.

**Operational Identification System** can track machine operation for up to 100 hours.



### Fuel Economy & Tight Tail Performance

New hydraulic control technology improves operational efficiency and lowers fuel consumption.

Rounded cab profile with a sliding door allows the cab to swing within the same radius as the counterweight for true tight tail performance.



## Performance Features

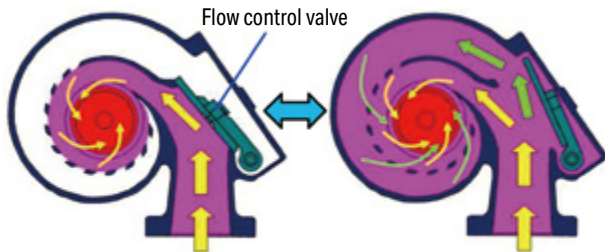

### Variable flow turbocharger

A variable flow turbocharger features simple and reliable technology that varies the intake air-flow. The Exhaust turbine speed is controlled by a flow control valve that optimises air volume to the engine combustion chamber under all engine speed and load conditions. The result is cleaner exhaust gas while maintaining power and performance.

### Advanced Electronic control system

The electronic control system performs high-speed processing of all signals from sensors installed in the machine providing total control of equipment in all operating conditions of use. Engine condition information is displayed via an onboard network to the monitor inside the cab, providing necessary information to the operator. Additionally, managing the information via KOMTRAX helps customers keep up with required maintenance.

### High Pressure Common Rail (HPCR) fuel injection system

High pressure fuel injection with computerised control attains close to complete combustion reducing Particulate Matter (PM) emissions. While this technology is already used in current engines, the new system uses a higher-pressure injection, thereby reducing both PM emissions and fuel consumption at all engine load conditions.

### Komatsu Auto Idle Shutdown

Komatsu auto idle shutdown automatically shuts the engine down after idling for a set period of time to reduce unnecessary fuel consumption and exhaust emissions.

### Viscous fan clutch

Reduces engine loads at lower operating temperatures.

### High Breakout Forces

The PC138USLC-11 provides high breakout forces for operation in difficult digging conditions.

### Fine Controllability

Proportional Pilot Controls (PPC) allow the operator finite control and feed back with minimal effort for comfort and efficiency.

### High Mobility

The PC138USLC-11 is equipped with two speed travel and automatic shift with a high drawbar pull for work in wet or muddy conditions and blade applications.

### Arm quick return valve

When extended, the arm's quick return valve directs additional oil through a second line directly back to tank which reduces back pressure. Reduces fuel consumption and improves efficiency.



# PC138US-11

## Efficient Hydraulic System

The PC138USLC-11 uses a Closed-centre Load Sensing System (CLSS) that improves fuel efficiency and provides quick response to the operator's demands. The control system matches engine and hydraulic demand at the most efficient point under any load condition. There have also been improvements in the main valve and hydraulic circuit to reduce hydraulic loss, resulting in higher efficiency and lower fuel consumption.

## Large Displacement High Efficiency Pump

Large displacement hydraulic implement pumps provide high flow output at lower engine RPM as well as operation at the most efficient engine speed.



## Working Mode Selection

The PC138USLC-11 excavator is equipped with six working modes (P, E, L, B, ATT/P and ATT/E). Each mode is designed to match engine speed, pump flow, and system pressure to the application. The PC138USLC-11 features an attachment mode (ATT/E) that allows operators to run attachments while in Economy mode.

Working Mode	Application	Advantage
<b>P</b>	Power mode	<ul style="list-style-type: none"> <li>Maximum production/power</li> <li>Fast cycle times</li> </ul>
<b>E</b>	Economy mode	<ul style="list-style-type: none"> <li>Good cycle times</li> <li>Better fuel economy</li> </ul>
<b>L</b>	Lifting mode	<ul style="list-style-type: none"> <li>Increases hydraulic pressure</li> </ul>
<b>B</b>	Breaker mode	<ul style="list-style-type: none"> <li>Optimum engine rpm, hydraulic flow</li> </ul>
<b>ATT/P</b>	Attachment Power mode	<ul style="list-style-type: none"> <li>Optimum engine rpm, hydraulic flow, 2-way</li> <li>Power mode</li> </ul>
<b>ATT/E</b>	Attachment Economy mode	<ul style="list-style-type: none"> <li>Optimum engine rpm, hydraulic flow, 2-way</li> <li>Economy mode</li> </ul>

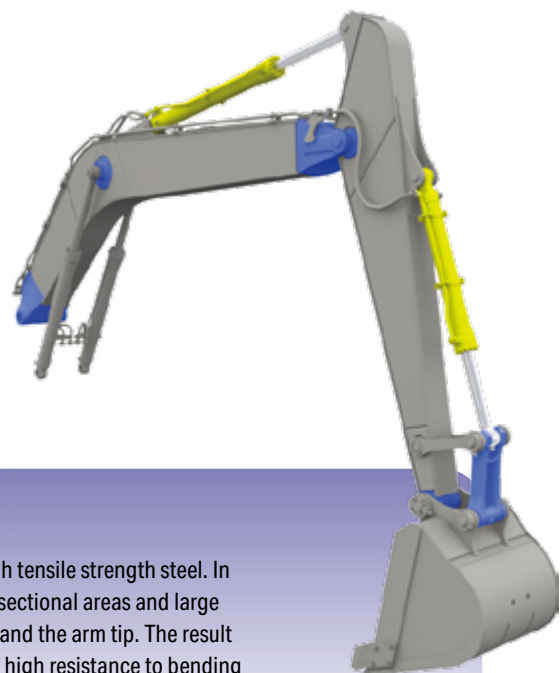
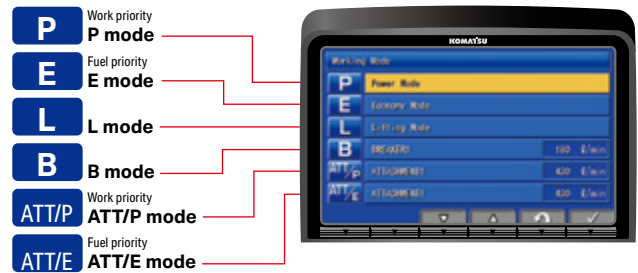

## High Rigidity Work Equipment

Booms and arms are constructed with thick plates of high tensile strength steel. In addition, these structures are designed with large cross sectional areas and large one piece steel castings in the boom foot, the boom tip, and the arm tip. The result is work equipment that exhibits long term durability and high resistance to bending and torsional stress.

# Operation Features

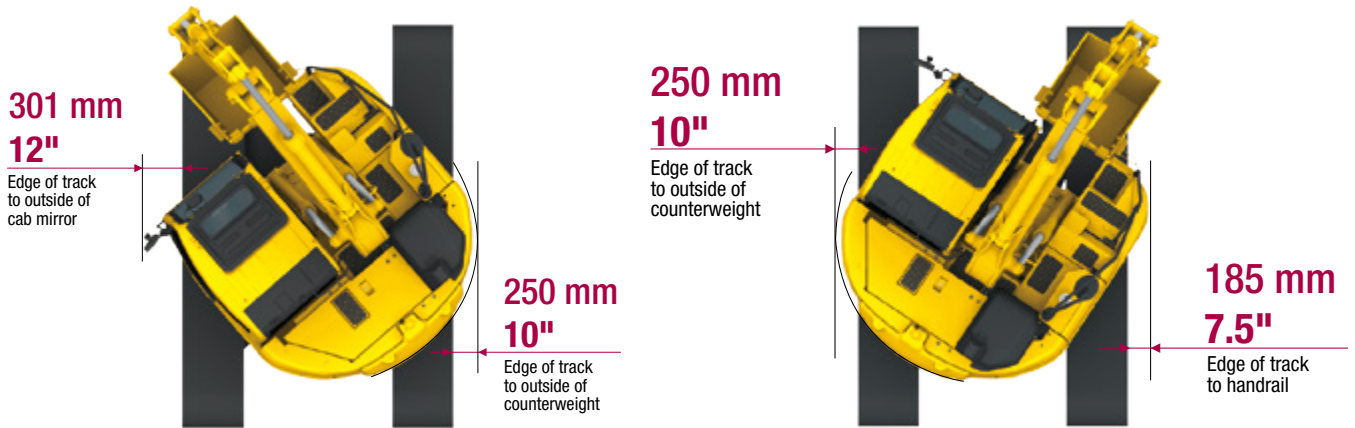

Shoe width is 600 mm 24".

## Short Implement Swing Radius

A higher boom raise angle than a standard excavator reduces the minimum front implement swing radius down to 1980mm **6'6"**. The result is greater front swing clearance when space is limited.

## Short Tail Swing Radius

1545 mm **5'1"** short tail swing radius of the PC138USLC-11 allows the machine to work in more confined areas than a conventional machine.

## Ideal for Confined Applications

The PC138USLC-11 is an ideal machine for applications such as road work, underground utilities or other applications where a conventional excavator will not fit. The contoured cab design and convex sliding door allow the cab to swing within the same radius as the counterweight. Trucks can be positioned closer to the machine when working within one lane of traffic, improving operator confidence and job efficiency.



# Working Environment



## Comfortable Working Space

### Large cab with wide front view and foot space

A large operator cab with rounded corner provides an overall cab size similar to a standard excavator cab even though this machine has an extra small swing radius. A sliding door enables easy access especially in confined work areas. Additional operator comfort is provided with a fully adjustable suspension seat.

### Automatic Air Conditioner

The automatic air conditioner allows the operator to easily and precisely set the cab atmosphere using the large LCD color monitor panel. The bi-level control function improves air flow and keeps the inside of the cab comfortable throughout the year.



### Pressurised cab

### Low Vibration with cab damper mounting

### Low cab noise

### Auxiliary input jack

Connecting an auxiliary device such as an MP3 player to the auxiliary input enables the operator to hear the sound throughout the stereo speakers installed in the cab.



## Standard Equipment

### Pull-up front window



### Remote intermittent wiper with windshield washer



### AM/FM radio



### Cup holder



### ISO Level 2 OPG



### Defroster (conforms to the ISO standard)



### Literature box



### Emergency stop button





### New Monitor Panel Interface Design

An updated large high resolution LCD color monitor enables accurate and smooth work. The interface has been redesigned to display key machine information in a new user friendly interface. The interface has a function that enables the main screen mode to be changed to provide the optimum screen information for the operator.

#### Indicators

- |                                    |                            |
|------------------------------------|----------------------------|
| 1 Auto-decelerator                 | 8 Fuel gauge               |
| 2 Working mode                     | 9 Camera direction display |
| 3 Travel speed                     | 10 Service meter, clock    |
| 4 Ecology gauge                    | 11 Fuel consumption gauge  |
| 5 Camera display                   | 12 Guidance icon           |
| 6 Engine coolant temperature gauge | 13 Function switches       |
| 7 Hydraulic oil temperature gauge  |                            |

#### Basic operation switches

- |                         |                         |
|-------------------------|-------------------------|
| 1 Auto-decelerator      | 4 Buzzer cancel         |
| 2 Working mode selector | 5 Wiper                 |
| 3 Travel speed selector | 6 Window washer         |
|                         | 7 Auto climate controls |

### Switchable display modes

The updated monitor screen display mode can be easily switched by pressing the F3 key.



Default Display

Full Rear Camera Display

### Visual user menu

Pressing the F6 key on the main screen displays the user menu screen. The menus are grouped for each function, and use easy-to-understand icons which enable the machine to be operated easily.



- |                                       |                    |
|---------------------------------------|--------------------|
| 1 Energy saving guidance              | 2 Machine settings |
| 3 Aftertreatment device regeneration* | 4 Maintenance      |
| 5 Monitor Setting                     | 6 Message check    |

# PC138US-11

## Support Efficiency Improvement

### Ecology guidance

While the machine is operating, Ecology guidance information can be displayed on the monitor screen to provide fuel saving advice in real time.

### Ecology gauge & fuel consumption gauge

The monitor screen includes an Ecology gauge and a fuel consumption gauge which is displayed continuously. The operator can set a target value.



Ecology gauge Ecology guidance Fuel consumption gauge

## Operator Identification Function

An operator identification (ID) code can be set for each operator and used to manage operation information of individual machines using KOMTRAX data. Data sent from KOMTRAX can be used to analyse operation status by operator, application etc. as well as by machine.



## Operation records, fuel consumption history, and Ecology guidance records

The Ecology guidance menu enables the operator to check the operation records, fuel consumption history and Ecology guidance records.



Ecology guidance record



Operation record



Fuel consumption history

# Maintenance Features

## Standard high-efficiency fuel filter and fuel pre-filter with water separator

A high-efficiency fuel filter and a fuel pre-filter with water separator increase reliability. The fuel pre-filter is equipped with a priming pump.



High efficiency fuel filter

Fuel pre-filter (With water separator)

## Easy access to engine oil filter, engine main fuel filter and fuel drain valve

The engine oil filter, engine main fuel filter and fuel drain valve are remote mounted to improve accessibility.

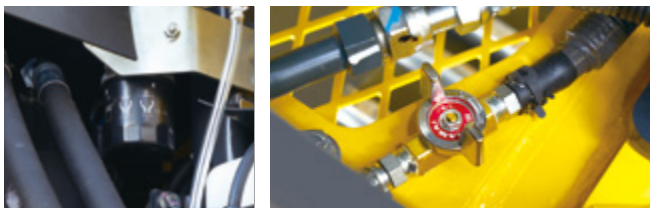

Engine oil filter

Fuel drain valve

## Battery isolation switch

A standard battery isolation switch allows a technician to disconnect the power supply and lock out before servicing the machine.

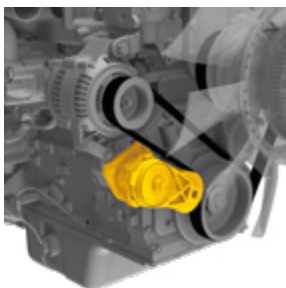

## Fan belt auto-tensioner

For maintenance free fan belt tension adjustment.

## Long-life oil, filter

Engine oil & engine oil filter	every 500 hours
Hydraulic oil	every 5000 hours
Hydraulic oil filter	every 1000 hours



Hydraulic oil filter (Ecology white plus element)

## Attachment circuit filter

An easy access filter protects the hydraulic system from attachment contaminants (included with factory + 1 attachment piping).



## A/C filter

The A/C, cab air filter is serviced without the use of tools.

## Side-by-side cooling

The radiator and oil cooler are side-by-side modules which simplifies cleaning, removal and installation. The addition of screens help keep the cooler cores clean and free of debris.



## Large tool box

A tool box large enough for storing a grease gun is provided as standard.



## Easy-to-clean cab floor mat

The PC138USLC-11's surface grooves run parallel to the operator and has a flanged edge combined with drainage holes to allow water run off when cleaning the cab.



# PC138US-11



## "Maintenance time caution lamp" display

When the remaining time to maintenance becomes less than 30 hours\* a maintenance time monitor appears.

\* The settings can be changed to between 10 and 200 hours.



Maintenance screen

# General Features

## ROPS Cab (ISO 12117-2)

The machine is equipped with a ROPS cab that conforms to ISO 12117-2 for excavators as standard equipment. It also satisfies the requirements for Level 1 Operator Protective Guard (OPG) and top guard (ISO 10262).



## Rear View Monitoring System

An updated rear view monitoring system display has a camera image that is continuously displayed together with the gauges and important vehicle information. This enables the operator to carry out work while easily checking the surrounding area.



## Low Vibration with Viscous Cab Mounts

The PC138USLC-11 uses viscous mounts for the cab that incorporate a longer stroke and the addition of a spring. The cab damper mounting combined with a high rigidity deck reduces vibration at the operator's seat.

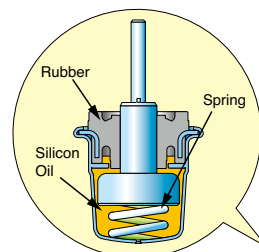

- Lock lever
- Seat belt, retractable
- Tempered & tinted glass
- Large mirrors
- Slip-resistant plates
- Thermal and fan guards
- Pump/engine room partition
- Travel alarm
- Large cab entrance step
- Handrails
- Sliding door



**Secondary engine shut down switch** at base of seat to shutdown the engine.



## KALSS Australian Standard Specification



**Rotating Amber Beacon**  
Fitted with factory guard.



**Level Indicator, Overload Alarm & Anti-Burst Valves**  
Enable safety and compliance when lifting suspended loads



**Additional Lighting**  
Extra lighting on cab for improved visibility



**Proportional Hand Controls**  
Enables proportional hand control of attachment speed



**Lower Front Window Guard**  
Protects cabin windscreen against rocks and debris.



**Battery Isolation**  
Single pole, lockable Boschtype battery isolation.



**E-Stops**  
Allow compliance to site safety requirements.



**Bolt-on Top Guard**  
OPG level 2 (ISO 10262) for falling object protection.

**Reinforced Arm and Link**  
Reinforced steel plate to provide additional protection of arm structure and heavy duty links.

**Factory Fitted Quick Hitch and Hammer Piping**  
Enables use with a greater variety of attachments. Also fitted with provision for tilt circuit including valve.

**Heavy Duty Revolving Frame Under Covers**  
Protects and prevents ingress of material into engine bay.

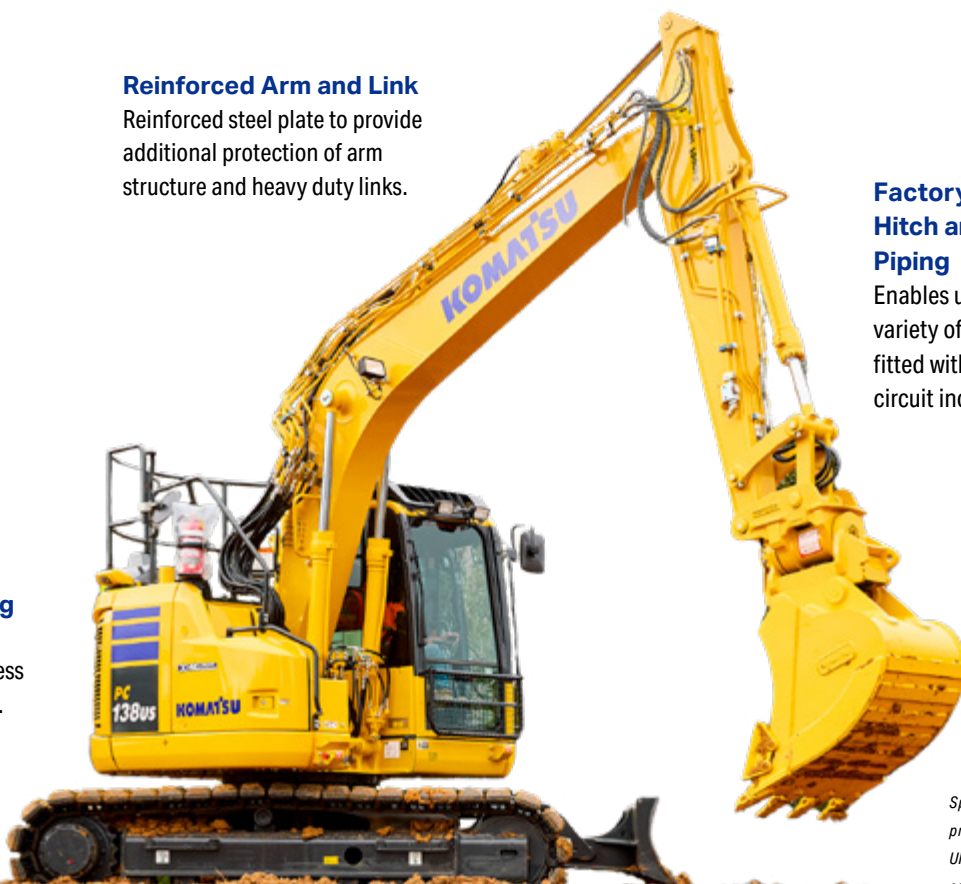

*Specification also includes factory fitted provisions for fire extinguisher, turbo timer, UHF and vandal covers to reduce lead times and costs. Photos may include optional equipment.*

# Specifications

## Engine

Model.....	Komatsu SAA4D95LE-7*
Type.....	Water-cooled, 4-cycle, direct injection
Aspiration.....	Variable flow, turbocharged, air-to-air aftercooled
Number of cylinders.....	4
Bore.....	95 mm   3.74"
Stroke.....	115 mm   4.53"
Piston displacement.....	3.26 ltr   199 in <sup>3</sup>
Horsepower:	
SAE J1995.....	Gross 72.6 kW / 97.3 HP
ISO 9249 / SAE J1349.....	Net 72.5 kW / 97.2 HP
Rated rpm.....	2050
Fan drive method for radiator cooling.....	Mechanical with viscous clutch
Governor.....	All-speed control, electronic

\*Non-Tier 4 engine does not comply with US EPA Tier 4 Final regulation

## Hydraulics

Type.....	HydrauMind (Hydraulic Mechanical Intelligence) system, closed-center system with load sensing valve and pressure compensated valve
Number of selectable working modes.....	6
Main pump:	
Type.....	Variable capacity piston type
Pump for.....	Boom, arm, bucket, swing, and travel circuits
Maximum flow.....	242 ltr/min   64 gal/min
Hydraulic motors:	
Travel.....	2 x piston motor with parking brake
Swing.....	1 x piston motor with swing holding brake
Relief valve setting:	
Implement circuits.....	34.8 MPa 355 kgf/cm <sup>2</sup> 5,050 psi
Travel circuit.....	34.8 MPa 355 kgf/cm <sup>2</sup> 5,050 psi
Swing circuit.....	29.2 MPa 298 kgf/cm <sup>2</sup> 4,240 psi
Pilot circuit.....	3.2 MPa 33 kgf/cm <sup>2</sup> 470 psi
Hydraulic cylinders:	
(Number of cylinders – bore x stroke x rod diameter)	
Boom.....	2-105 mm x 1055 mm x 70 mm 4.1" x 41.5" x 2.76"
Arm.....	1-110 mm x 1175 mm x 75 mm 4.3" x 46.3" x 2.95"
Bucket.....	1-95 mm x 885 mm x 65 mm 3.7" x 34.8" x 2.56"

## Drives and brakes

Steering control.....	Two levers with pedals
Drive method.....	Fully hydrostatic
Maximum drawbar pull.....	123 kN 12500 kgf   27,560 lbf
Gradeability.....	70%, 35°
Maximum travel speed:	
(Auto-shift) High.....	5.1 km/h   3.2 mph
Low.....	2.9 km/h   1.8 mph
Service brake.....	Hydraulic lock
Parking brake.....	Wet, multiple-disc

## Swing System

Driven by.....	Hydraulic motor
Swing reduction.....	Planetary gear
Swing circle lubrication.....	Grease-bathed
Service brake.....	Hydraulic lock
Swing lock.....	Wet, multiple-disc brake
Swing speed.....	11.0 rpm
Swing torque.....	2991 kg.m   21,627 ft lbs

## Undercarriage

Center frame.....	X-frame leg
Track frame.....	Box-section
Track type.....	Sealed track
Track adjuster.....	Hydraulic
Number of shoes (each side).....	46
Number of carrier rollers (each side).....	2
Number of track rollers (each side).....	8

## Coolant & Lubricant Capacity (Refilling)

Fuel tank.....	200 ltr   52.8 U.S. gal
Coolant.....	17.7 ltr   4.6 U.S. gal
Engine.....	11.5 ltr   3.0 U.S. gal
Final drive, each side.....	2.1 ltr   .55 U.S. gal
Swing drive.....	2.5 ltr   0.7 U.S. gal
Hydraulic tank.....	69.0 ltr   18.2 U.S. gal

## Operating Weight (Approximate)

Operating weight includes 4600 mm one-piece boom, 2500 mm arm, rated capacity of lubricants, coolant, full fuel tank, operator, standard equipment, KGA dual lock quick hitch, and SAE heaped 0.53 m<sup>3</sup> bucket.

Shoes	Operating Weight	Ground Pressure
Steel city pattern 500 mm	15,630 kg	0.47 kg/cm <sup>2</sup>
Rubber road liner 500 mm	15,710 kg	0.47 kg/cm <sup>2</sup>
Triple-grouser 500 mm	15,680 kg	0.47 kg/cm <sup>2</sup>
Triple-grouser 600 mm	16,030 kg	0.40 kg/cm <sup>2</sup>

## Component Weights

Arm including bucket cylinder and linkage		
2100 mm arm assembly.....	556 kg	1,226 lb
2500 mm arm assembly.....	657 kg	1,448 lb
3000 mm arm assembly.....	705 kg	1,554 lb
One piece boom including arm cylinder		
4600 mm boom assembly.....	962 kg	2,118 lb
Boom cylinders x2.....	105 kg	231 lb
Counterweight.....	2,640 kg	5,820 lb
Blade including blade cylinders.....	800 kg	1,764 lb

# Specifications

## Dimensions

	Arm Length	2500 mm	2100 mm	3000 mm
A	Overall length	7385 mm	7275 mm	7160 mm
B	Overall height (to top of boom)*	2850 mm	2805 mm	2310 mm
C	Length on ground (transport)	4400 mm	4640 mm	4290 mm
D	Overall width	2490 mm		
E	Overall height (to top of cab)*	2815 mm		
F	Ground clearance, counterweight	900 mm		
G	Ground clearance, minimum	395 mm		
H	Tail swing radius	1480 mm		
I	Track length on ground	3140 mm		
J	Track length	3870 mm		
K	Track gauge	1990 mm		
L	Width of crawler	2490 mm		
M	Shoe width	500 mm		
N	Grouser height	20 mm		
O	Machine height to top of counterweight	2140 mm		
P	Machine upper width	2490 mm		
Q	Distance, swing center to rear end	1480 mm		

\* : Including grouser height

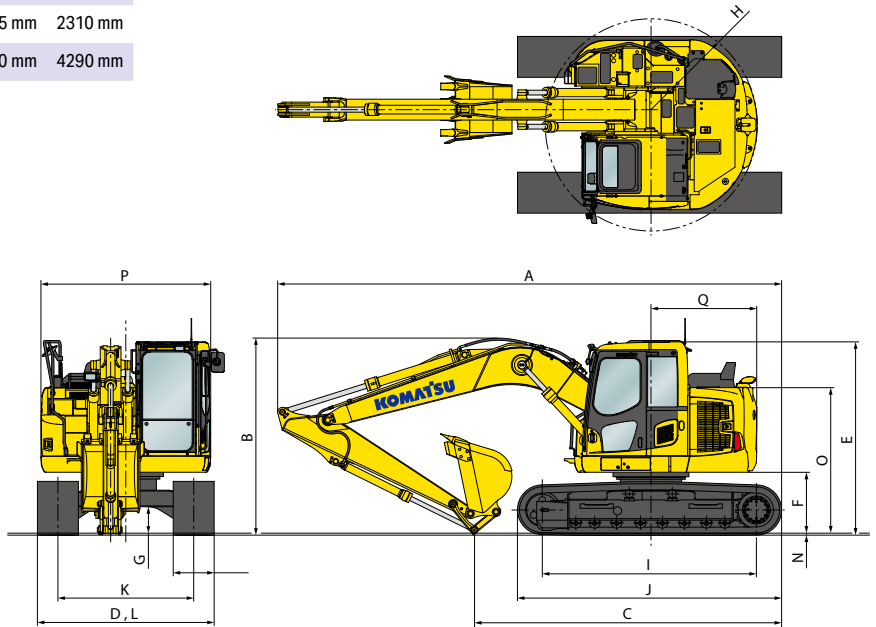

## Working Range

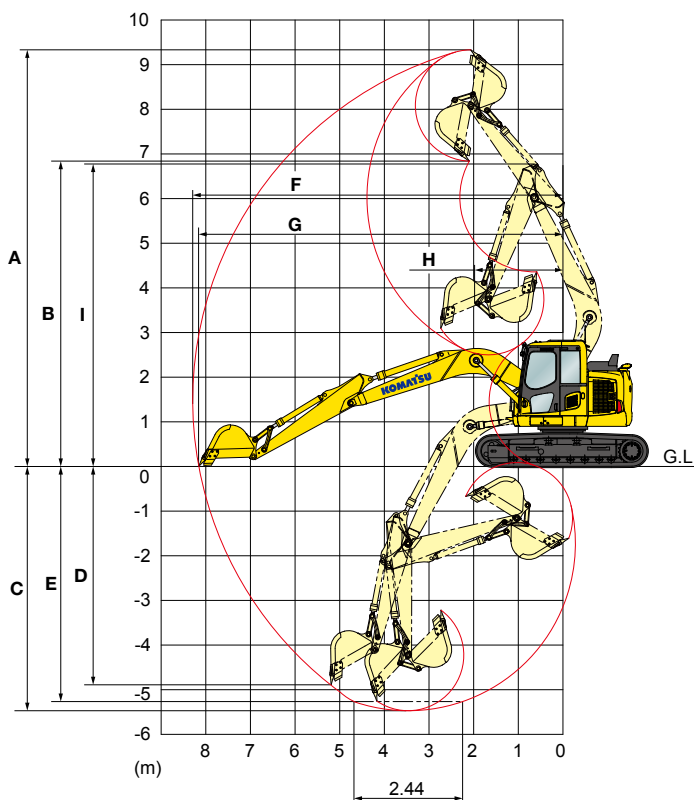

	Arm Length	2500 mm	2100mm	3000 mm
A	Max. digging height	9340 mm	9020 mm	9700 mm
B	Max. dumping height	6840 mm	6525 mm	7350 mm
C	Max. digging depth	5480 mm	5070 mm	5900 mm
D	Max. vertical wall digging depth	4900 mm	4490 mm	5340 mm
E	Max. digging depth for 8' level bottom	5265 mm	4835 mm	5715 mm
F	Max. digging reach	8300 mm	7930 mm	8720 mm
G	Max. digging reach at ground level	8180 mm	7805 mm	8600 mm
H	Min. swing radius	1980 mm	1845 mm	2264 mm
I	Max. height at min. swing radius	6770 mm	6770 mm	6770 mm
SAE rating	Bucket digging force	81.4 kN 8300 kg	81 kN 8250 kg	78.0 kN 7950 kg
	Arm crowd force	60.8 kN 6200 kgf	66 kN 6730 kgf	54.4 kN 5550 kgf
ISO rating	Bucket digging force	93.2 kN 9500 kg	93 kN 9480 kg	88.3 kN 9000 kg
	Arm crowd force	61.8 kN 6300 kgf	70 kN 7130 kgf	55.9 kN 5700 kgf

## Lifting Capacity with Lifting Mode

- A: Reach from swing center
- B: Bucket hook height
- C: Lifting capacity
- Cf: Rating over front
- Cs: Rating over side
- ☉: Rating at maximum reach

### Conditions:

- Boom length: 4600 mm
- Arm length: 2500 mm
- Shoes: 500 mm steel city pattern
- Bucket: 400 kg

Unit: kg

B \ A	3.0 m		4.6 m		6.1 m		☉ MAX	
	Cf	Cs	Cf	Cs	Cf	Cs	Cf	Cs
6.1 m			* 2960	* 2960			* 1610	* 1610
3.0 m	* 6010	6010	* 4210	3400	3350	2110	* 1490	1490
0 m	* 5800	5800	5010	3020	3140	1930	* 1850	1500
-3.0 m	* 7270	5890	4800	2950			3340	2130

\*Load is limited by hydraulic capacity rather than tipping. Ratings are based on SAE standard No. J1097. Rated loads do not exceed 87% of hydraulic lift capacity or 75% of tipping load.

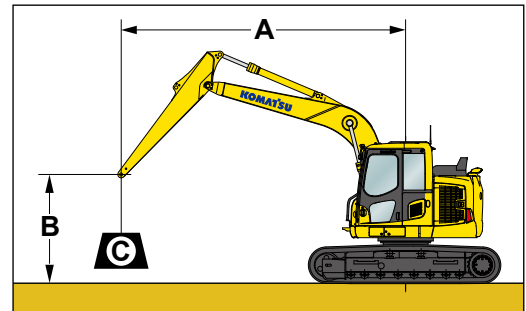

## Standard Equipment

- 2 speed travel with auto shift
- Alternator, 60 Ampere, 24V
- AM/FM radio
- Arm, 2500 mm
- Automatic air conditioner
- Automatic engine warm-up system
- Auto idle
- Auto idle shut down
- Auxiliary input (3.5mm jack)
- Batteries, large capacity (2 x 12V)
- Battery isolation switch, lockable, dual pole
- Blade assembly
- Boom, 4600 mm
- Boom and arm burst valve protection
- Cab guards
  - Lower front window guard
  - Integrated top guard, OPG Level 1
  - Bolt on top guard, OPG Level 2
- Canvas seat cover
- Carrier rollers, (2 each side)
- Converter, (2) x 12V
- Counterweight, 2640 kg
- Dry type air cleaner, double element
- Dual flow hammer piping
- Electric horn
- Emergency stops (3)
- Engine, Komatsu SAA4D95LE-7
- EMMS monitoring system
- Engine overheat prevention system
- Fan guard structure
- Fire extinguisher, 1.5 kg
- Fuel system pre-filter 10 micron
- Grease sealed track chain
- High back air suspension seat, with heat
- High pressure in-line hydraulic filters
- Hydraumind closed centre load sensing system
- KOMTRAX Level 5.0
- Large LCD colour monitor, high resolution
- Level indicator
- Lock lever
- Lock lever, auto lock
- Mirrors (LH & sidewise)
- Operator identification system
- Overload alarm
- PPC hydraulic control system
- Proportional control handles
- Provision for tilt circuit, including valve
- Pump/engine room partition cover
- Radio, multimedia system
- Radiator and oil cooler dustproof net
- Rear reflectors
- Rearview monitoring system (1 camera)
- Revolving frame undercovers, heavy duty
- ROPS cab (ISO 12117-2) with vandal guard provisions
- Rotating beacon with guard
- Seat belt indicator
- Seat belt, retractable, 78mm
- Secondary engine shutdown switch
- Slip resistant foot plates
- Starter circuit isolation, lockable
- Starter motor, 4.5 kW/24V x 1
- Suction fan with viscous clutch
- Thermal and fan guards
- Track frame swivel guard
- Track roller guides, 1 each side
- Track rollers, 7 each side
- Track shoes, steel city pattern, 500 mm
- Travel alarm
- Turbo timer
- Quick hitch piping with safety switch and alarm
- Window tinting
- Working lights
  - 1 x boom
  - 2 x cab
- Working mode selection system

## Optional Equipment

- Additional counterweight, 500 kg
- Arm, 2100 mm
- Arm, 3000 mm
- Autogrease system
- Cab vandal guard set
- 3DMG Factory Fit Upgrade Kit
- Fire extinguisher, 4.5 kg
- Fire extinguisher, 9 kg
- Fuel cap vandal guard
- Jump start receptacle
- Komvision
- Radio, UHF
- Track shoes, rubber road liner, 500 mm
- Track shoes, triple grouser, 500 mm
- Track shoes, triple grouser, 600 mm
- Long Carriage (LC)

## Attachment Options

- Bucket, General Purpose 450mm / 0.21m<sup>3</sup> with Kprime P015 x3 KGA (MD 1.6)
- Bucket, General Purpose 450mm / 0.21m<sup>3</sup> with XS15 x3 KGA (MD 1.6)
- Bucket, General Purpose 600mm / 0.32m<sup>3</sup> with Kprime P015 x3 KGA (MD 1.6)
- Bucket, General Purpose 600mm / 0.32m<sup>3</sup> with XS15 x3 KGA (MD 1.6)
- Bucket, General Purpose 900mm / 0.53m<sup>3</sup> with Kprime P015 x4 KGA (MD 1.6)
- Bucket, General Purpose 900mm / 0.53m<sup>3</sup> with XS15 x4 KGA (MD 1.6)
- Bucket, Slope Finishing 1600mm / 0.75m<sup>3</sup> with Bolt on Edge KGA (MD 1.0)
- Bucket, Slope Finishing 1600mm / 0.96m<sup>3</sup> with Bolt on Edge KGA (MD 1.0)
- Bucket, Slope Finishing Tilting 1520mm / 0.709m<sup>3</sup> with Bolt on Edge KGA (MD 1.0)
- Quick Hitch Hydraulic Dual Lock Multi Pick-Up KGA
- Ripper, Single Tyne with Kprime P025 KGA
- Ripper, Single Tyne with XS25 KGA

---

## For more information:

**Australia - Ph:** 1300 199 054 | **Web:** [komatsu.com.au](http://komatsu.com.au)

**New Zealand - Ph:** 0800 433 116 | **Web:** [komatsu.co.nz](http://komatsu.co.nz)

# KOMATSU

