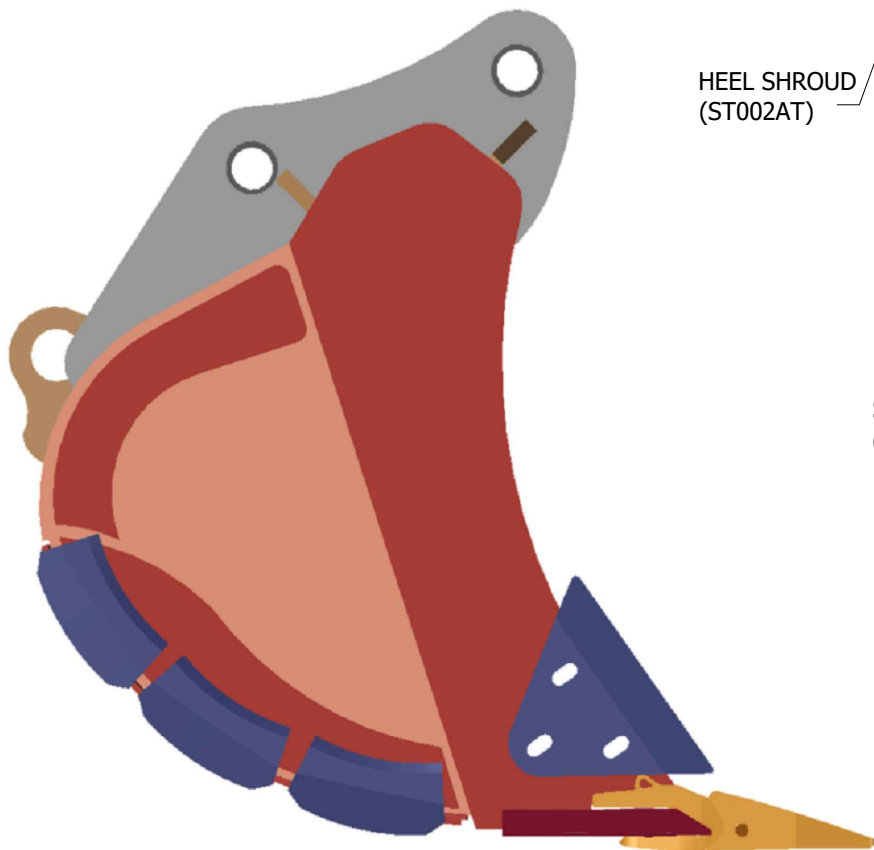
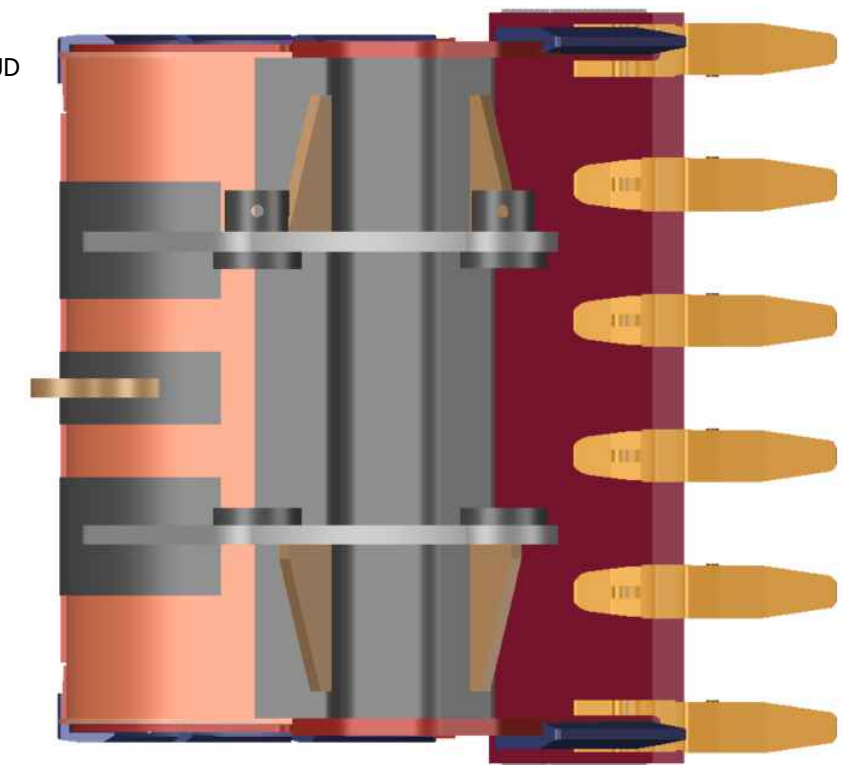
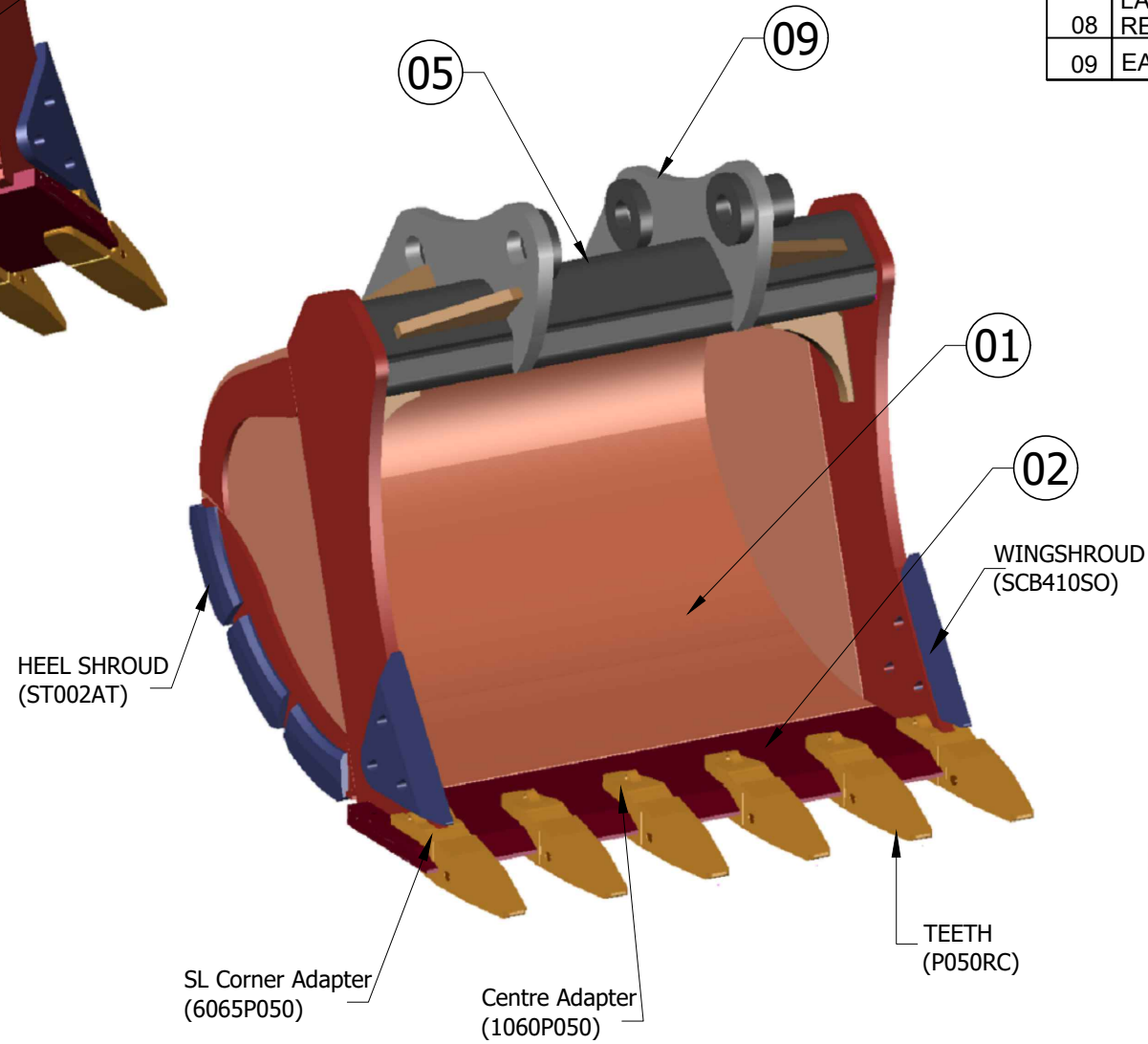
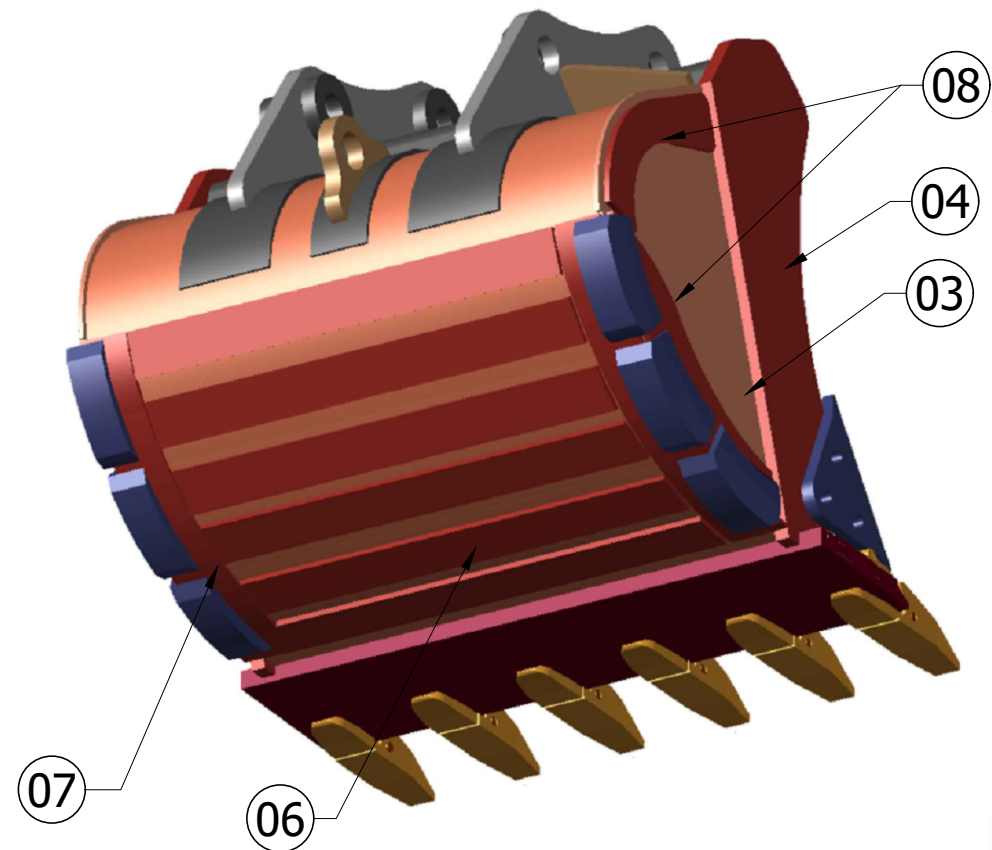

TABLE					
CODE	MODEL	WIDTH (mm)	CAPACITY(SAE1:1)	N° TEETH	TYPE of TEETH
E40XHDKME1770KPC450-8R	EXTRA HEAVY DUTY BUCKET	1770	2.1 Cu.m	6	KOMATSU 1060P050

NO.	DESCRIPTION	MATERIALS	THICKNESS (mm)	QTY
01	BOTTOM	S355JO	12	1
02	BLADE	HARDOX450 / EQ	60	1
03	BODY SIDE	S355JO	12	2
04	BODY SIDE REINFORCEMENT	HARDOX450 / EQ	40	2
05	CROSSBAR	S355JO	20	1
06	BOTTOM HORIZONTAL REINFORCEMENT	HARDOX450 / EQ	20	6
07	BOTTOM VERTICAL REINFORCEMENT	HARDOX450 / EQ	20	2
08	LATERAL SIDE REINFORCEMENT	HARDOX450 / EQ	15	4
09	EAR PLATE PC450-8R	S355JO	40	2



AGT	CHECKED BY
SKP	DRAWN BY
15.05.2024	MOD. DATE
ISSUED FOR APPROVAL	DESCRIPTION
0	REV.

CODE : E40XHDKME1770KPC450-8R

TITLE : EXTRA HEAVY DUTY BUCKET WIDTH 1770MM X CAP. 2.10 Cu. m. Cap. FOR KOMATSU PC450-8R EXCAVATOR MACHINE

© 2018-2023 - NBE  
All Rights Reserved.



NEW BUCKETS ENGINEERING FZCO  
Jebel Ali Free Zone, Dubai, UAE  
Tel. +971 4 8810445  
www.newbucketsengineering.com

1:50, 1:100  
SCALE AT A4

