

# **TIMBERPRO**

A Komatsu forestry brand

**TL745D**  
feller buncher



Photo may include optional equipment

**Operating weight**  
71,911 lbs. (32,618 kg)

**Rated horsepower**  
350 HP (261 kW) @ 1,800 rpm

## Specifications

### Engine

Model	Cummins L9	
Type	Water cooled, 4-cycle, XPI fuel system	
Aspiration	eVGT, after cooled	
No. of cylinders	6	
Bore	4.49 in	114 mm
Stroke	5.86 in	145 mm
Engine displacement	543 in <sup>3</sup>	8.9 L
Horsepower		
SAE J1995	Rated 350 HP (261 kW) @ 1,800 rpm	
Fan drive type for radiator cooling	Hydraulic, variable speed, auto reverse	
Governor	All-speed control, electronic	
Peak engine torque	1,151 lb-ft (1,561 Nm)	

U.S. EPA Tier 4 Final emission certification

### Hydraulic system

Type: load sense, pressure compensated, open loop system and dedicated closed loop systems

Hydraulic control modes	SAE/US/US mod, custom attachment settings	
Pumps	Implement, swing, attachment, dual track, charge, fan, auxiliary	
Main pump type	Variable displacement piston type	
Saw flow	39 gpm	108 L/min
Implement flow	115 gpm	435 L/min

### Coolant (refilling) and lubricant capacity

Fuel tank	220 gal	833 L
Coolant	13.5 gal	51 L
Engine	6.25 gal	23.6 L
Hydraulic tank	64 gal	242 L
DEF tank	15 gal	56.8 L

### Operating weight

Operating weight	71,911 lbs.	32,618 kg
------------------	-------------	-----------

### Swing system

Drive method	Hydrostatic	
Swing reduction	Planetary gear	
Swing circle, lubrication	Internal tooth, greased	
Holding brake/swing lock	Oil bath multi-disk, spring applied, hydraulic release	
Swing speed	6.7 rpm	
Swing torque	57,800 lbs.-ft (78.4 kN/m)	
Maximum reach to pin	23' 10" (7,275 mm)	
Max cutting swath	15' 10" (4,837 mm)	
Max tail swing radius	5' 10" (1,778 mm)	
Lift capacity @ 20' (6.1 m), @ 4' 11" (1.5 m) above ground	14,500 lbs. (6,590 kg)	
Cutting radius - minimum, @ 4' 11" (1.5 m) above ground	8' (2,438 mm)	
Bare pin lift at full reach, @ 4' 11" (1.5 m) above ground	10,000 lbs. (4,545 kg)	

### Frame, drive and axles

Center frame type/design	HD boxed frame structure with flat bottom, storage trunk, integrated fuel tank	
Track frame type/design	HD boxed structure, with shoe support	
Drive/travel motor type	Hydrostatic	
Final drive	Planetary gear	
Track link type	Greased, sealed	
Track adjuster type	Grease adj, spring tension	
Link pitch	8.5" (216 mm)	
Number of links (per side)	48	
Number of lower track rollers (per side)	10	
Track carrier type, how many (each side)	Slider, dual	
Travel speed	Two speed ranges	
Parking brake method	Oil bath multi-disk holding brake, spring applied, hydraulic release	
Steering controls	Pedals	
Shoe width (std)	600 mm	
Shoe width (max)	700 mm	
Maximum drawbar pull	71,476 lbf (32,489 kgf)	
Cab leveling front/rear/side, degrees	24/7/24	

# Dimensions

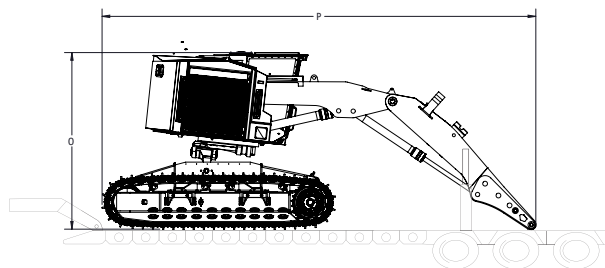
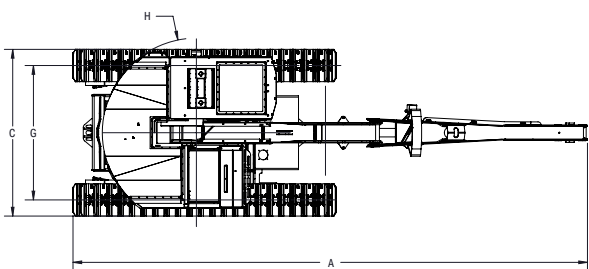
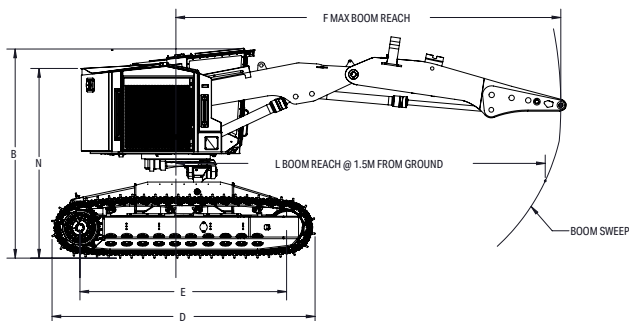

Transport dimensions: See C, O and P

## Dimensions and weights

A	Overall length full reach	31' 10" (9,728 mm)
B	Overall height highest point body	13' 0" (3,692 mm)
C*	Overall transport width	10' 4" (3,150 mm)
D	Track length - overall	16' 5" (5,000 mm)
E	Track length on ground	12' 10" (3,910 mm)
F	Max boom reach	23' 10" (7,275 mm)
G	Track gauge	8' 4" (2,539 mm)
H	Max tail swing radius	5' 10" (1,778 mm)
I	Ground clearance, center frame (std GR)	2' 8" (806 mm)
J	Overall body width, widest point	9' 8" (2,950 mm)
K	Ground clearance, revo frame (std GR)	6' 6" (1,981 mm)
L	Boom reach @ 4' 11" (1.5 m) above ground	22' 11" (6,985 mm)
N	Machine height, rear of engine hood	11' 9" (3,581 mm)
O	Overall height for transport (std)	12' 3" (3,734 mm)
P	Length on ground for transport	30' 4" (9,246 mm)
	Ground pressure	9.2 psi (0.64 kg/cm <sup>2</sup> )

\*With 600 mm tracks

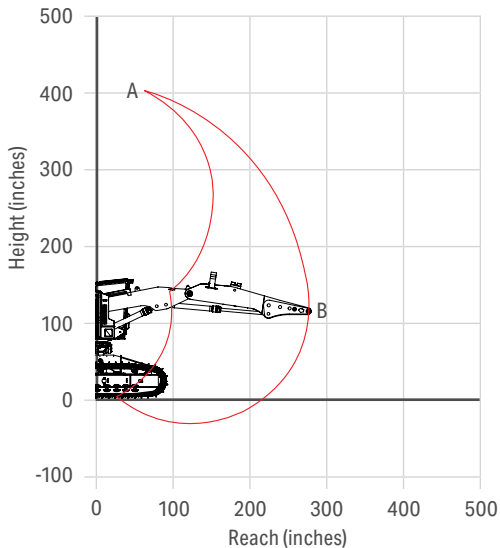
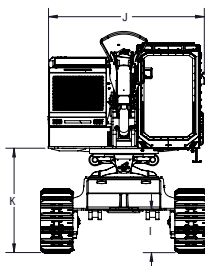

## Range of motion chart TL745D feller buncher

A	33' 5" (10,180 mm)
B	23' 10" (7,275 mm) @ 4' 11" (1.5 m) above ground

# Equipment

## Engine and related components

350 HP (261 kW) Cummins QSL9 (Stage V)	●
1,151 lb-ft (1,561 Nm) @ 1,800 rpm	●
Single module DOC/DPF/SCR	●
eVGT, after cooled	●
Hydraulic variable speed cooling fan with auto reverse	●
Air cleaner, dual element with dust collector	●

## Operator environment

ROPS/FOPS/OPS certified cabin with three egress routes	●
Reinforced roof hatch, removal tool	●
Skylight	●
1.25" (32 mm) front window	●
Digital climate control system, filtered fresh air intake and pressurized cabin	●
AM/FM/WB radio with Bluetooth® handsfree and USB input	●
IQAN MD4 HD control system with 10" touchscreen	●
Left and right joystick electrohydraulic proportional controls for machine operation	●
Coordinated boom operations	●
4-way leveling	●
Automatic leveling control	○
Variable speed travel control	●
Standard seat – air ride and heated, high back with lumbar adjust, folding armrests	●
Deluxe seat – air ride, heated and cooled, high back with lumbar adjust, folding armrests	○
4 pt seat belt harness	●
Rear mounted camera system with dedicated monitor	●
Travel alarm	●
Auxiliary power port connector, 12V	●
Interior LED lights	●
Fire extinguisher	●
English decals	●
Paint - TimberPro red	●
Paint - custom color	○

## Serviceability

Rearward open engine hood, power raise	●
Perforated panel, heavy duty service doors and side-hinged cooler doors with tool-less latch closures	●
Retractable step for operators cabin	●
Hydraulic tank electric vacuum system	●
Electric hydraulic oil fill transfer pump	●
Storage trunk, ground level access	●

## Electrical system

24V electrical system with battery disconnect	●
Alternator, 100 ampere, 24V	●
Batteries, 2×12V	●
Battery disconnect switch	●
Working lights - LED high intensity lighting	●
LED lighting on work equipment, guarded	●

Standard equipment	●
Optional equipment	○

TimberPro Inc reserves the right to change specifications without notice or obligation. Product illustrations may be equipped with optional equipment.

Product designs, specifications and/or data in this document are provided for informational purposes only and are not warranties of any kind. Product designs and/or specifications may be changed at any time without notice. The only warranties that apply to sales of products and services are Komatsu's standard written warranties, which will be furnished upon request.

Komatsu and other trademarks and service marks used herein are the property of Komatsu Ltd., Komatsu America Corp., Komatsu Mining Corp. Komatsu Germany, or one of their affiliates, or the respective owners or licensees.

## Hydraulic system

Implement pump	●
Combination hydraulics, valves and plumbing for harvester configuration	○
Charge filter non-bypass, 6 micron	●
Return filters with bypass, 10 micron	●
Case drain filter with bypass, 10 micron	●
Hydraulic air-to-oil cooler	●
Feller buncher standard hydraulics, hot saw only	●
Feller buncher combination hydraulics	○
Harvester hydraulics, telescopic arm	○
Hydraulics for other attachments	○

## Guards and covers

Work equipment cylinder guards, deflector	○
Sliding protective cover, boom to chimney	○
Carbody debris shields, rubber	●
Boom lines debris shields, rubber	○
Track rail rock guards, full length	●
Engine air intake deflector	●

## Frame, undercarriage and tracks

TL carbody, leveling	●
Standard width boxed frame flat bottom forestry carbody with storage trunk and fuel tank	●
Wide width boxed frame flat bottom forestry carbody with storage trunk and fuel tank	○
Wide width carbody with integrated tethering points	○
Heavy duty towing attachment point	●
24" (600 mm) single grouser track shoes	●
28" (700 mm) single grouser track shoes	○
Track carrier sliders, dual	●
Track rollers, heavy duty, 10 per side	●
48 links per side, sealed	●
Heavy duty spring track tensioner	●
Parking/travel brake, wet multi-disk, hydraulic release	●

## Upper swing system, work equipment and attachments

Continuous rotation upper, dual-ball, lubricated swing mechanism	●
Planetary gear swing reduction drives, with wet multi-disk swing holding brake	●
Hydraulic swing energy recovery system	●
Feller buncher boom and arm work equipment, tool tilt	●
Feller buncher HD boom and arm, west coast, tool tilt	○
Processor (forwarder boom) and arm, telescopic arm	○

## Optional equipment

Komtrax monitoring system	○
Fire suppression system	○
Diesel Espar pre-heater with timer	○
120V AC plug-in engine block pre-heaters and plug-in hydraulic tank heater	○
Uptime kit	○

**KOMATSU**

komatsu.com

