

KOMATSU®

830E-5

ELECTRIC DRIVE TRUCK

830E-5



Photos may include optional equipment.

GROSS HORSEPOWER
2,500 HP 1865 kW

NOMINAL GVW
906,400 lb 401136 kg

WALK-AROUND

PRODUCTIVITY FEATURES

- High performance Komatsu SDA16V160 engine Gross Horsepower 1865 kW **2,500 HP**
- 3207 kW **4,300 HP** retarding
- Traction (spin-slide) control
- Cruise control
- Komatsu designed application specific body
- Tight turning radius 14 m **45' 9"**
- Payload Meter IV®

ENVIRONMENTALLY FRIENDLY

- Komatsu SDA16V160 engine with after-treatment meets U.S. EPA Tier 4 Final emissions regulations
- Fuel efficient engine
- Less fluids compared to mechanical drive trucks



Photos may include optional equipment.

HORSEPOWER

Gross: 2,500 HP 1865 kW

NOMINAL PAYLOAD

250 US tons 227 metric tons



OPERATOR ENVIRONMENT

- Ergonomically designed spacious cab with excellent visibility
- Fully adjustable driving position settings
- Four post ROPS/FOPS level 2 cab
- User friendly display with payload information
- Komatsu Hydrair® II suspensions designed for optimum ride comfort
- AM/FM/MP3/USB/weather band radio



EASY MAINTENANCE

- KOMTRAX Plus allows immediate diagnostics of key engine, chassis, and drive system components
- Automatic lubrication system
- Eliminator® oil filtration system
- Flange mounted rims with optional Komatsu Smart, speed type rims
- In-tank and remote fast fuel
- Oil-cooled, wet disc, front braking system reduces wear and extends replacement intervals

RELIABILITY FEATURES

- Frame design optimized for 227 metric tons **250 US tons**
- Simple and reliable hydraulic system
- Steering and brake accumulators

PRODUCTIVITY FEATURES

Komatsu High Horsepower Engine

Komatsu's 2500 HP engine will operate in most of today's mining applications without experiencing power derate. Fuel efficiency is maximized due to optimized air handling.

Standard features include:

- A standard pre-lube system designed to reduce start-up wear and increase overhaul life.
- CENSE® on board monitoring of engine performance for each cylinder.
- ELIMINATOR® filtration system reduces oil and filter changes by one-third.

IGBT AC Electric Drive System

The GTA51 traction alternator coupled with GEB36 wheelmotors and Invertex IIe® AC control system provides reliable performance and easy maintenance. Invertex IIe® offers independent control of the rear wheelmotors, which in turn provides outstanding traction-ability during wet and slippery conditions, thus improving tire wear and operator confidence.

The air cooled Insulated Gate Bipolar Transistor (IGBT) inverter system technology provides the highest available reliability. The IGBT inverter is more compact and much simpler than the design of its predecessor, the Gate Turn Off (GTO) inverter, which improves serviceability and routine maintenance.

Electric Dynamic Retarder

The 3207 kW **4,300 HP** retarding system provides state of the art braking capacity for navigating today's mining applications which contain steep continuous descents and sharp switch-backs. Continuous retarding capacity enhances the productivity of the vehicle operator, while eliminating the need for excessive mechanical braking effort.



Traction (Spin-Slide) Control

During slippery conditions, the 830E-5 wheel traction control technology detects and corrects wheel spin or slide events. Traction control operates automatically and independently of the service brakes. During propulsion, “wheel slip control” reduces non-productive wheel spin in low traction conditions. During retarding, “wheel slide control” prevents wheel lockup and potential subsequent sliding.

Cruise Control

Cruise control, both in propulsion and retarding, allows the operator to concentrate on steering and situational awareness while maintaining a constant speed. A set speed indicator provides confirmation the truck speed matches the desired speed selected by the operator, with simple automotive style controls.

Komatsu Designed Application Specific Body

Utilizing the required Body Worksheet (BW) process, Komatsu ensures that each body is designed to meet the requirements for each specific application while carrying its rated payload. Komatsu works with each customer to understand all of the material properties at a mine site and to identify the appropriate liner package.

Komatsu offers a standard all-welded steel, flat floor body with a full canopy and horizontal bolsters. This body includes a driver side eyebrow, body up sling, and rubber mounts on the frame.

- Standard Body SAE Heaped 2:1: 158 m³ **207 yd³**
- Standard Komatsu Body Weight: 29830 kg **65,762 lbs**



PRODUCTIVITY FEATURES



830E-5

Tight Turning Radius

By using double acting hydraulic steering cylinders with a six-point articulation linkage, the 830E-5 power steering system provides positive steering control with minimal operator effort. The turning radius of the 830E-5 is 14 m **46'**, which provides excellent maneuverability for tight loading and dumping conditions. The steering accumulators comply with ISO-5010 standards.

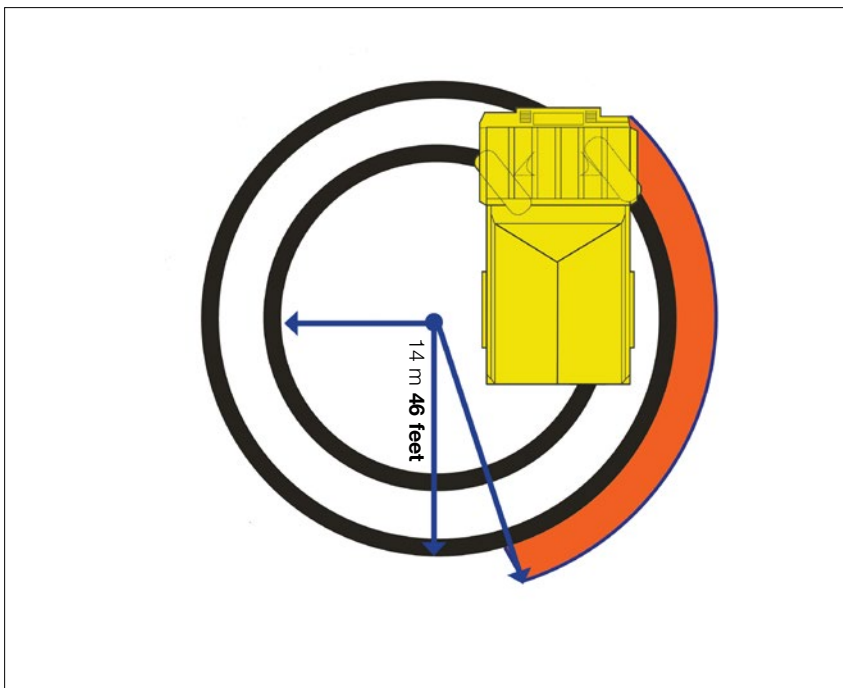

Payload Meter IV (PLM IV®)

PLM IV® is an electronic system that monitors and records payload information for Komatsu's off-highway mining trucks. The accurate and reliable payload measurement system is designed to help optimize payload, maximize productivity and reduce the life cycle cost of the machine. PLM IV® tracks and records the following key production parameters:

- Payload
- Empty Carry-Back
- Operator Identification
- Haul Cycle, Loading, Dumping Time and Date
- Distance Traveled (Loaded and Empty)
- Cycle Time Information
- Maximum Speeds (Loaded and Empty)
- TMPH Estimate for Front and Rear Tires
- Average Speed (Loaded and Empty)

Hydrair II® Hydropneumatic Suspension

Hydrair II® is a suspension system that utilizes four nitrogen-over-oil cylinders. This suspension system is designed to maximize machine productivity by providing the operator with a smooth and comfortable ride. By absorbing shocks to the chassis during operation, Hydrair II® contributes to the durability of the machine's frame and components.



OPERATOR ENVIRONMENT

Operator Seat

Komatsu recognizes that operator comfort is a key to productivity in today's mining environment. The five-way adjustable operator seat and the tilt-telescopic steering column provides an optimum driving posture for increased operator comfort and control over the machine. The air suspension seat absorbs vibrations transmitted from the machine, reducing operator fatigue. A 51 mm **2 in** wide, blaze orange, three-point seat belt is provided as standard equipment.

Built-in ROPS and FOPS Structure

These structures conform to ISO standards 3471 and 3449.

Ergonomically Designed Cab

The Komatsu 830E-5 cab design provides a comfortable and productive environment to meet today's mining demands. The cab includes tinted safety glass windows, heating and air conditioning, acoustical insulation, double sealed doors and filtered and pressurized air to reduce dust.

User Friendly Display

The 830E-5 comes with a new operator friendly dash configuration which includes lighted gauges, switches and information panel. This allows the operator to see the status of the machine during operation and informs them of any faults. An instructive message will appear after any fault is detected on the machine.



Photo may include optional equipment.

TIER 4 AND ELECTRIFICATION

830E-5

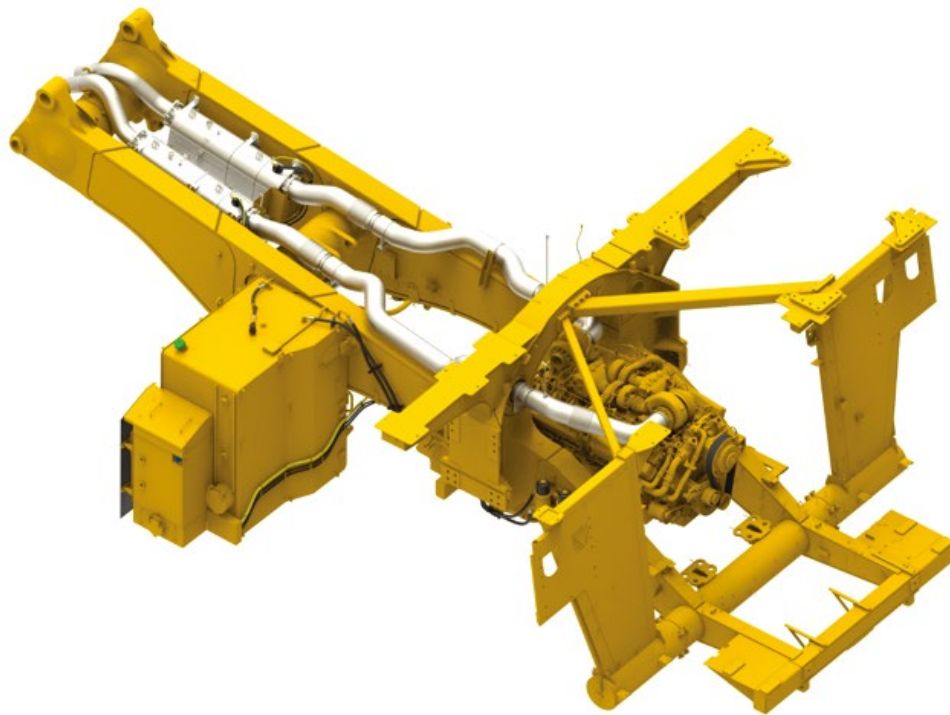

Evolutionary, not Revolutionary Design

Komatsu's Tier 4 solution begins with a base engine which is very similar to the previous Tier 2 platform. In keeping the basic operation of the engine the same, durability is assured. Utilizing High Pressure Common Rail fuel delivery ensures atomization of the fuel/air mixture to a level which reduces particulate matter, meeting U.S. EPA Tier 4 standards.

Komatsu After-treatment

Removal of NOx is accomplished by treating the exhaust through Selective Catalytic Reduction (SCR). The introduction of Diesel Exhaust Fluid (DEF) into the SCR canister generates a chemical reaction which breaks down the oxides of nitrogen into oxygen and nitrogen, both non-pollutants. Internal cleaning of the SCR is performed through an automatic process.



On-Demand Cooling

- Separate cooling circuits for control group and wheel motor systems
- Allows intelligent control of cooling
- Maintain optimal temperatures for each system

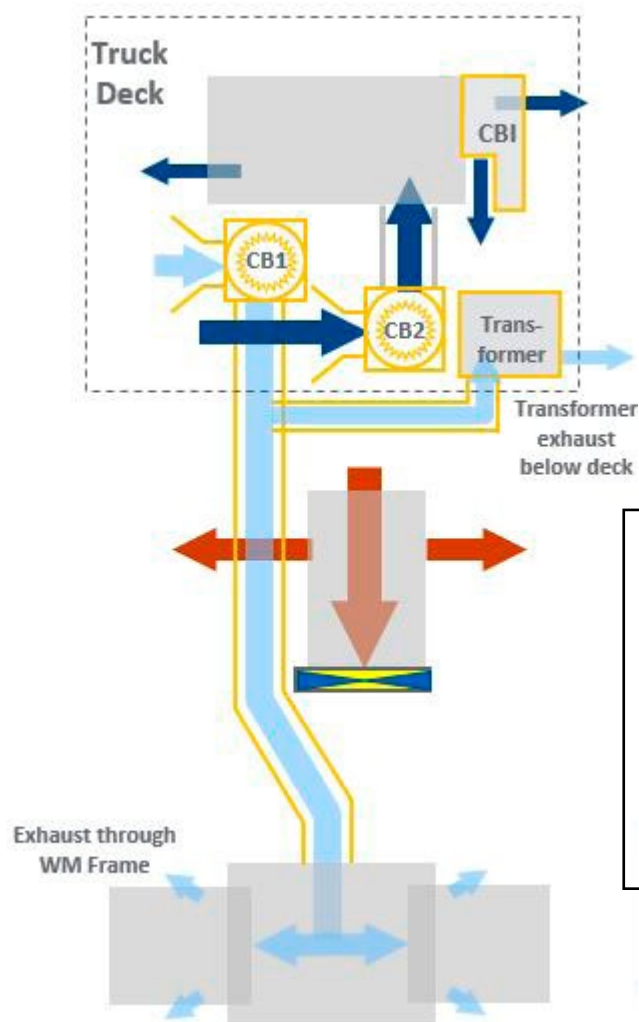

Alternator Self-Cooling Only

- Reduced impeller size by 25%
- Reduced cooling housing/impeller
- 500 lb 227 kg weight reduction

Uses Wheel Motor generator retarding energy for cooling

- Control Group
- Wheel Motors
- Grid Blower

RELIABILITY FEATURES

Structurally Enhanced Frame Design

By using advanced computer-aided design, finite element analysis, and full-scale dynamic testing, the frame has been designed to carry 227 metric tons 250 short tons and provides the high structural reliability Komatsu is known for.

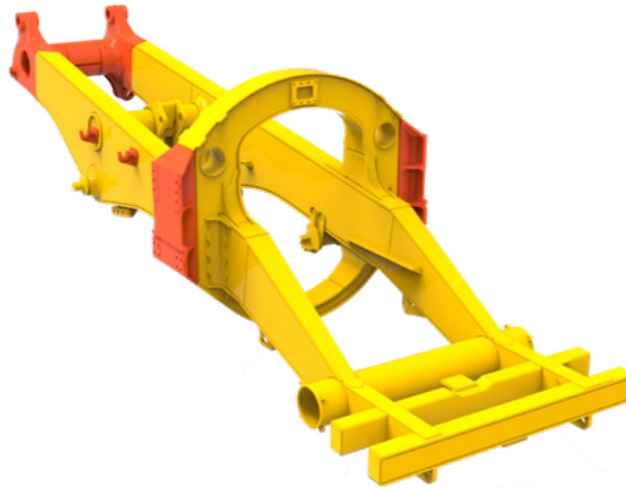

Castings Used in High Stress Areas

To increase frame reliability, steel castings have been incorporated at key frame pivot points and critical load bearing portions of the structure. This includes the rear body pivot and horsecollar sections.

Simple and Reliable Hydraulic System

The hydraulic system is a proven and reliable design with fewer parts than other OEMs. The system utilizes a single tank, providing one common source of fluid for steering, braking, and hoisting. In-line, replaceable filtration elements provide protection from hydraulic system contamination, making the system easier to service.

To keep downtime to a minimum, Komatsu developed a sub-frame pump module that can be removed and replaced as a single unit. This reduces change-out time and allows easy access to the hydraulic pump module.



Proven Wheel Motor Design

The GEB36 wheel motor builds on the success of its predecessor. Held to the highest standards, the transmission was subjected to extensive testing and quality confirmation. A full scale controlled durability and field test was conducted at Komatsu's Proving Grounds during development to confirm design quality prior to production. By using planetary design, extensive machining is not required during a standard rebuild.

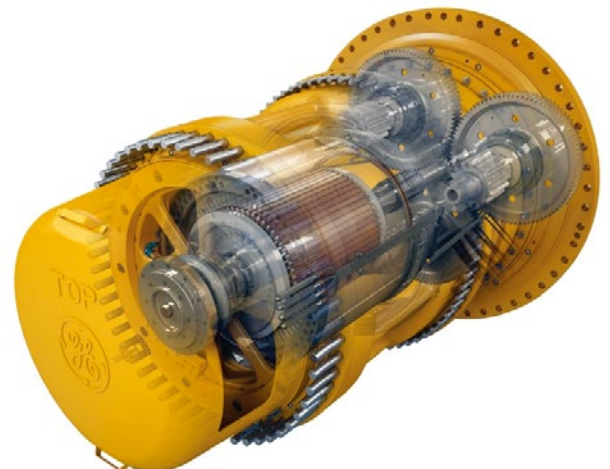

Fully Hydraulic Controlled Multiple-Disc Front Wet Brakes

While the dynamic retarding system is the primary braking force, the 830E-5 comes standard with front-wheel, hydraulically actuated, oil-cooled service brakes and rear-wheel, dual disc, dry brakes. In the event that the truck's hydraulic system pressure drops below an acceptable level, the accumulators will automatically apply front and rear brakes to bring the truck to a complete stop.

Max. service apply pressure: 13,100 kPa 1,900 psi

Total friction area per brake: 61,016 cm² 9,458 in²

The oil-cooled brake system provides lower maintenance costs and higher reliability versus dry disc brakes. This system is fully sealed to help keep contaminants out and reduce brake wear and maintenance. The brakes are hydraulically actuated; no pneumatic system is used. There are three independent hydraulic circuits that provide hydraulic back-up.

Rear-Wheel Hydraulically Actuated Dry Disc Brakes

- Rear Dual 25 in (635 mm) Diameter Disc with a single Caliper per disc
- Static Dry Disc Park Brakes
- Park Brake will not apply at truck speeds above 0.8 km/h or 0.5 mph
- Rated to Hold Maximum GVW @15% Grade

System meets ISO 3450-2011



EASY MAINTENANCE

Access, Service and Convenience

Located on the front left bumper adjacent to the main entry to the machine, Komatsu installs many service and convenience items. This central location simplifies maintenance events, reducing the time the truck is out of service for routine upkeep.

1. Auto-lubrication tank and controls (right side)
2. Power, starter and drive system lockout (lock-out/tag-out capable switches)
3. Emergency engine shut-down
4. Fluid service center (coolant, engine oil, hydraulic oil, grease fill)
5. Hydraulic step up/down switch (hydraulic stairs are optional)

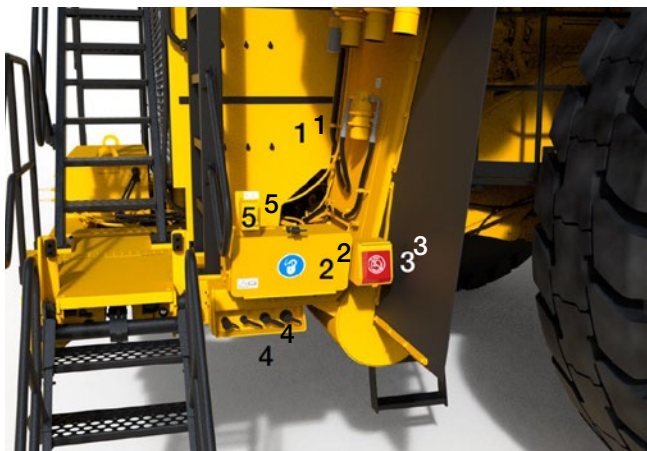

KOMTRAX Plus

As part of a complete service and support program, Komatsu equips every mining and quarry sized machine with KOMTRAX Plus. By using a satellite-based communication system, KOMTRAX Plus offers a new vision of monitoring your valuable assets. By providing insight to critical operating metrics the user can manage increased availability, lower owning and operating costs and maximize fuel efficiency.

The information available through KOMTRAX Plus allows service personnel to review faults and trends, improve the quality of the troubleshooting process and reduce unscheduled machine downtime.

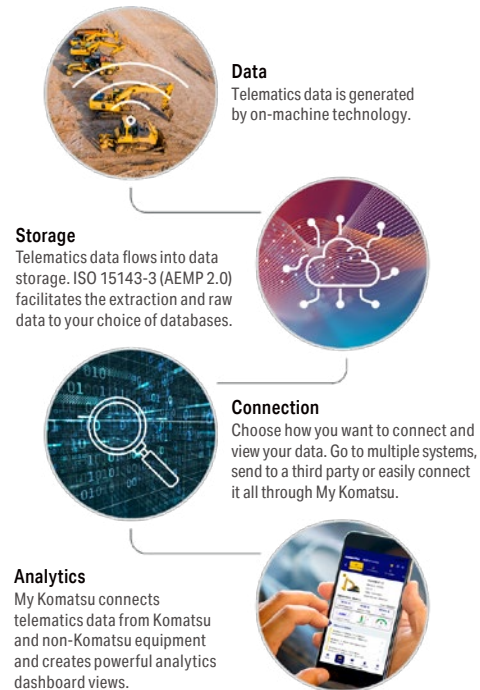

Flange Type Tire Rims

Komatsu Smart rim technology allows easy removal and installation of the tires to minimize the overall impact on downtime.

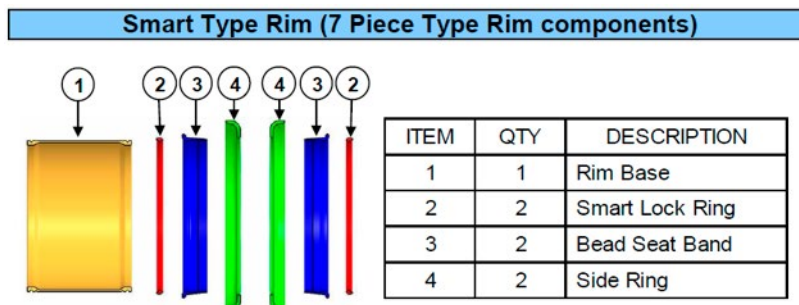

DRIVE SYSTEM

Drive System (Invertex IIe)

- Cooling Blower Inverters (CBI)
- True Quad Chopper Eliminates RP Contactors
- Only Single Stack IGBT's
- From 24 to 12 Traction IGBT's Reduces Weight & Size
- Meets IP54 for Dust & Moisture Control
- Increased Cabinet Rigidity
- Reduced Rigid Multi-axis Joints
- Fiber Optic Cards Integrated Into Backplane
- Front Placement of Indicator & Interface Panels
- Front Access for Maintenance
- All LED Lighting

Improved Bus Bar

- Close Molded Design- Eliminates Potting
- No Soldered Bushings
- Edge Protection
- FR4 & Abrasion Protection
- Simplified, More Robust Bus Bar Design

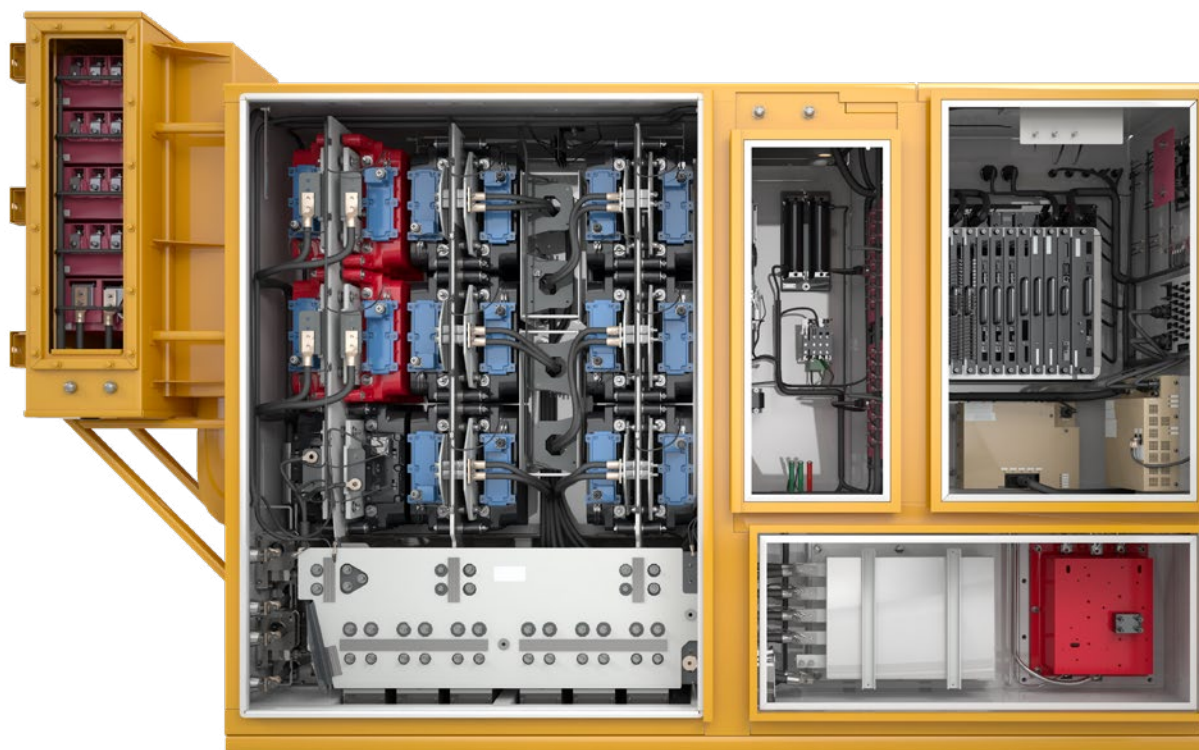

ADDITIONAL FEATURES

Environmentally Friendly

Less Fluids than Mechanical Drives

Komatsu electric drive trucks contain 57% less hydraulic fluid compared to similar class mechanical drive trucks, creating a lower environmental impact and makes fluid replacement simpler, quicker and more economical.

U.S. EPA Compliant

The Komatsu SDA16V160 engine is compliant with the U.S. EPA Tier 4 emissions regulations.

Reduced Fuel Consumption

The engine and drive system are specifically tuned together, providing efficient power usage and minimizing fuel consumption.

Komatsu Loading Policy for Mining Trucks

In normal loading operations, variations in payloads occur. The loading policy identifies the guidelines and limitations for the loading of those Komatsu Mining Truck models specified.

Definitions:

- **Rated GVW** (Gross Vehicle Weight) includes the chassis, body, tires, accessories (including local options), lube, fuel, operator, payload and any excess material build-up.
- **Rated Payload** is the resultant difference of Rated GVW minus EVW.
- **Overload** refers to any payload amount in excess of the Rated Payload.
- **Never to exceed GVW** is the maximum allow able GVW under the guidelines of this Policy.

Actual payloads greater than the Rated Payload are allowable, but shall not result in a GVW that is greater than the Never to Exceed GVW.

No single payload that results in a **GVW** in excess of the Never to Exceed GVW is allowed under any circumstances.

The mean of all payloads for a rolling 30-day period shall not exceed the Rated Payload.

Truck Model	830E-5	
Specification	lb	kg
Rated GVW	906,400	411,136
Standard Tire Size	50/80R57	
Rated / Nominal Payload	500,000	226,800
Never To Exceed GVW	1,006,367	456,480

SPECIFICATIONS



ENGINE

Make and model.....Komatsu SDA16V160
 Fuel Diesel
 Number of cylinders 16
 Operating cycle 4 cycle
 Gross horsepower*..... 1865 kW **2,500 HP** @ 1800 rpm
 Net flywheel power**..... 1778 kW **2,385 HP** @ 1800 rpm
 Weight (wet)8558 kg **18,867 lb**
 Weight (dry)8099 kg **17,857 lb**

* Optional Tier 4 emissions compliant engine for North American market. Non-emissionized engine for markets outside of North America

* Gross horsepower is the output of the engine as installed in this machine, at governed rpm and with engine manufacturer's approved fuel setting. Accessory losses included are water pump, fuel pump and oil pump.

**Net flywheel power is the rated power at the engine flywheel minus the average accessory losses. Accessories include fan and charging alternator. Rating(s) represent net engine performance in accordance with SAE J1349 conditions.



ELECTRIC DRIVE

AC/DC CURRENT

Alternator..... GTA-51
 Dual impeller in-line blower71.2 m³/min 2,515 cfm
 Control AC Torque Control System
 Motorized wheels* GEB36 Induction Traction Motors
 Ratio.....32.22:1
 Speed (maximum) 64.5 km/h **40 mph**

* Drive system performance depends upon gross vehicle weight, haul road grade, haul road length, rolling resistance and other parameters. Komatsu must analyze each job condition to assure proper application.



TIRES AND RIMS

Rock service, tubeless, radial tires
 Standard tire*.....50/80 R57
 Flange mount, five piece rim
 813 mm x 1448 mm x 152 mm **32" x 57" x 6"** rim assembly.
 Rims rated at 827 kPa **120 psi** cold inflation pressure.

Typical tire weight..... 23016 kg **50,750 lb**

* Tires should meet application requirements for tkph/tmph, tread, compound, inflation pressure, ply rating or equivalent, etc.

* Tires sold separately.



CAB

Advanced Operator Environment with integral 4-post ROPS/FOPS Level 2 structure (ISO 3449), adjustable air suspension seat w/ lumbar support and arm rests, full-size passenger seat, maximum R-value insulation, tilt and telescoping steering column, electric windshield wipers w/washer, tinted safety glass, power windows, Payload Meter IV®, 55,000 Btu/hr heater and defroster, 21,600 Btu/hr air conditioning (HFC - 134A refrigerant).



SUSPENSION

Variable rate hydro-pneumatic with integral rebound control
 Max. front stroke 335 mm **13.2"**
 Max. rear stroke 279 mm **11.3"**
 Max. rear axle oscillation ±10.3°



FRAME

Advanced technology, full butt-welded box sectional ladder-type frame with integral ROPS supports, integral front bumper, rear tubular cross members, steel castings at all critical stress transition zones, rugged continuous horsecollar.

Plate material..... 482.6 mPa 70,000 psi
 tensile strength steel
 Casting material..... 620.5 mPa 90,000 psi
 tensile strength steel

Rail width..... 305 mm **12"**
 Rail depth (minimum) 864 mm **34"**
 Top and bottom plate thickness 32 mm **1.25"**
 Side plate thickness..... 16 mm **0.62"**
 Drive axle mounting Pin and spherical bushing
 Drive axle alignment..... Swing link between frame and axle



BODY

All-welded steel flat floor body with horizontal bolsters and full canopy. Rubber mounts on frame, eyebrow and body up sling are standard. Extended canopy and pivot exhaust heating are optional.

Floor sheet 16 mm **0.63"** Outer 19 mm **0.75"** Center
 1379 MPa **200,000 psi** tensile strength steel
 Front sheet 12 mm **0.47"** Outer 12 mm **0.47"** Center
 1379 MPa **200,000 psi** tensile strength steel
 Side sheet 8 mm **0.39"** 1379 MPa
 1379 MPa **200,000 psi** tensile strength steel
 Canopy sheet 5 mm **0.19"** 690 MPa
 689 MPa **100,000 psi** tensile strength steel
 SAE heaped 2:1..... 158 m³ **207 yd³**
 Standard Komatsu body weight 29830 kg **65,762 lb**



BRAKING SYSTEM

Service brakes..... All hydraulically actuated
 Traction system Wheel spin-slide control
 Max. service apply pressure 13100 kPa **1,900 psi**
 Total friction area per brake 61016 cm² **9,458 in²**
 Auto apply system Automatically applied prior to hydraulic
 system pressure dropping below level required to meet
 secondary stopping requirements
 Secondary brake system Complies with ISO-3450 Standards
 Wheel brake lock Switch activated
 Parking brakes Multiple disc,
 spring-applied, hydraulically-released, dry brakes on inboard
 end of each wheel motor rotor shaft. Rated to hold on
 ±15% grade at maximum gross vehicle weight.
 Electric dynamic retarder..... 3207 kW **4,300 HP**



COOLING SYSTEM

L&M radiator assembly, split-flow, with deaerator-type top tank.
 Radiator frontal area 6.24 m² **67.2 ft²**

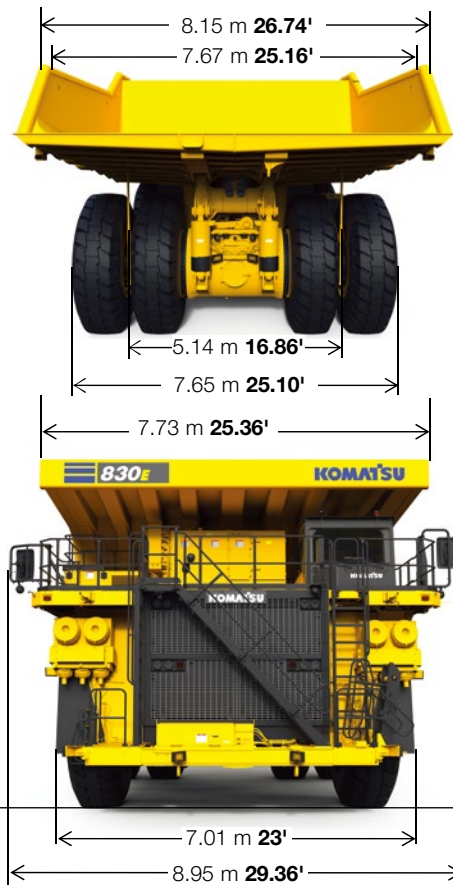
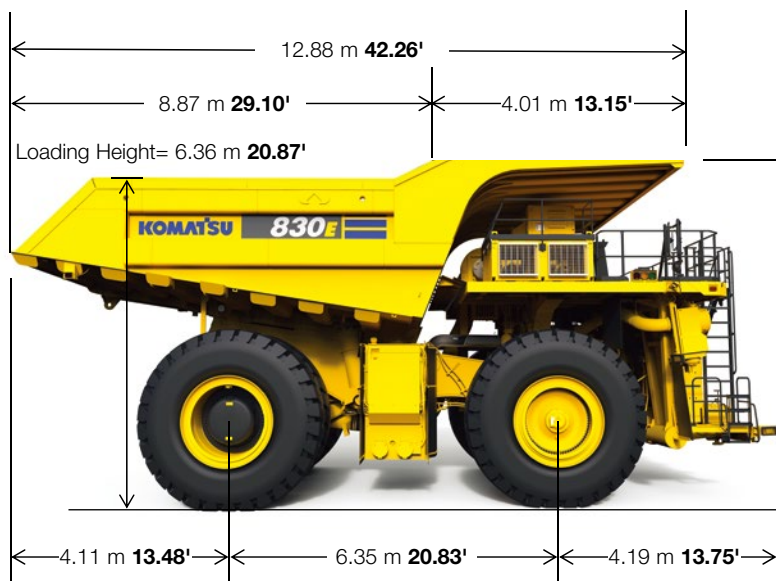

7.15 m
23.46'



HYDRAULIC SYSTEM

- Steering..... Accumulator assisted with twin double acting cylinders provide constant rate steering.
Secondary steering automatically supplied by accumulator.
- Turning circle diameter (SAE)..... 28 m **92'**
- Reservoir 947 L **250 U.S. gal**
- Filtration..... In-line replaceable elements
 - Suction Single, full-flow, 100 mesh
- Hoist and steering Dual, in-line, high pressure
- Brake component cabinet..... Above deck, easily accessible with diagnostic test connections
- Hoist Two 3-stage dual acting outboard cylinders, internal cushion valve, over-center dampening
- Hoist times
 - Power-up loaded 23 sec
 - Power-down 16 sec
 - Float-down empty 17 sec
- Pumps..... Two pumps, single package, in-line
- Hoist and brake cooling..... Tandem gear pump with output of 931 lpm **246 gpm** at 1900 rpm and 18960 kPa **2,750 psi**
- Steering and brake Pressure-compensating piston pump with output of 246 lpm **65 gpm** at 1900 rpm
- System relief pressures
 - Hoist 17237 kPa **2,500 psi**
 - Steering and brake 20685 kPa **3,000 psi**
- Ports available for powering disabled truck and for system diagnostics

Body	Capacity		Loading Height*
	Struck	2:1 Heap	
Standard	119 m ³ 156 yd³	158 m ³ 207 yd³	6.26 m 21'

*Exact load height may vary due to tire make, type, and inflation pressure.



ELECTRICAL SYSTEM

- 4 x 8D 1400 CCA, 12 volt, in series/parallel, 275 ampere-hour, bumper-mounted with disconnect switch & lock-out.
- Alternator 24 volt, 275 amp
- Lighting 24 volt
- Cranking motors Two/24 volt



SERVICE REFILL CAPACITIES

Cooling System	568 L	150 U.S. gal
Crankcase	363 L	96 U.S. gal
Hydraulic system	1325 L	350 U.S. gal
Motor gear box (each)	58 L	15 U.S. gal
Fuel tank	4542 L	1,200 U.S. gal
DEF tank	288 L	76 U.S. gal

SPECIFICATIONS

Truck Performance Graph

830E-5 PERFORMANCE

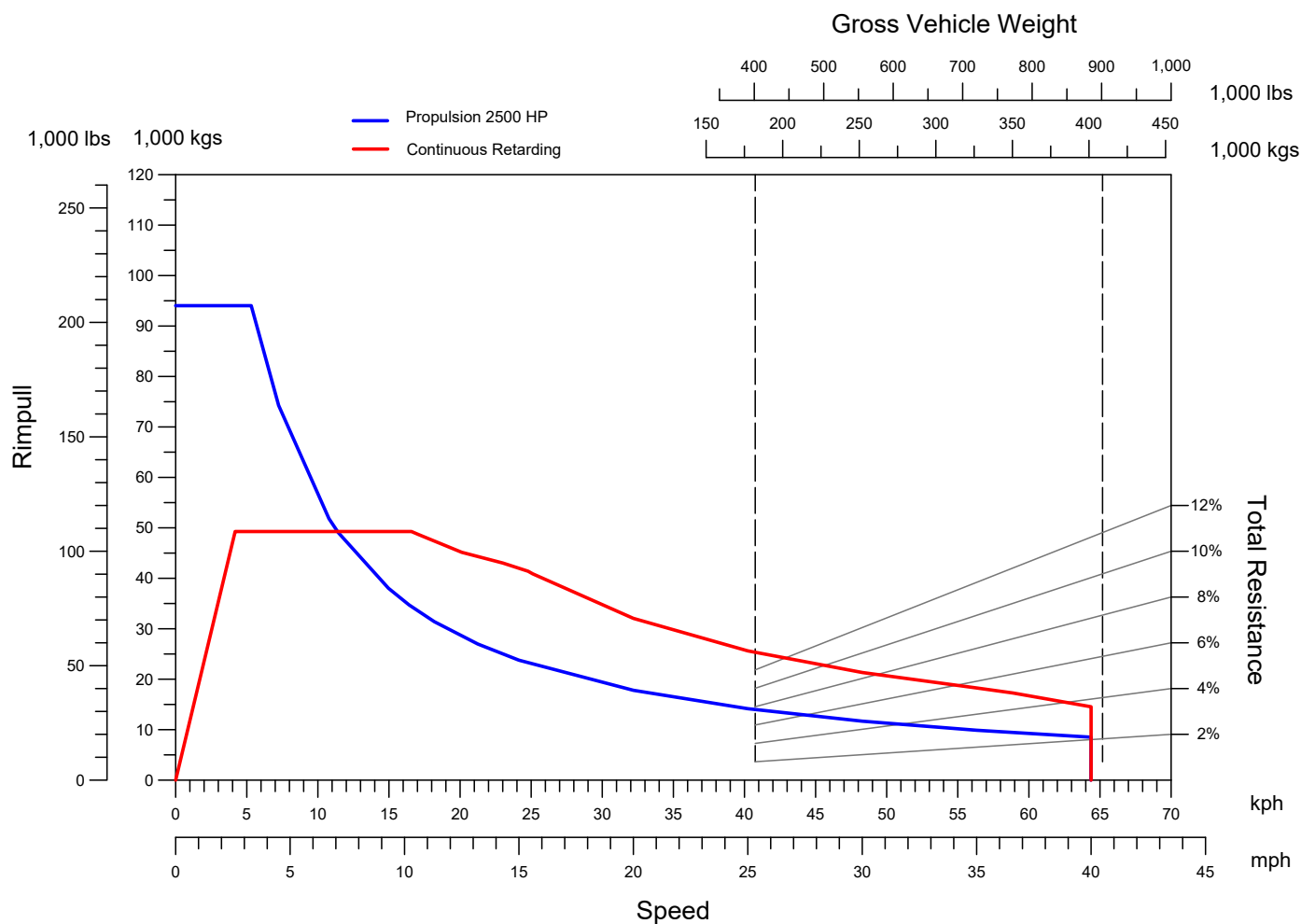

2500 HP - 50/80 R57 TIRES

Empty Vehicle Weight*

Front Axle Distribution	136684 kg	301,336 lbs	48%
Rear Axle Distribution	274452 kg	605,064 lbs	67%
Total EVW	411136 kg	906,400 lbs	

Gross Vehicle Weight

Front Axle Distribution	94457 kg	208,243 lbs	51%
Rear Axle Distribution	89863 kg	198,115 lbs	49%
Nominal GVW	184321 kg	406,358 lbs	

Payload

Nominal Payload	226800 kg	500,000 lbs
	227 metric tons	250 short tons

Nominal payload is defined by Komatsu America Corp's payload policy documentation. In general, the nominal payload must be adjusted for the specific vehicle configuration and site application. The figures above are provided for the basic product description purposes. Please contact your Komatsu distributor for specific application requirements.

*Includes options allowance





STANDARD EQUIPMENT

- Air cleaners, Donaldson® SSG w/ auto evacuators
- Alternator (Charging 24 volt/250A)
- Automatic lubrication system w/ground level fill, level indicator & dynamic timing
- Back-up alarm
- Batteries—4 x 8D (1450 CCA's)
- Battery charging/jump start connector
- Body over-center device
- Body-up sling (w/KAC supplied body)
- Cruise control
- Electric start
- Eliminator®, Cense®
- Fast-fill fuel system (in tank and left side remote)
- Filters, high pressure hydraulic
- Ground level radiator fill
- Hydraulically actuated rear dry disc brakes
- Mirrors, heated, multi-cambered convex LH & RH
- Mud flaps
- Muffled exhaust—deck-mounted
- Power supply, 24 volt to 12 volt DC
- Quick disconnects (steering, hoist and diagnostics)
- Radiator sight gauge
- Removable power module unit (radiator, engine, alternator)
- Reverse retarding
- Service center—LH
- Electronically controlled viscous fan clutch

OPERATOR ENVIRONMENT & CONTROL:

- All hydraulic service brakes with auto apply
- Battery disconnect switch
- Brake lock and drive system interlock
- Circuit breakers, 24 volt
- Diagonal staircase across grille
- Dynamic retarding with continuous rated element grids
- Engine shutdown at ground level
- Hoist propulsion interlock

- Horns (electric—front)
- Integral ROPS/FOPS Cab Level 2
- Maintenance and power lockout
- Parking brakes with warning light & speed application protection
- Power steering w/auto secondary steering
- Protective deck handrails
- Pump driveline protector
- Radiator fan guard
- Seat belts
 - Operator 3-point 51 mm 2" retractable
 - Passenger lap 51 mm 2" retractable
- Slip-resistant walkways

STANDARD HIGH VISIBILITY DELUXE CAB:

- AC drive interface display
- Air conditioner HFC-134A
- AM/FM radio, USB & MP3
- Dome light
- Electronic Dash & Status Panel
 - Body up
 - Engine oil temperature (high)
 - Parking brake
 - Propulsion system not ready
 - No DC link voltage
 - No propel
 - Service brake applied
 - Wheel brake lock applied
 - Maintenance monitor
- Engine hourmeter, oil pressure gauge, coolant temperature gauge, hydraulic oil temperature gauge
- Engine shutdown w/ "Smart Timer" delay
- Floor mat (double barrier)
- Fuel gauge in cab
- Fuel low level light and buzzer
- Gauges (w/backlight)
- Headlight switch
- Heater and defroster (heavy-duty)
- Heater switch
- High beam selector and indicator

- Horn switch (center of steering wheel)
- Indicator lights (blue)
 - Engine service
 - Komtrax Plus® snapshot (IM)
- Komatsu Payload Meter IV
- Komtrax Plus
- Operator seat, adjustable w/air suspension, lumbar support and arm rests
- Panel lighting (adjustable)
- Passenger seat, mechanical suspension
- Power windows
- Pressurized cab air system w/fan on
- Single brake/retarder pedal
- Sunvisor (adjustable)
- Tilt & telescoping steering column
- Voltmeter (battery output)
- Windshield (tinted safety glass)
- Windshield wiper (dual) and washer (electric)

LIGHTING:

- Back-up lights—rear mount (2) halogen
- Back-up lights—R and L—deck mount (2) halogen
- Brake and retard lights on top of cab
- Clearance lights (LED)
- Dynamic retarding, rear (2) (LED)
- Engine compartment service lights
- Fog lights (2) halogen
- Headlights (8) halogen
- Manual back-up light, switch and indicator
- Payload lights R and L (LED)
- Stairway lights
- Stop & tail lights (2) (LED)
- Turn signals (LED)



OPTIONAL EQUIPMENT

Note: Optional equipment may change operating weight.

- Amber Beacon Light
- Application Specific Body Structure
- Body liners
- Body up sling
- Bumper Mounted Headlights
- Double Wall Exhaust Tubes
- Engine Access Platform-LH
- Extended canopy
- Eyebrow
- Fire extinguisher 9 kg 20 lb
- Heated body
- Hot start engine oil (220V 2-500W)
- Hot start hydraulic oil
- Hot start engine coolant (220V 2-2500W)
- Hubodometer
- Komatsu Smart Rims
- Komvision All-Around Monitoring System
- LED Headlights
- Mufflers between frame rails
- PLM IV® scoreboards
- Service center—RH
- Shutters (radiator)
- Spare Rim
- Spare Smart Rim
- Suspensions (cold weather)
- Rock Ejectors

AESS924-01

©2022 Komatsu America Corp.

AD009(POD)

09/22 (EV-1)

KOMATSU®

Note: All comparisons and claims of improved performance made herein are made with respect to the prior Komatsu model unless otherwise specifically stated.

www.komatsuamerica.com

Komatsu America Corp. is an authorized licensee of Komatsu Ltd. Materials and specifications are subject to change without notice

KOMATSU®, Komatsu Care® KOMTRAX® and KOMTRAX Plus are registered trademarks of Komatsu Ltd.

All other trademarks and service marks used herein are the property of Komatsu Ltd., Komatsu America Corp. or their respective owners or licensees.