

# KOMATSU

## **GD655-7**

Tier 4 Final Engine



**MOTOR GRADER**

GD655



Photos may include optional equipment.

**HORSEPOWER**

Net: 218 HP 163 kW  
Gross: 221 HP 165 kW

**OPERATING WEIGHT**

38,250 lb 17350 kg  
42,946 lb 19480 kg (with ripper)

**BLADE LENGTH**

14' 4.27 m

# WALK-AROUND

GD655-7



Photos may include optional equipment.

## HORSEPOWER

Net: 218 HP 163 kW  
Gross: 221 HP 165 kW

## OPERATING WEIGHT

38,250 lb 17350 kg  
42,946 lb 19480 kg (with rip-  
per)

## BLADE LENGTH

14' 4.27 m



## THE ROAD TO SUCCESS STARTS WITH KOMATSU

The GD655-7 features a SAA6D107E-3 Tier 4 Final Compliant Engine and when coupled to Komatsu's Dual Mode Transmission, operators benefit from maximum control while reducing fuel consumption by up to 15% when compared to the GD655-5.

Komatsu's Dual Mode Transmission utilizes both a torque converter and a direct drive clutch to achieve high tractive effort, inching ability, high ground speeds and low fuel consumption.

### Performance Features

- Dual mode transmission takes advantage of the torque multiplication and inching characteristics of a torque converter as well as the low fuel consumption and increased travel speed of a direct drive.
- Automatic engine stall prevention disengages direct drive and utilizes a torque converter preventing engine stall
- Economy and Power engine modes
- Spring applied, hydraulic-release parking brake with larger caliper diameter for increased capacity
- Long wheelbase optimizes fine grading performance and body stability while maintaining a 24.2 ft turning radius
- 25 degree articulation angle either direction
- Closed-center load sensing hydraulics system ensures predictable work equipment response, multi-functioning abilities, reduced noise, and reduced fuel consumption.
- New articulation stop-at-center feature automatically returns the machine to the articulation center line
- New shift lever and F-N-R switch to simplify shifting and shuttle operation
- New gearshift preset function allows for initial presets of forward/reverse shuttle gears
- Differential lock

### Komatsu Tier 4 Final Engine

- The SAA6D107E-3 engine reduces fuel consumption by up to 15% compared to the GD655-5
- Selective catalytic reduction (SCR) system
- Komatsu Diesel Particulate Filter with automatic active regeneration
- Hydraulically actuated Variable Geometry Turbocharger
- Hydraulically actuated Cooled EGR
- Komatsu auto idle shutdown reduces unnecessary idle time, reducing SMR, fuel consumption, and exhaust emissions
- SCR system includes a heated DEF tank, heated lines and a reversing pump to prevent DEF from freezing in the delivery lines.
- Precleaner, Turbo II

### Serviceability

- Hydraulically driven, reversible cooling fan
- Monitor based diagnostics
- Dust boots installed on control valves prevent contamination
- Ground level fueling and DEF access with no obstruction from ripper
- Fuel pre-filter and water separator
- Battery box location provides protection from dust and debris
- Battery disconnect switch can be locked for service

### Standard Features

- Air conditioner/heater
- KOMTRAX Level 5
- Blade-lift accumulators
- Circle slip clutch
- Cab mounted work lights
- Plug-and-Play for 3DMC<sup>2</sup> System including integrated fingertip control levers in the cab
- Hydraulic circuits plumbed to rear of machine for optional attachments
- 2D Cross slope with integrated controls and monitor display

### Structural / Quality Features

- Komatsu Harmony – all major components are designed and manufactured by Komatsu
- New reduced cab noise by fine tuning rigidity of driveline (72 dB(A) in cabin)
- Optimized lubrication circuit in transmission for increased durability
- Larger drive shaft for increased durability
- Strong front frame with added torsional strength
- High-tensile steel moldboard
- Steel backed, rubber clamps to keep hydraulic lines cleanly routed and reduce chafing
- Replaceable plastic wear plates on moldboard circle

### New Larger Operator's Cab

- ROPS/FOPS Level II
- New high-capacity seat design with air suspension
- Electronically heated and slanted rear window for added seat reclining capability
- Auxiliary jack for MP3 device and 2 x 12V sockets
- Bluetooth radio
- USB port
- New low-effort electronic proportional control levers
- New steering wheel and steering lever
- LCD monitor panel with enhanced capability
- Standard rearview monitoring system with separate color monitor
- Hexagonal cab design provides excellent visibility of the moldboard
- New fingertip control switches allows for operation of 2D cross slope and 3DMC<sup>2</sup> systems
- Operator presence monitoring system
- Fully adjustable armrest with power raise and lower
- Ground level secondary shut down switch



# PERFORMANCE FEATURES

## KOMATSU NEW ENGINE TECHNOLOGIES

### Tier 4 Final Engine

The Komatsu SAA6D107E-3 engine is EPA Tier 4 Final emissions certified and provides exceptional performance while reducing fuel consumption. Based on Komatsu proprietary technologies developed over many years, this diesel engine reduces nitrogen oxides (NOx) compared to the previous model.

### Technologies Applied to New Engine

#### Heavy-duty aftertreatment system

This new system combines a Komatsu Diesel Particulate Filter (KDPF) and Selective Catalytic Reduction (SCR). The SCR NOx reduction system injects the correct amount of Diesel Exhaust Fluid (DEF) at the proper rate, thereby decomposing NOx into non-toxic water vapor (H<sub>2</sub>O) and nitrogen gas (N<sub>2</sub>).

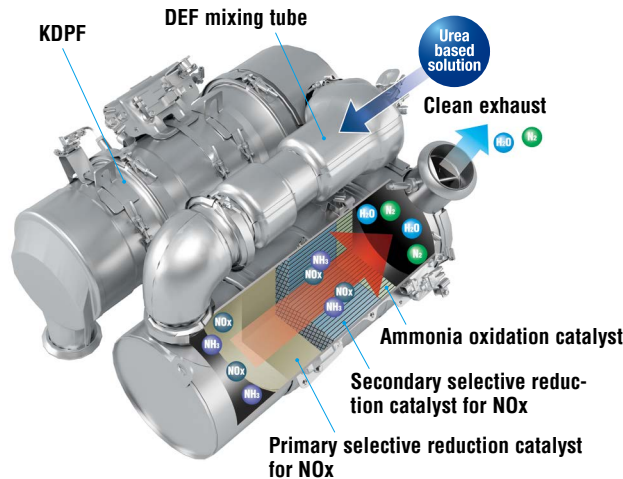

#### Heavy-duty cooled Exhaust Gas Recirculation (EGR) system

The system recirculates a portion of exhaust gas into the air intake and lowers combustion temperatures, thereby reducing NOx emissions. EGR gas flow has been decreased for Tier 4 Final with the addition of SCR technology. The system dramatically reduces NOx, while helping cut fuel

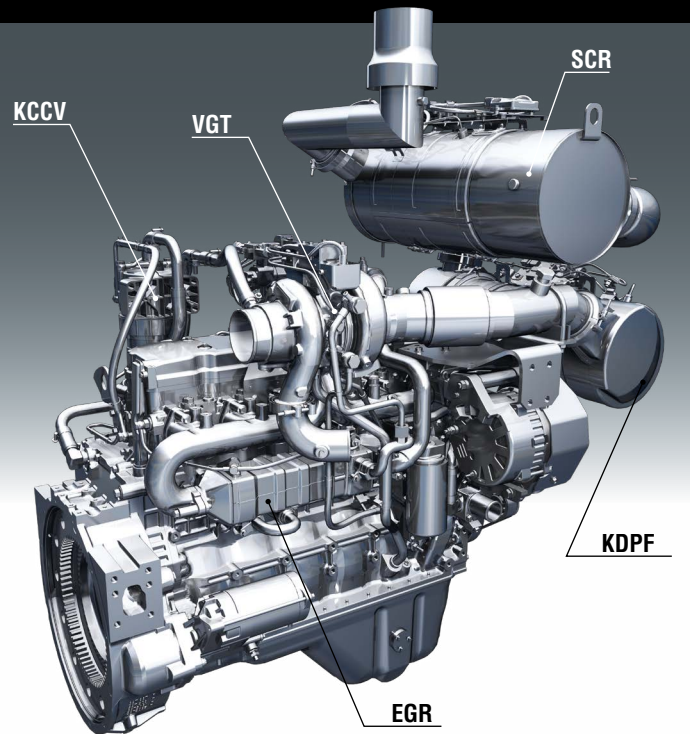
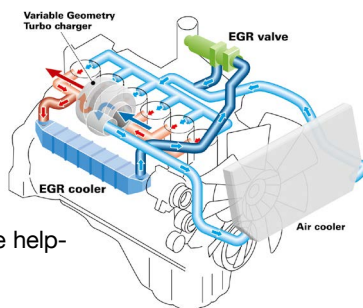

consumption below Tier 4 Interim levels.

#### Advanced Electronic Control System

The electronic control system performs high-speed processing of all signals from sensors installed in the vehicle providing total control of equipment. Engine condition information is displayed on the monitor inside the cab, providing necessary information to the operator. Additionally, managing the information via KOMTRAX helps customers keep up with required maintenance.

#### Variable Geometry Turbocharger (VGT) system

The VGT system features proven Komatsu design hydraulic technology for variable control of air-flow and supplies optimal air according to load conditions. The upgraded version provides better exhaust temperature management.

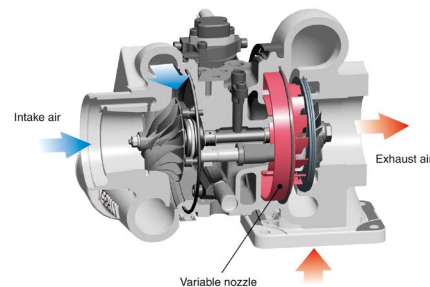

### Higher Productivity & Lower Fuel Consumption

A new variable displacement piston pump, improvements in the transmission and driveline components, and a sophisticated electronic control system for the engine and transmission all combine to achieve optimum and efficient operation. The new GD655-7 will consume up to 15% less fuel than the GD655-5. (The GD655-7 uses the same engine as the GD655-6)

#### Fuel consumption

**up to 5% reduction** (P mode)  
**up to 15% reduction** (E mode)

(Compared with GD655-5)

### Hydraulically Driven Cooling Fan

The engine cooling fan rotation speed is electronically controlled. This system increases fuel efficiency, reduces the operating noise levels, and requires less horsepower than a belt driven fan. The fan is manually reversible by the operator for periodic cleaning.

### Long Wheel base & Short Turning Radius

Longest wheelbase in class for exceptional fine grading performance. A 25 degree articulation angle left and right allows the GD655-7 to maintain a tight turning radius of 24'3" making this grader very maneuverable for tight road work and cul-de-sac operation.

### Komatsu Auto Idle Shutdown

Komatsu auto idle shutdown automatically shuts the engine down after idling for a set period of time to reduce unnecessary fuel consumption and exhaust emissions. Idle duration prior to shutdown can be easily programmed in the monitor. Feature can be turned off through the monitor and a time period of three to six minutes can be selected. Feature cancels by increasing engine rpm or moving the directional switch out of neutral position.

### Aggressive Moldboard Angles

A long wheelbase allows the operator to obtain an aggressive moldboard angle. This large blade angle permits material to roll more freely along the blade, which reduces power requirements. This is particularly helpful in dry soil, clay or for snow and ice removal.

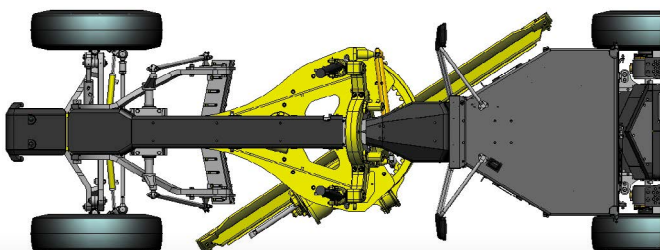

### Selectable Working Modes

The operator can choose between two working modes, Economy Mode or Power Mode, depending on their work demand and conditions.



#### Power mode



Greater productivity can be achieved by taking full advantage of high output power. P mode is appropriate for heavy grading applications.

#### Economy mode



E mode can be selected for reduced fuel consumption. E mode is appropriate when performing light and finish grading.

#### Marche avant kW (CV)

	Mode P		Mode E	
	AUTO	MANU	AUTO	MANU
F1	135	135	135	135
F2	(180)	(180)		
F3	150	150	135	135
F4				
F5				
F6				
F7	163	163	163	163
F8	(218)	(218)	(218)	(218)

#### Marche arrière kW (CV)

	Mode P		Mode E	
	AUTO	MANU	AUTO	MANU
R1	135	135	135	135
R2	(180)	(180)		
R3	150	150	135	135
R4	(200)	(200)		

# DUAL-MODE TRANSMISSION

## Komatsu Dual-mode Transmission

The dual-mode transmission is built specifically for Komatsu motor graders. The transmission provides full power shifting as well as inching capabilities and smooth automatic shifting in the higher ranges.

### Transmission Mode Selection

#### • Manual Mode

Transmission functions as a conventional direct drive with 8 forward speeds. Operators will benefit from consistent machine speed and reduced fuel consumption. When the control system senses an increase in load and determines that the engine is at risk of a stall condition, the direct drive clutch is automatically disengaged, allowing the power to be transferred through the torque converter, increasing tractive effort and preventing engine stall.

#### • Automatic Mode

When the gear is set to F1-F4, the transmission will remain in the desired speed range and utilizes the torque converter. The high tractive effort of the torque converter allows a start from stop in any range, F1-F4. Operators will enjoy the easy, 2 pedal (accelerator and brake) operation. In the higher ranges (F5-F8) the electronic control system will automatically shift the transmission from F4 to the selected speed range and automatically engage/disengage the lock-up torque converter as necessary.

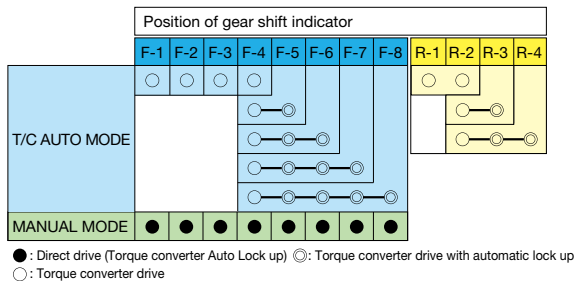

### Forward Reverse Inhibitor

If machine is traveling quickly it will automatically downshift to slow machine before directional change is made.

### Electronic over-speed protection

Helps prevent engine and transmission damage caused by premature downshifting and grade-induced over speeding.

### Electronic Transmission Control

The electronic control produces smooth shifting, which enables the operator to maintain a uniform grade while shifting. Automatic torque converter mode also extends the life of the transmission by reducing the shock loads in the transmission clutches. A new low effort electronic shift lever and easy to use forward-neutral-reverse switch is provided.

### Low Effort Inching Pedal

The inching pedal provides the operator precise control of machine travel at low speeds. This feature benefits all operators, but especially those accustomed to conventional, direct drive motor graders.



### Shift Lever and F-N-R Switch

The GD655-7 offers finger control shift lever and F-N-R switch near the right control levers. The operator can easily shift the gear and set direction during work equipment control.

### Gearshift preset function

F-N-R switch can set initial shift position to start, which reduces frequent shift lever operation during shuttle shifting.

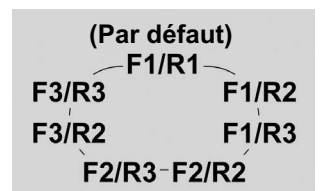

### Anti Stall Feature

Prevents engine stalling while in manual mode by automatically disengaging the lock up clutch and shifting to torque converter mode. The torque converter absorbs the load allowing the machine to keep moving and not stall or stop.

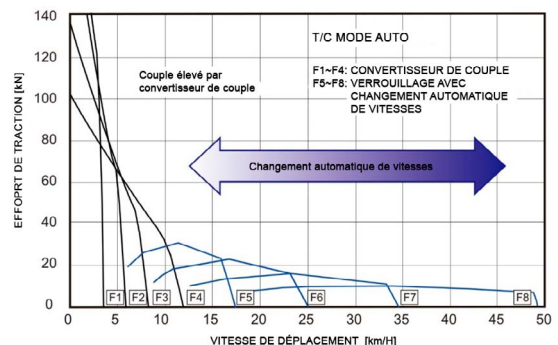
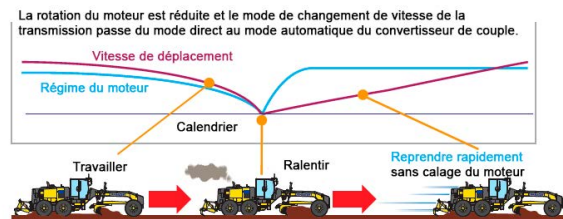

# ADVANCED CONTROL FEATURES

## Closed-center Load Sensing System (CLSS)

The variable displacement pump idles at low output. When it senses a load requirement, the pump supplies flow and pressure quickly to match the demand. The result is less hydraulic system heat, quick response and lower fuel consumption. The bottom line is greater efficiency with this Closed-center Load Sensing System (CLSS).

## New Articulation Stop-At-Center

A new feature from the previous model, the articulation stop-at-center feature can be turned on and allows the operator to be more efficient and productive. The articulation automatic return brings the machine back to center with just a movement of the articulation lever. This eliminates the need to operate additional switches or levers, and removes repetitive articulation to center correction by the operator.

## New Electronic Proportional Control Valves

Designed and built by Komatsu specifically for motor graders, the valves are direct acting and provide outstanding operator "feel" and predictable system response for precise implement control. To help maintain exact blade settings, lock valves are built into the hydraulic circuits. Relief valves are also incorporated into selected circuits to protect the cylinders from over-pressurization.

## Balanced Flow

When the operator uses several controls at the same time, flow is proportional to ensure several implements can operate simultaneously.

## Constant Implement Speed

Implement speed is constant regardless of engine speed because of the large pump output and proportional flow control function.

## PLUG-AND-PLAY FOR MMGPS AND 3DMC<sup>2</sup> GUIDANCE SYSTEM

The GD655-7 accepts TOPCON components without any additional modification to the hydraulic circuit. Just plug them in, and the machine control system provides complete control of the blade. The addition of the TOPCON system delivers higher productivity by generating more accurate results in less time, using less fuel and construction material.



## Integrated control levers

Operating switches for the machine control system are integrated with the work equipment lever. It provides convenient operational location and reduces modification of the lever while installing the equipment. Both the 2D cross slope system and the optional 3DMC<sup>2</sup> system can be controlled with these switches.

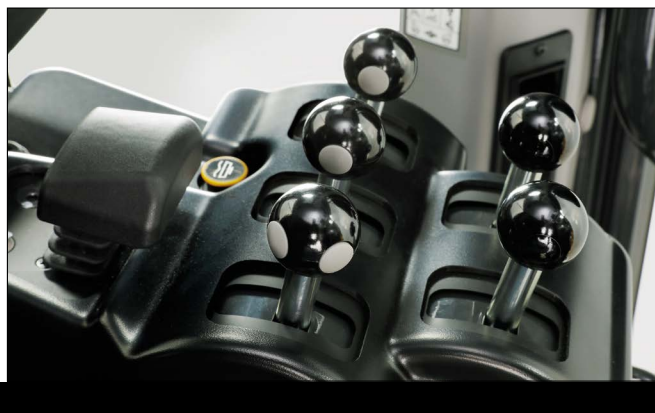

# OPERATOR ENVIRONMENT



## New Steering Wheel and Steering Lever

By moving the control console forward and backward, entry and exit from the cab becomes easy. The steering wheel also tilts to the operators preference.



## Visibility

Excellent visibility from the hexangular cab and layout of the rear side pillars boost operator confidence and productivity in all grader applications. Well-positioned blade linkage provides an unobstructed view of the moldboard and front tires.



## Less Effort

The new control system reduces operator arm movement, and relieves stress during operation.

## Movement of arm

Reduce up to **92%**

## Stress during operation

Reduce up to **10%**

Typical test data at Komatsu test center

## Fingertip Control

Short lever throws and low effort in both directions allows the operator to use multiple controls with one hand.



## Excellent Rear Visibility

The operator has an excellent view to the rear of the machine as well as the ripper.

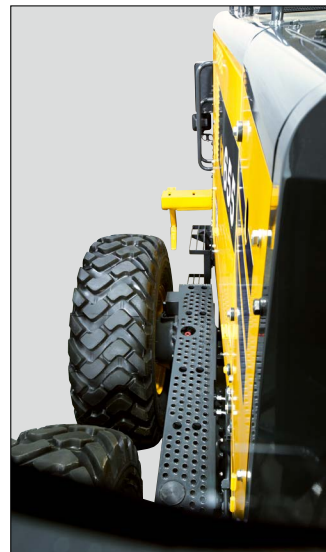

# STANDARD FEATURES

## Provisions for Auxiliary Hydraulic Circuit

This includes the control lever, valve section, and plumbing of hoses routed to the rear of the machine. If a customer decides at any point to install a ripper, this can be accomplished with an easy field install. Rippers are also available factory installed on the machine.

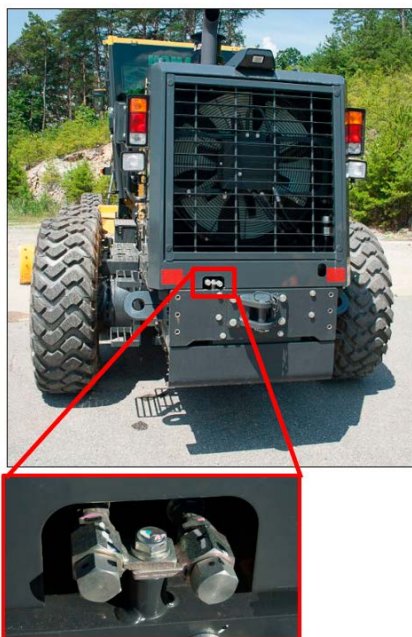

## Secondary Shut Down Switch

Ground level access to the secondary shut down switch on left hand side of machine when door is open.

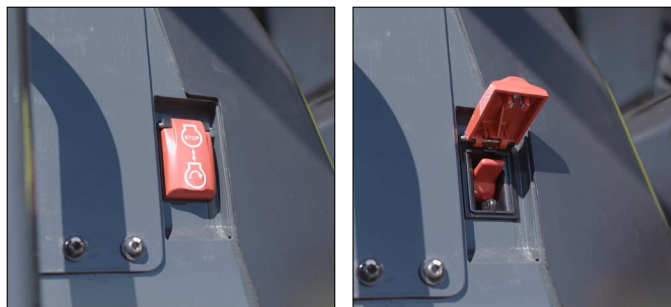

## Blade Lift-Circuit Accumulators

Pressurized hydraulic accumulators to help absorb impacts for high speed operation with lockable valve for fine grading operation.

COMMUNTEUR D'ACCUMULATEUR À LAMES



Accumulateur de levage de lame G.

## Engine Pre-Cleaner, Turbo II

The precleaner helps prevent contaminants from entering the engine intake. This extends air filter life, reduces engine wear, prolongs engine life, minimizes down time, and maintains effective engine breathing for maximum efficiency and power.



## Provisions for installation of mmGPS with 3DMC<sup>2</sup> Control System

All provisions necessary for installation of 3DMC<sup>2</sup> grade control system have been designed in from the factory. All mounting brackets and cable pass troughs required to install TOPCON grade control come standard on the GD655-7. This means that no additional hydraulic valve, and no cutting, welding, or drilling are required to install a grade control system.

## 2D Cross Slope Control System

There is a factory integrated 2D cross slope control system on the GD655-7. This system utilizes the main display monitor and integrated control switches mounted in the short throw levers to quickly and efficiently adjust and set cross slope to the desired blade angle from the operators seat. There is no need to perform a daily calibration before beginning operation. Just set the desired slope percentage or match a pre-existing slope and begin to grade.

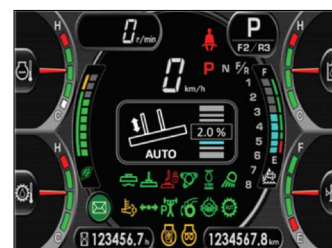

## Blade Circle Slip-Clutch

The blade circle slip-clutch helps absorb impacts from immobile objects that might damage moldboard or drawbar.



# STANDARD FEATURES

## ROPS/FOPS Cab

The low profile, enclosed cab offers a wide field of vision and roomy interior to reduce operator fatigue. The cab is ROPS/FOPS Level II (ISO 3471/ISO 3449) certified.



## Rear View Monitoring System

The operator can view the rear of the machine with a full color monitor that is located above the windshield. Visual guidelines can also be added for additional convenience.



## Low Noise

New hydraulically driven fan and redesigned layout of the cooling system provide a low noise level.

### Operator's ear dynamic noise level (ISO6396)

**72 dB (A)**

### Circumference dynamic noise level (ISO6395)

**108 dB (A)**

(Typical test data at Komatsu test center)



## Tie-Off Anchor Points

Anchor points mounted to ROPS frame roof provide secure locations for attaching fall protection harnesses.

## Seat Belt Warning Indicator

A warning indicator on the monitor appears when the seat belt is not fastened.

## New Suspension Seat

The air suspension, fabric covered seat which is adjustable to the operator's weight is provided as standard. The suspension seat dampens vibrations transmitted from the machine and reduces operator fatigue.

## Electric Throttle Control

An RPM set switch allows the operator to perfectly match ground speed to working conditions. The switch has three positions, auto, off, and manual. When the engine speed is set and the switch is positioned in Auto, the brake or acceleration pedal will temporarily override the RPM set point.

## Air Conditioner

Well-positioned air conditioning vents keep the cab temperature comfortable regardless of weather conditions.



## Standard Equipment

### Magazine box



Adjustable armrest with power raise and lower



### Bluetooth radio



### Lunch box tray



### Mobile phone tray



### Auxiliary input jack and USB port



# MAINTENANCE & DURABILITY FEATURES

## Easy Access to Service Areas

- Large hinged lockable doors are standard and provide easy access to the engine and radiator service points. Spin-on filters can be changed quickly.
- Circuits and fuse sizes are clearly identified in the fuse panel located in the cab.
- The tandem oil check point is conveniently located at the end of the tandem.
- Refueling from the ground is easy.
- Engine oil, hydraulic oil and coolant drains are positioned for easy maintenance.
- A tandem axle step is provided with a punched metal foot plate to ensure stable footing during maintenance and inspection.



Ground refueling



## Easy Access DEF Tank

The DEF tank is located at the rear of the machine and accessible from ground level. A lockable, hinged door prevents the need to open the hood during refilling. An external sight gauge aids in preventing overflow and spillage while refilling.

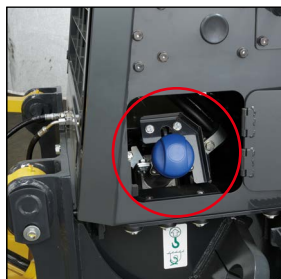

## Battery Lock-out Tag-Out Disconnect Switch

For inspection and maintenance, the batteries can be disconnected with the master disconnect switch.



## Battery Location

The battery box has been relocated to minimize dust accumulation.

## Metal Backed, Rubber Isolated Hose Clamps

Hydraulic hoses are routed and secured with metal backed, rubber isolating clamps to prevent vibrations, chafing, and damage.



## Double Seal, Blade Side Shift Cylinder

A double seal design has been adopted on the blade side shift cylinder given its proximity to the ground, making it susceptible to contamination.

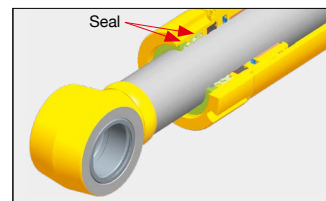

## Reinforced Blade Circle

The cross-sectional area of the circle has been increased to improve strength and durability. Structural changes to the drawbar and front frame also improve structural integrity and rigidity.



## Rugged Construction

The A-frame drawbar has a U-shape welded construction. A one-piece forged circle is built to stand up to high stress loads. To reduce wear, teeth are induction hardened in the front 180° of the circle. For maximum support, the circle is secured to the drawbar by six support shoes.

## Protection System

Blade circle slip clutch helps absorb impact when the moldboard contacts immovable objects. This feature is useful in applications where hidden objects are frequently encountered, as in rough grading and rocky areas. It helps prevent damage to drive gear teeth and moldboard rotation motor.

# KOMATSU PARTS & SERVICE SUPPORT



## KOMATSU CARE Program Includes:

\*The GD655-7 comes standard with complimentary factory scheduled maintenance for the first 3 Years or 2,000 Hours, whichever occurs first.

### Planned Maintenance Intervals at:

500/1000/1500/2000 hour intervals. (250 hr. initial interval for some products) Complimentary Maintenance Interval includes: Replacement of Oils & Fluid Filters with genuine Komatsu Parts, 50-Point inspection, Komatsu Oil & Wear Analysis Sampling (KOWA) / Travel & Mileage (distance set by distributor; additional charges may apply)

### Benefits of Using Komatsu CARE

- Assurance of Proper Maintenance with OEM Parts & Service
- Increased Uptime & Efficiency
- Factory Certified Technicians Performing Work
- Cost of Ownership Savings
- Transferable Upon Resale

## Komatsu CARE® – Extended Coverage

- Extended Coverage can provide peace of mind by protecting customers from unplanned expenses that effect cash flow
- Purchasing extended coverage locks-in the cost of covered parts and labor for the coverage period and helps turn these into fixed costs



## Komatsu Parts Support

- 24/7/365 to fulfill your parts needs
- 9 parts Distribution Centers strategically located across the U.S. and Canada
- Distributor network of more than 300 locations across U.S. and Canada to serve you
- Online part ordering through Komatsu eParts
- Remanufactured components with same-as-new warranties at a significant cost reduction



Interval PM	i250	500	1000	1500	2000
KOWA SAMPLING – engine and hydraulic only	✓				
CLEAN AC FRESH AND RECIRC AIR FILTERS	✓				
CHANGE TRANSMISSION CASE OIL	✓		✓		✓
CLEAN TRANSMISSION STRAINER	✓		✓		✓
CHANGE FINAL DRIVE CASE OIL	✓		✓		✓
REPLACE FINAL DRIVE BREATHER	✓		✓		✓
REPLACE HYDRAULIC OIL FILTER	✓		✓		✓
CHECK CIRCLE ROTATION GEAR CASE OIL	✓				✓
CHANGE TANDEM CASE OIL	✓				✓
LUBRICATE LINKAGE, JOINTS, & CYLINDERS	✓	✓	✓	✓	✓
CHECK AND CLEAN AIR CLEANER	✓	✓	✓	✓	✓
DRAIN SEDIMENT FROM FUEL TANK	✓	✓	✓	✓	✓
COMPLETE 50 POINT INSPECTION FORM; LEAVE PINK COPY WITH CUSTOMER OR IN CAB	✓	✓	✓	✓	✓
RESET MONITOR PANEL MAINTENANCE COUNTER FOR APPROPRIATE ITEMS	✓	✓	✓	✓	✓
KOWA SAMPLING – transmission, final drive, tandem(l & r), engine and hydraulic		✓	✓	✓	✓
CHANGE ENGINE OIL		✓	✓	✓	✓
REPLACE ENGINE OIL FILTER		✓	✓	✓	✓
REPLACE FUEL PREFILTER		✓	✓	✓	✓
REPLACE AC FRESH & RECIRC FILTERS		✓	✓	✓	✓
REPLACE FUEL MAIN FILTER			✓		✓
REPLACE TRANSMISSION OIL FILTER			✓		✓
REPLACE TRANSMISSION BREATHER			✓		✓
REPLACE DEF BREATHER			✓		✓
REPLACE HYDRAULIC TANK BREATHER			✓		✓
CHANGE HYDRAULIC OIL			✓		✓
CLEAN HYDRAULIC TANK STRAINER			✓		✓
REPLACE KCCV FILTER					✓
REPLACE DEF PUMP FILTER					✓
FACTORY TRAINED TECHNICIAN LABOR	✓	✓	✓	✓	✓

## Komatsu Oil and Wear Analysis (KOWA)

- KOWA detects fuel dilution, coolant leaks, and measures wear metals
- Proactively maintain your equipment
- Maximize availability and performance
- Can identify potential problems before they lead to major repairs
- Reduce life cycle cost by extending component life

\* Certain exclusions and limitations apply. Refer to the customer certificate for complete program details and eligibility. Komatsu® and Komatsu Care® are registered trademarks of Komatsu Ltd. Copyright 2019 Komatsu America Corp.

GD655-7

# KOMTRAX EQUIPMENT MONITORING

GET THE WHOLE STORY WITH  
**KOMTRAX**<sup>®</sup>

✓ **WHAT**

- KOMTRAX is Komatsu's remote equipment monitoring and management system
- KOMTRAX **continuously monitors and records** machine health and operational data
- Information such as fuel consumption, utilization, and a detailed history **lowering owning and operating cost**

✓ **WHEN**

- Know when your machines are **running or idling** and make decisions that will improve your fleet utilization
- Detailed movement records ensure you know when and where your equipment is moved
- Up to date records allow you to **know when maintenance is due** and help you plan for future maintenance needs

✓ **WHERE**

- KOMTRAX data **can be accessed virtually anywhere** through your computer, the web or your smart phone
- Automatic alerts keep fleet managers up to date on the latest machine notifications

✓ **WHY**

- Knowledge is power - **make informed decisions** to manage your fleet better
- Knowing your idle time and fuel consumption will help maximize your machine efficiency
- **Take control of your equipment** - any time, anywhere

✓ **WHO**

- KOMTRAX is **standard** equipment on all Komatsu construction products



**KOMTRAX**<sup>®</sup>

For construction and compact equipment.

**KOMTRAX Plus**<sup>®</sup>

For production and mining class machines.

# SPECIFICATIONS



## ENGINE

Model ..... SAA6D107E-3\*  
 Type ..... Water-cooled, 4-cycle, direct injection  
 Aspiration ..... Turbocharged, aftercooled, cooled EGR  
 Number of cylinders ..... 6  
 Bore ..... 107 mm **4.21"**  
 Stroke ..... 124 mm **4.88"**  
 Piston displacement ..... 6.69 L **408 in<sup>3</sup>**  
 Gross horsepower (Manual mode)  
 P-mode  
 Gear 1-3 ..... 136 kW **183 HP** / 2000 rpm  
 Gear 4-6 ..... 151 kW **203 HP** / 2000 rpm  
 Gear 7-8 ..... 165 kW **221 HP** / 2100 rpm  
 E-mode  
 Gear 1-6 ..... 136 kW **183 HP** / 2000 rpm  
 Gear 7-8 ..... 165 kW **221 HP** / 2100 rpm  
 Net horsepower (Manual mode)\*\*  
 P-mode  
 Gear 1-3 ..... 134 kW **180 HP** / 2000 rpm  
 Gear 4-6 ..... 149 kW **200 HP** / 2000 rpm  
 Gear 7-8 ..... 163 kW **218 HP** / 2100 rpm  
 E-mode  
 Gear 1-6 ..... 134 kW **180 HP** / 2000 rpm  
 Gear 7-8 ..... 163 kW **218 HP** / 2100 rpm  
 Max. torque ..... 941Nm 96.0 kgm **694 ft-lbs** / 1450 rpm  
 Torque rise ..... 30 %  
 Fan speed ..... Max. 1450 rpm  
 Air cleaner ..... 2-stage, dry-type  
 \* EPA Tier 4 Final emissions certified.  
 \*\* Net horsepower output for standard (SAE J1349) including air cleaner, alternator (not charging), water pump, lubricating oil, fuel pump, muffler and fan running at minimum speed.



## TRANSMISSION AND TORQUE CONVERTER

Full power shift transmission with integral free wheeling stator torque converter and lock-up.

Speeds (at rated engine speed)

Gear	Forward	Reverse
1st	3.8 km/h 2.4 mph	5.0 km/h 3.1 mph
2nd	5.5 km/h 3.4 mph	10.2 km/h 6.3 mph
3rd	7.7 km/h 4.8 mph	22.3 km/h 13.9 mph
4th	11.2 km/h 7.0 mph	44.4 km/h 27.6 mph
5th	16.9 km/h 10.5 mph	-
6th	24.5 km/h 15.2 mph	-
7th	33.7 km/h 20.9 mph	-
8th	48.5 km/h 30.1 mph	-



## TANDEM DRIVE

Oscillating welded box section ... 520 mm x 203 mm **1'8" x 8"**  
 Side wall thickness: Inner ..... 22 mm **0.87"**  
 Outer ..... 19 mm **0.75"**  
 Wheel axle spacing ..... 1525 mm **5'0"**  
 Tandem oscillation ..... 11° forward, 13° reverse  
 Tank ..... 7 L **1.8 U.S. gal**



## FRONT AXLE

Type ..... Solid bar construction welded steel sections  
 Ground clearance at pivot ..... 620 mm **2'0"**  
 Wheel lean angle, right or left ..... 16°  
 Oscillation, total ..... 32°



## REAR AXLE

Alloy steel, heat treated, full floating axle with lock/unlock differential.



## WHEELS, FRONT AND REAR

Bearings ..... Tapered roller  
 Tires ..... 17.5R25  
 Tire rims (dismountable) ..... 13" one-piece rims



## STEERING

Hydraulic power steering providing stopped engine steering meeting ISO 5010.  
 Minimum turning radius ..... 7.4 m **24'3"**  
 Maximum steering range, right or left ..... 49°  
 Articulation ..... 25°



## BRAKES

Service brake ..... Foot operated, sealed oil disc brakes, hydraulically actuated on four tandem wheels.  
 Parking brake ..... Manually actuated, spring applied, hydraulically released caliper.



## FRAME

Front Frame Structure  
 Height ..... 300 mm **11.8"**  
 Width ..... 300 mm **11.8"**  
 Upper, Lower ..... 25 mm **1.0"**



## DRAWBAR

A-shaped, u-section press formed and welded construction for maximum strength with a replaceable drawbar ball.  
 Drawbar frame ..... 210 x 22 mm **8.3" x 0.87"**



**CIRCLE**

Single piece rolled ring forging. Six circle support shoes with replaceable wear surface. Circle teeth hardened on front 180° of circle.

Diameter (outside) . . . . . 1530 mm **5'0"**  
 Circle reversing control hydraulic rotation . . . . . 360°



**MOLDBOARD**

Hydraulic power shift fabricated from high tensile steel. Includes replaceable metal wear inserts, cutting edge and end bits. Cutting edge and end bits are hardened.

Dimensions . . . . . 4270 x 580 x 25 mm **14' x 1'11" x 1"**  
 Arc radius . . . . . 432 mm **1'5"**  
 Cutting edge . . . . . 152 x 16 mm **6" x 0.63"**  
 Replaceable/Reversible side edges

. . . . . 456 x 156 x 16 mm **1'6" x 6" x 0.6"**

Blade pull

Base GVW . . . . . 10100 kg **22,267 lbs**  
 With ripper GVW . . . . . 11360 kg **25,045 lbs**

Blade down pressure

Base GVW . . . . . 6940 kg **15,300 lbs**  
 With ripper GVW . . . . . 8760 kg **19,313 lbs**



**BLADE RANGE**

Moldboard side shift:

Right . . . . . 625 mm **2'1"**  
 Left . . . . . 625 mm **2'1"**

Maximum shoulder reach outside rear tires (frame straight)

Right . . . . . 2480 mm **8'2"**  
 Left . . . . . 2590 mm **8'6"**

Maximum lift above ground . . . . . 480 mm **1'7"**

Maximum cutting depth . . . . . 615 mm **2'0"**

Maximum blade angle, right or left . . . . . 90°

Blade tip angle . . . . . 40° forward, 5° backward



**HYDRAULICS**

Load-sensing closed center hydraulics with variable displacement piston pump. Electronic proportional controlled valves with preselected maximum flow setting to each function. Double acting anti-drift check valves on blade lift, tip, circle shift, articulation, and leaning wheels.

Output (at engine rated rpm) . . . . . 203 L/min **53.6 U.S. gal/min**  
 Standby pressure . . . . . 3.4 MPa 35 kg/cm<sup>2</sup> **500 psi**  
 Maximum system pressure . . . . . 20.6 MPa 210 kg/cm<sup>2</sup> **3,000 psi**



**INSTRUMENT**

Electric monitoring system with diagnostics:

Gauges:

Standard: articulation, engine coolant temperature, fuel level, speed meter, transmission shift indicator, engine tachometer, torque converter oil temperature

Warning lights/Indicator:

Standard: battery charge, blade float, brake oil pressure, inching temperature, directional indicator, engine oil pressure, hydraulic oil temperature, heater signal, lift arm lock, parking brake, differential lock, torque converter oil, temperature, ecology, E-mode, fan reverse, rpm set, high beam, working lights



**CAPACITIES (REFILLING)**

Fuel tank . . . . . 390 L **103.0 U.S. gal**  
 Cooling system . . . . . 30 L **7.9 U.S. gal**  
 Crank case . . . . . 23 L **6.1 U.S. gal**  
 Transmission . . . . . 45 L **11.9 U.S. gal**  
 Final drive . . . . . 16 L **4.2 U.S. gal**  
 Tandem housing (each) . . . . . 57 L **15.1 U.S. gal**  
 Hydraulic system . . . . . 69 L **18.2 U.S. gal**  
 Circle reverse housing . . . . . 7 L **1.8 U.S. gal**  
 DEF Tank . . . . . 36 L **9.5 U.S. gal**



**OPERATING WEIGHT (APPROXIMATE)**

Includes lubricants, coolant, full fuel tank

Total . . . . . 17350 kg **38,250 lbs**

With rear mounted ripper and front push plate:

Total . . . . . 19480 kg **42,946 lbs**



**RIPPER**

Ripping depth, maximum . . . . . 425 mm **1'5"**  
 Ripper shank holders . . . . . 5  
 Ripper shank holder spacing . . . . . 534 mm **1'9"**  
 Penetration force . . . . . 9650 kg **21,275 lbs**  
 Pryout force . . . . . 16600 kg **36,597 lbs**  
 Machine length increase, beam raised . . . . . 690 mm **2'5"**



**SCARIFIER**

Middle, V-type

Working width . . . . . 1430 mm **4'8"**  
 Scarifying depth, maximum . . . . . 190 mm **7.5"**  
 Scarifier shank holders . . . . . 11  
 Scarifier shank holders spacing . . . . . 138 mm **5.4"**

Rear

Working width . . . . . 2186 mm **7'2"**  
 Scarifying depth, maximum . . . . . 165 mm **6.5"**  
 Scarifier shank holders . . . . . 9  
 Scarifier shank holders spacing . . . . . 267 mm **10.5"**

# SPECIFICATIONS



## DIMENSIONS

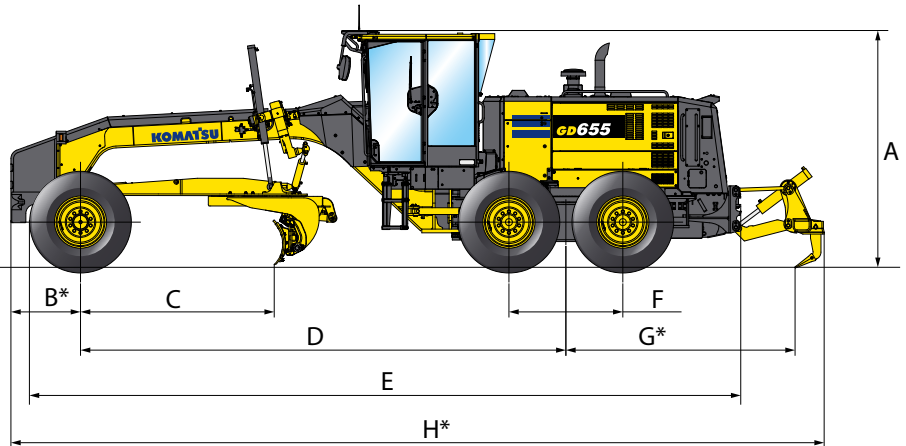
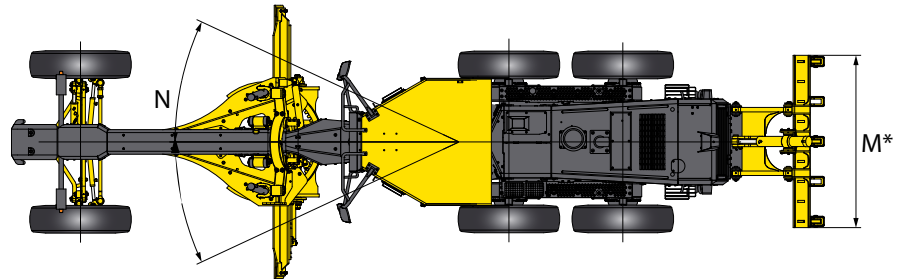
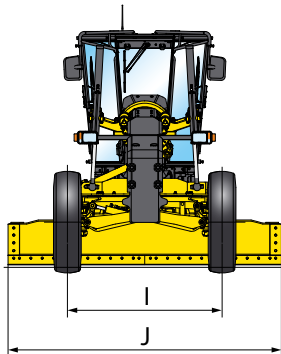
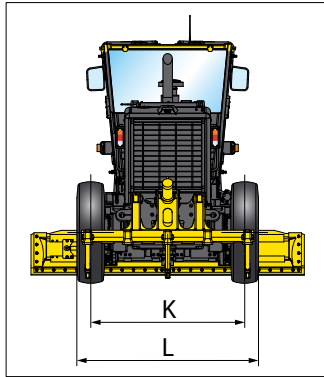

<b>A</b>	Height: Low profile cab	3200 mm	<b>10'6"</b>
<b>B*</b>	Center of front axle to counterweight (Pusher)	930 mm	<b>3'1"</b>
<b>C</b>	Cutting edge to center of front axle	2580 mm	<b>8'6"</b>
<b>D</b>	Wheelbase to center of tandem	6495 mm	<b>21'4"</b>
<b>E</b>	Front tire to rear bumper	9510 mm	<b>31'2"</b>
<b>F</b>	Tandem wheelbase	1525 mm	<b>5'0"</b>
<b>G*</b>	Center of tandem to back of ripper	3065 mm	<b>10'1"</b>
<b>H</b>	Overall length	10875 mm	<b>35'8"</b>
<b>I</b>	Tread (front)	2170 mm	<b>7'1"</b>
<b>J</b>	Width of standard moldboard	4270 mm	<b>14'0"</b>
<b>K</b>	Tread (rear)	2160 mm	<b>7'1"</b>
<b>L</b>	Width over tires	2680 mm	<b>8'9"</b>
<b>M*</b>	Ripper beam width	2305 mm	<b>7'7"</b>
<b>N</b>	Articulation, left or right	25°	

\* : optional



**STANDARD EQUIPMENT FOR BASE MACHINE**

**Engine and its related items:**

- Accelerator and electric throttle control
- Air cleaner, double element with dust indicator
- Air intake extension
- Antifreeze -22 F(-30C)
- Auto-idle Shutdown
- Hydraulic driven, reversing, cooling fan, blower type, plastic blade, with fan guard
- Engine, Komatsu SAA6D107E-3, 145 to 218 VHP EPA Tier 4 Final certified, turbocharged and air-air after cooled
- Fuel line pre-filter
- KDPF - After-Treatment Assembly Consisting of KDOC and KCSF
- Pre-cleaner
- Secondary Engine Shutdown Switch
- Selective Catalytic Reduction (SCR) System

**Electrical system:**

- Alarm, backup
- Alternator, 140 Ampere, (24V)
- Batteries, Extreme duty, 2 x 12V, 1146 cca each
- Battery, disconnect switch with lockout-tagout
- Dome light cab
- Headlights,(2) halogen type, front bar mounted
- Horn, electric
- Indicator lights:
  - Battery charge
  - Blade float
  - Brake oil pressure
  - Cooling fan reverse mode
  - Differential lock
  - Differential oil temperature
  - Dual power mode, economy and power
  - Engine oil pressure
  - Engine RPM set
  - Lift arm lock
  - Lights, high beam

- Parking brake
- Transmission system electrical circuit
- Lights: backup, stop, directional, tail
- Operator presence monitoring system
- Starter 5.5kW
- Working light, front(4) and rear(2)
- Working light ,(4)cab mounted flood type

**Operator environment:**

- 12V (10A) power port
- Adjustable air suspension seat
- Adjustable tilt/telescopic steering wheel
- Air conditioner (R134a) with heater
- AM/FM Bluetooth radio with aux input and USB port
- Cab: low profile with ROPS/FOPS Level II (SAE J1040, J2311)
- Console, adjustable with instrument panel monitoring system
- Electric defroster rear window
- Electronic height adjustable LH and RH consoles
- Mirrors: interior cab, right and left exterior mirrors
- Multi-monitor with 7" LCD Display
- Rearview Camera and Monitor
- Sound suppression, 72 DbA at operators ear with floor mat with tinted windows, front, rear and door intermittent wiper/washers

**Power train:**

- Dual mode transmission (8F-4R) power shift direct drive and torque converter with auto shift
- Electronic gear shift lever
- Axle, rear full floating, planetary type reduction
- Service brakes, fully hydraulic wet disc
- Parking brake, spring apply, hydraulic release dry disc
- Differential, manual lock/unlock
- Tires and rims: 17.5R25 radials on one-piece 13" rims (6)
- Transmission underguard

**Work equipment and hydraulics:**

- Articulation stop-at-center
- Blade accumulators
- Blade lift float, detent type, LH and RH
- Circle, drawbar mounted, 360° rotation with blade lift and circle side shift with anti-drift check valves
- Circle slip clutch
- Low-effort electronic proportional control levers (joysticks)
- Greaseless circle wear plates
- Hydraulic control valve, 2-5 valve sections
- Hydraulic system, closed center, load sensing
- Steering, full hydraulic with tilt steering wheel plus leaning front wheels and frame articulation with anti-drift check valves. Steering lever/ joystick provided

**Other standard equipment:**

- Anchor points for secure tie-off
- Provisions for rear hydraulic ripper
- Battery cover and engine side covers
- Integrated 2D cross slope system
- Komtrax - Level 5
- Precleaner, Turbo II
- Provision for Grade Control, TOPCON
- Rear hitch
- Steps and handrails, right, left and rear
- Toolbox with lock
- Vandalism protection, lockable fuel tank, hydraulic tank, battery cover, engine side covers



**OPTIONAL EQUIPMENT**

- 610 mm 2' LH/RH moldboard extensions
- Moldboard: 3710 mm x 660 mm x 22 mm 12' x 26" x 0.87" with replaceable end bits, 152 mm x 16 mm 6" x 0.63" through-hardened cutting edges and 5/8" hardware
- Pusher plate (for use with rear mounted ripper/scarifier assembly)
- Moldboard extensions
- Mid-mounted scarifier assembly (includes 11 shanks and replaceable points)
- Rear-mounted ripper/scarifier assembly includes (3) shanks or (9) scarifier shanks can be inserted into the available slots
- Winter tires with three piece rims



Scarifier



Ripper

# NOTES

GD 655-7





*Note: All comparisons and claims of improved performance made herein are made with respect to the GD655-6 unless otherwise specifically stated. The GD655-6 & -7 share the same engine, transmission, frame, and other components.*