



D37EX/PX-24

crawler dozer



Net horsepower

89 HP (66 kW) @ 2,200 rpm

Operating weight

D37EX-24: 19,842 lbs. (9,000 kg)

D37PX-24: 20,503 lbs. (9,300 kg)

Blade capacity

Power angle tilt (PAT) dozer

D37EX-24: 2.50 yd³ (1.91 m³)

D37PX-24: 2.79 yd³ (2.13 m³)

Power, agility and precision that's easy to transport

When your job demands a transportable dozer that delivers power plus precise grading, the D37 may be the answer. Your operators enjoy excellent blade visibility, agility and comfort. You get versatility for construction site work, high-speed grading and more.



Photos in this brochure may show optional equipment.

Net horsepower
89 HP (66 kW) @ 2,200 rpm

Operating weight
D37EX-24: 19,842 lbs. (9,000 kg)
D37PX-24: 20,503 lbs. (9,300 kg)

Blade capacity
Power angle tilt (PAT) dozer
D37EX-24: 2.50 yd³ (1.91 m³)
D37PX-24: 2.79 yd³ (2.13 m³)

SAA4D95LE-7 variable flow turbocharged and after-cooled 3.26 liter diesel engine provides excellent fuel economy. This engine is EPA Tier 4 Final emissions certified.

Water-cooled variable flow turbocharger uses a simple valve to provide optimum air flow under all speed and load conditions.

Komatsu Diesel Oxidation Catalyst (KDOC) and selective catalytic reduction (SCR) systems reduce particulate matter and NOx using passive regeneration 100% of the time. No active or manual regeneration is required.

Komatsu auto idle shutdown helps reduce excessive idle time.

Rearview monitoring system (standard)

Advanced diagnostic system continuously monitors machine operation and vital systems to identify machine issues, assists with troubleshooting, and minimizes downtime.

Single pedal can act as either decelerator or brake.

Efficient cooling system:

- Electronically controlled, hydraulically driven fan is manually reversible
- Rear hinged radiator guard with gas-assisted lift cylinders, opens easily for cleaning
- Side-by-side coolers provide single plane to reduce chances of plugging

Komatsu telematics solutions: Telematics data can drive results for business operations, but only when you can collect and analyze it efficiently. We've designed a system that makes it easy to collect, visualize and monitor telematics data from both Komatsu machines and other OEM machines.

My Komatsu, our comprehensive digital hub, analyzes telemetric data from your on-machine technology — Komtrax and Komtrax Plus, or ISO API 15143-3 (AEMP 2.0) data from other OEMs — and displays it on easy-to-read dashboards. Now you can finally get the powerful analytics you need to manage your costs and enhance your fleet's efficiency without a complicated process or expensive third-party solutions.

Operator identification system (standard) can be monitored through Komtrax

Integrated ROPS cab features:

- Large, quiet, pressurized cab
- Exceptional visibility with super slant nose design and integrated ROPS structure
- Heated air-ride seat with high-capacity suspension (standard)
- Standard aux jack and two 12-volt power convertors

Improved durability:

- Heavy-plate steel used for nose and tanks
- Dozer frame with full steel castings
- Komatsu-designed and manufactured components



Self-adjusting idler support provides constant and even idler tension, reducing vibration and increasing undercarriage life.

Parallel Link Undercarriage System (PLUS) provides up to double the wear life and lowers repair and maintenance costs compared to a standard undercarriage design.

Triple labyrinth final drive provides additional protection for the final drive floating seals.

Power Angle Tilt (PAT) dozer with manually adjustable blade pitch increases productivity in a variety of applications.

Complete operator blade control:

- Palm Command Control System (PCCS)
- Electronic Proportional Control (EPC)
- Adjustable quick shift and variable shift modes
- Blade angle switch
- New three blade control settings
- Up to five individual operator memory settings

Efficient hydrostatic transmission with electronic control:

- Customizable quick shift (three speed) settings for the operator
- Variable speed selection (20 speeds)
- Low speed matching technology (larger displacement pumps/efficient engine speed)
- HST control system reduces fuel consumption

Large color monitor:

- Easy-to-read and use large 7" high-resolution multi-color LCD monitor
- Ecology guidance
- Easy-to-use onboard diagnostics that don't require a laptop
- Real-time DEF monitoring so the operator can see actual DEF levels

Performance features

Komatsu's emission regulations-compliant engine

New regulations effective in 2014 require the reduction of NOx emissions. In addition to refining the Tier 4 Interim technologies, Komatsu developed a new selective catalytic reduction (SCR) device in-house.

- 1 Komatsu diesel oxidation catalyst (KDOC)
- 2 Variable flow turbocharger
- 3 Komatsu closed crankcase ventilation (KCCV)
- 4 Selective catalytic reduction (SCR)

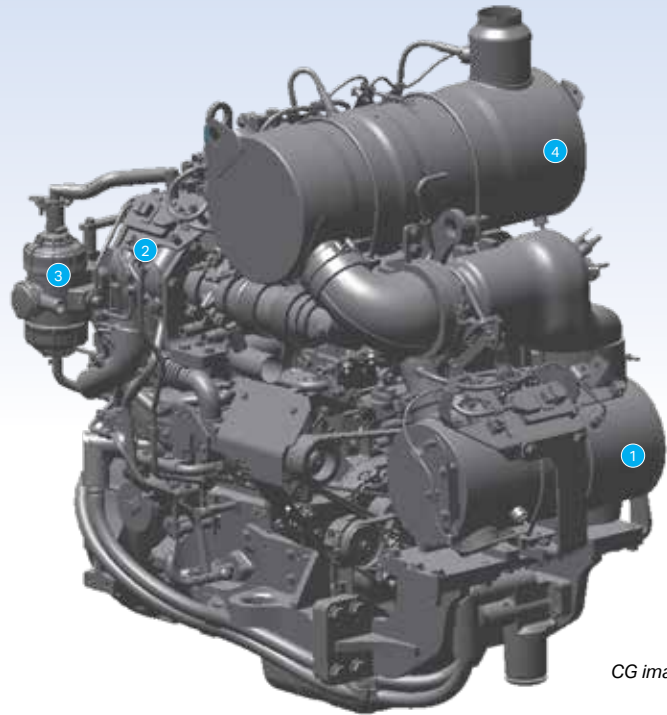

CG image

Technologies applied to the engine

Water-cooled variable flow turbocharger

A variable flow turbocharger features simple and reliable technology that varies the intake air-flow. Exhaust turbine wheel speed is controlled by a flow control valve that enables delivery of an optimal volume of air to the engine combustion chamber under all speed and load conditions. The result is cleaner exhaust gas while maintaining power and performance.

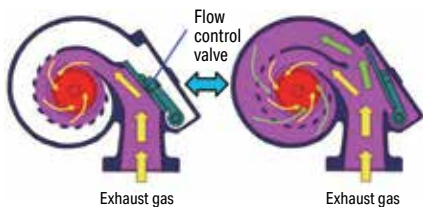

Heavy-duty aftertreatment system

This system consists of a Komatsu diesel oxidation catalyst (KDOC) and a selective catalytic reduction (SCR). The SCR NOx reduction system injects the correct amount of DEF at the proper rate, transforming NOx into non-toxic water (H₂O) and nitrogen gas (N₂).

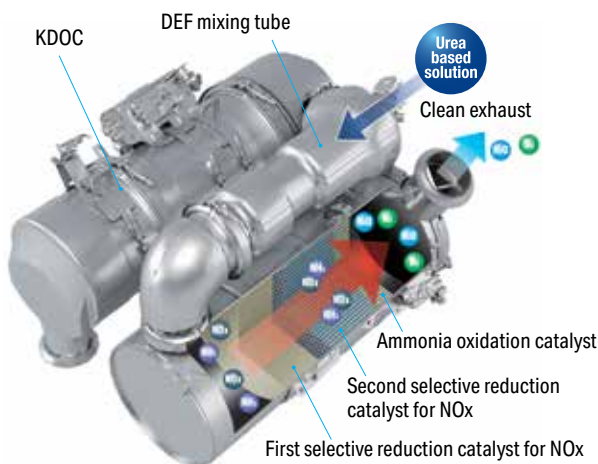

Cooled exhaust gas recirculation (EGR)

Cooled EGR, a technology well-proven in existing Komatsu engines, reduces NOx emissions. These components ensure reliable performance during the demanding work conditions of construction equipment.

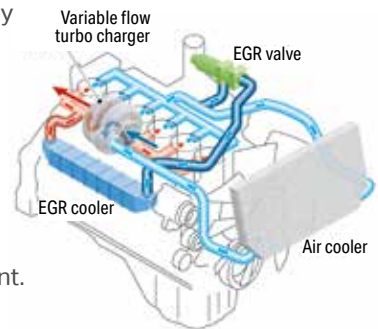

Komatsu closed crankcase ventilation (KCCV)

Crankcase emissions (blowby gas) are passed through a KCCV filter. The KCCV filter traps oil mist which is returned back to the crankcase while the gas, which is almost oil mist free, is fed back to the air intake.



Heavy-duty high-pressure common rail (HPCR) fuel injection system

The system is designed to achieve an optimal injection of high-pressure fuel by means of computerized control, providing close-to-complete combustion to reduce PM emissions. The system uses high pressure injection, thereby reducing both PM emissions and fuel consumption over the entire range of engine operating conditions. The Tier 4 Final engine has advanced fuel injection timing for reduced fuel consumption and lower soot levels.

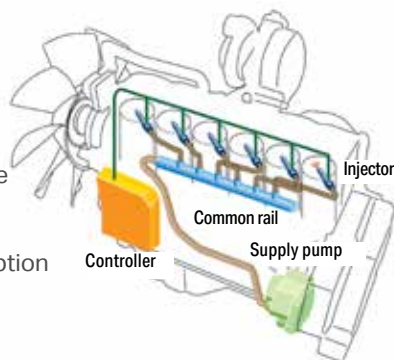

Advanced electronic control system

The electronic control system performs high-speed processing of all signals from sensors installed in the vehicle and engine, allowing the operator to maintain control of the equipment even in challenging conditions. Engine condition information is displayed via an onboard network on the monitor inside the cab. Furthermore, Komtrax helps customers use this information to keep up with maintenance needs.

Redesigned combustion chamber at top of piston

The combustion chamber at the top of the piston has a new shape designed to improve combustion and further reduce NOx, PM, fuel consumption and noise.

Auto idle shutdown function

Komatsu auto idle shutdown automatically shuts the engine down after idling for a set period of time to reduce unnecessary fuel consumption and exhaust emissions. The amount of time before the engine is shutdown can be easily programmed from 5 to 60 minutes.



Productivity and fuel economy features

Hydrostatic transmission (HST) control system

The HST controller monitors engine output and work load. It controls HST pump and motor displacement to provide the optimum speed and drawbar pull. Full power to both tracks during turns or counter-rotation makes the D37EX/PX-24 extremely maneuverable.



Fuel efficiency

The efficient HST control system can reduce fuel consumption.

Fuel consumption reduced by up to **5%**

Compared with D37EX/PX-23 in P mode
Based on typical work pattern collected via Komtrax

Hydraulically driven cooling fan

The engine cooling fan's speed is electronically controlled. The fan speed depends on engine coolant, oil temperatures and the fan will only rotate as fast as is necessary to adequately cool the machine's fluid. This system increases fuel efficiency, reduces the operating noise levels and requires less horsepower than a belt-driven fan.

Selectable working mode

P mode is the mode designed for powerful operation and maximum production. E mode is designed for general dozing applications, providing adequate speed and power, while saving energy. H mode is designed in comparison to P mode, but with a higher RPM. For fuel reduction and energy savings, the monitor panel allows the operator to easily switch between working modes, depending on working conditions.

P mode (power mode)

With P mode, the engine outputs its full power, allowing the machine to perform work requiring large production, heavy-load, and uphill work.

E mode (economy mode)

With E mode, the engine outputs enough power for the work without delivering unnecessary power. This mode enables energy-saving operation and is ideal on hard or rough surfaces that often cause shoe slip and work not requiring as much power, such as downhill dozing, leveling and light-load work.

H mode (high engine idle speed mode)

H mode is installed to only North American specification. Compared with the P mode, the engine high idle speed is higher in the H mode. This setting allows subtle changes in load to be detected, which is suitable for power-intensive work.

Moldboard PAT dozer with adjustable pitch

A high wear-resistant power angle, power tilt dozer blade with adjustable blade pitch is available on the D37EX/PX-24. The hydraulic blade tilt and angling function expands versatility and productivity in a variety of applications.

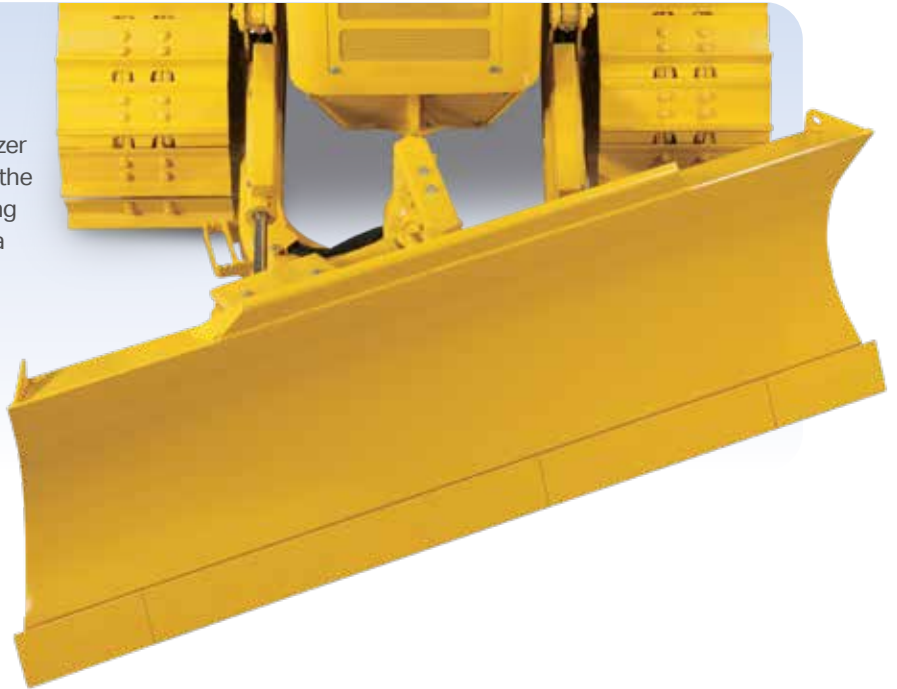

Looking for a clear line of sight? Let us help you see what you're missing!

Features:

- Rear-mounted radiator
- Enhanced cab-forward design with integrated ROPS
- Super slant-nose engineering

Benefits:

- Improved visibility: Rear radiator placement allows for a lower front height
- Operator confidence: Enhanced field of view facilitates safe practices
- Comfortable: Superior cab-forward design for a balanced ride

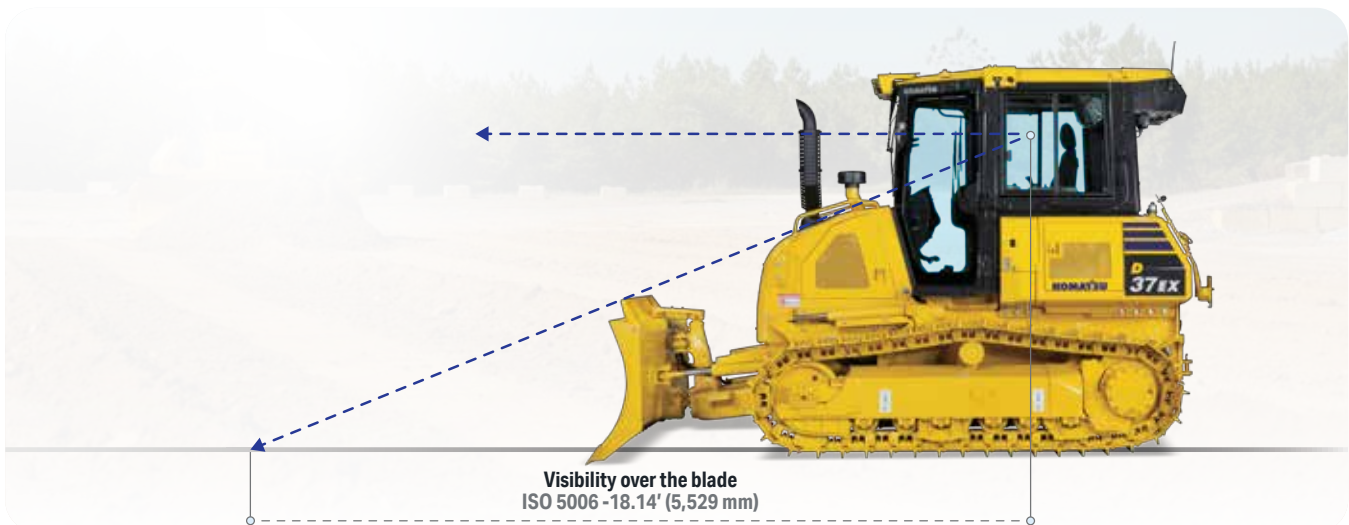

Control features



Palm command control system (PCCS) levers

Komatsu's ergonomically-designed PCCS handles create an operating environment designed for complete operator control.

PCCS

The low-effort PCCS joystick controls all directional movements, including machine travel speed as well as counter-rotation.

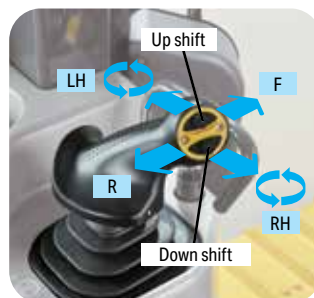

Electronic-controlled hydraulic system

The electronic-controlled, palm commanded joystick provides precise blade control. New blade angling switch operation provides easier and predictable blade control.

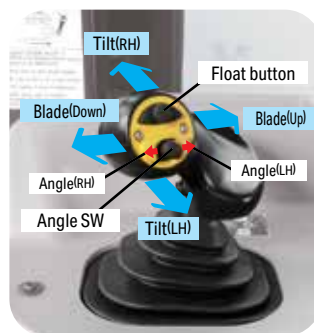

HST with electronic control

The D37EX/PX-24 is equipped with Komatsu-designed HST that allows for quick-shift or variable speed selection. The HST consists of dual-path closed-circuits, with two variable displacement piston pumps and two variable displacement travel motors. Hydrostatic steering eliminates steering clutches and brakes, providing smooth, powerful turns. Fully electronic control provides complete automatic shifting and enables smooth control. Engine speed is controlled using an electronic fuel control dial.

One-pedal design (decelerator/brake pedal) controls speed, during operation

Machine operation is simple due to brake function integration into the decelerator pedal. Machine travel speed can be controlled using one pedal. The pedal function can be changed by a mode selector switch.

Decelerator mode: The pedal can decelerate engine rpms and vehicle travel speed. It can be used for all applications.

Brake mode: The pedal can decelerate vehicle travel speed while maintaining high-engine speed. This mode can be helpful to maintain work-equipment speed, while using the brake function.



Working environment

Integrated ROPS (ISO 3471) cab

The D37EX/PX-24 has an integrated ROPS (ISO 3471) cab. High rigidity and superb sealing performance sharply reduce noise and vibration for the operator and discourage dust from entering the cab. In addition, side visibility is increased because external ROPS (ISO 3471) structure and posts are not required.



Comfortable ride with cab damper mounting

The D37EX/PX-24's cab mount uses a cab damper system that provides shock and vibration absorption conventional mounting systems cannot match. The silicon-oil-filled cab damper mount helps to isolate the cab from the machine body, suppressing vibration and providing a quiet, comfortable operating environment.

Auxiliary input jack and two electrical outlets

By connecting an auxiliary device to this plug input, the operator can play audio from a mobile device through the machine's sound system. Two DC 12-volt electrical outlets provide a power source for a radio or other equipment.

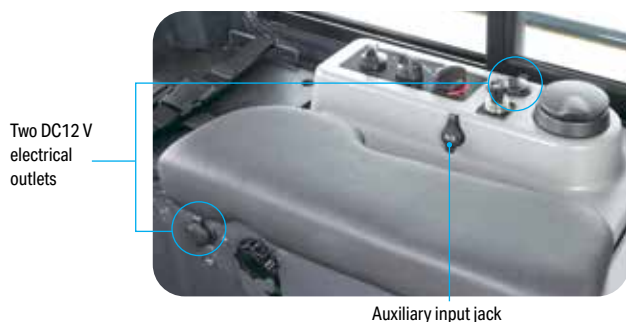

Comfortable ride with heated operator seat

The operator seat has adjustable lumbar support, tilt and an electric heater. It is easy to adjust to the operator's shape. Also, standard seat heat makes it possible to work comfortably in cold temperatures.



Additional operator convenience equipment

Rearview monitor system

On the large LCD color monitor, the operator can view, through one camera, areas directly behind the machine. This camera can be synchronized with reverse operation.



Secondary engine shutdown switch

A secondary switch has been added at the side of the front console to shut down the engine.



Reliability and maintenance features

Excellent reliability and durability

Parallel Link Undercarriage System (PLUS)

Komatsu's PLUS provides less downtime plus longer wear with up to 40% lower undercarriage maintenance costs. Rotating bushings eliminate the cost and downtime for bushing turns, and strengthened rollers and links increase wear life up to two times. With PLUS, individual links can be replaced with common track tools.

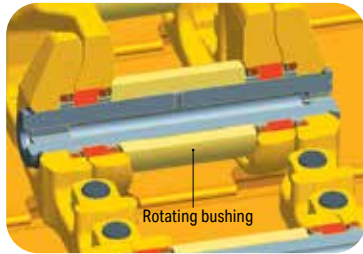

Modular design

One of the design goals behind the creation of the D37EX/PX-24 was to manufacture a more durable machine. This was achieved by reducing component complexity and using a strong modular design for increased serviceability and durability.



Self-adjusting idler support

The self-adjusting idler support provides constant and even tension on idler guide plates reducing noise and vibration and increasing undercarriage life.



Easy maintenance

Planned maintenance and daily checks are the only way to ensure long service life from equipment. That's why Komatsu designed the D37EX/PX-24 with conveniently located maintenance points to make necessary inspections and maintenance quick and easy.

Rear, hydraulically driven, swing-up fan

The D37EX/PX-24 utilizes a swing-up fan with a gas strut-assisted lift system to provide easy access to the (side-by-side) radiator, oil cooler and charge air cooler. The hydraulic fan has a cleaning mode which enables the fan to rotate in the reverse direction to help clear off objects that could restrict air flow.



Technology features

Large multi-lingual high-resolution LCD monitor

A large, user-friendly color monitor provides easy-to-understand information for the operator. Excellent screen visibility is achieved with a high-resolution LCD monitor that is easy to read at various angles and lighting conditions. Easy-to-operate switches and function keys simplify multi-function operations. The monitor displays data in 26 languages.

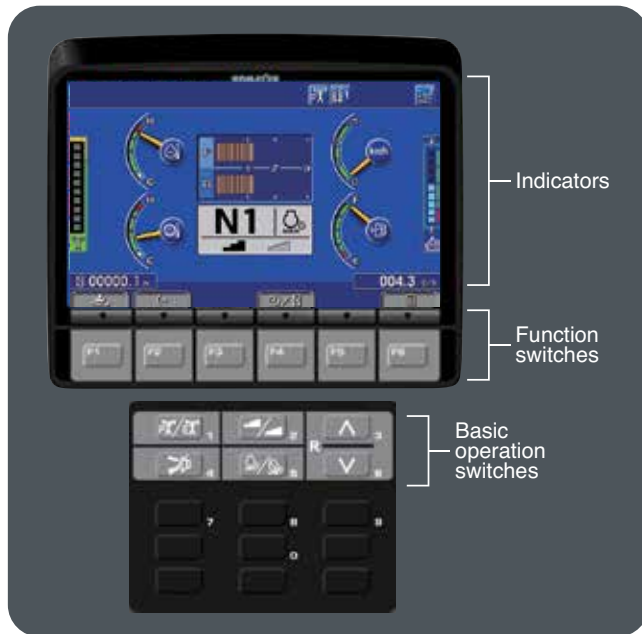

Multi-monitor with troubleshooting function to minimize downtime

Various meters, gauges and warning functions are centrally arranged on the multi-monitor. The monitor simplifies start-up inspection and promptly warns the operator with a lamp and buzzer if any abnormalities occur. In addition, counter-measures are indicated in four levels to help prevent major machine issues. Replacement times for required planned maintenance services are also indicated.



Energy-saving operation

Ecology guidance

In order to support efficient operation, the following four messages are displayed for fuel-saving operation. These can be disabled by the operator, if desired.

- 1) Avoid excessive engine idling
- 2) Use economy mode to save fuel
- 3) Avoid hydraulic relief pressure
- 4) Avoid over load

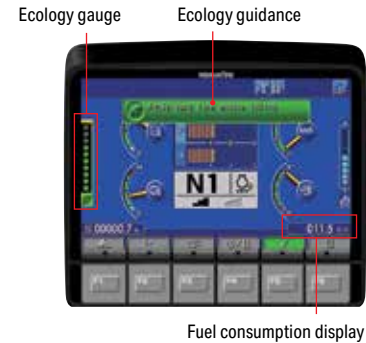

Ecology gauge

To help the operator perform more efficiently and minimize energy consumption, an easy-to-read ecology gauge is displayed on the left of the multi-monitor screen.

Fuel consumption display

Average fuel consumption during the day is displayed and updated every 10 seconds.

Enhanced blade mode

Blade tilt mode*

- Fast** Blade tilt speed is faster than normal mode, good for higher-speed spreading and fine grading.
- Normal** Blade response of tilt is optimized for general operations.
- Fine** Blade tilt speed is smoother and slower than normal mode, good for precise blade response when cutting bigger blade loads at lower speeds.

Blade lift mode*

- Fast** Blade raise and lower speed becomes faster than normal mode for use in short cycle work.
- Normal** Blade response of raise and lower is optimized for general operations.
- Fine** Blade raise and lower speed is smoother than normal mode for less shock in longer cycle work.

*Blade response can be changed on the mode select screen.

Komatsu helps you bring it all together

Get the most out of your fleet on My Komatsu

We've designed a portal that makes it easy to collect, visualize and monitor data for both Komatsu machines and other OEM machines. My Komatsu also gives you one easy source for accessing manuals and purchasing parts for your machines.

- Quickly collect, view and manage intuitive data displays in one location
- Help keep costs under control
- Benchmark machine performance and track fuel consumption
- Monitor for theft and unauthorized use
- Receive timely maintenance alerts



My Komatsu, our comprehensive portal, analyzes telematics data from your on-machine technology — Komtrax and Komtrax Plus, or from other OEMs — and displays it on easy-to-read dashboards. Now you can get the powerful analytics you need to manage your costs and enhance your fleet's efficiency without a complicated process or expensive third-party solutions.



Data

Telematics data is generated by on-machine technology.



Storage

Telematics data flows into data storage. ISO 15143-3 (AEMP 2.0) facilitates the extraction and raw data to your choice of databases.



Connection

Choose how you want to connect and view your data. Go to multiple systems, send to a third party, or easily connect it all through My Komatsu.



Analytics

My Komatsu connects telematics data from Komatsu and non-Komatsu equipment and creates powerful analytics dashboard views.

Connect your machines to Smart Construction to optimize your job sites

Your projects depend on robust data that is easily shared, replicated, updated and — most important of all — correct.



Take a step toward a digital transformation of your job sites with Komatsu's suite of Smart Construction solutions, where advanced automation and integrated technologies intersect to help you:

- Track costs of labor, machines and materials
- Receive real-time insights straight from the field
- Enhance workflow with fully integrated data
- Visualize your data for actionable results
- Quickly map your job site
- Attract and retain talent



Not sure where to begin? Komatsu-certified solution experts are available on the phone, online or at your job site to help you navigate and thrive along your digitalization journey.

[komatsu.com/smart-construction](https://www.komatsu.com/smart-construction)

Komatsu maintenance and repair programs

Simplify the complexities of machine owning and operating costs and enhance the value of your equipment with Komatsu's tiered maintenance and repair offerings. Manage your active coverage programs through the My Komatsu customer interface and take advantage of attractive financing options.

- Solutions that fit your needs and ease your mind
- Fixed maintenance and repair costs for the life of the contract
- National coverage



Komatsu Care Complimentary

Complimentary maintenance

Our complimentary scheduled maintenance program for the first three years or 2,000 hours, whichever occurs first.

Komatsu Care Plus

Extended maintenance

A continuation of the Komatsu Care program. Along with regularly scheduled maintenance and national distributor coverage, you get a variety of added benefits.

Komatsu Care Plus II

Extended maintenance and repair

Everything in the Komatsu Care Plus program bundled with comprehensive repair coverage for qualifying repairs.

Komatsu Care Plus III

Extended maintenance, repair and consumables

A comprehensive program that simplifies your equipment's total cost of ownership with a fixed cost per hour for qualifying repairs and replacements.

Komatsu Care Advantage Warranty

Extended warranty

Protect your equipment in the event a covered component fails due to a defect in material or workmanship. Repairs are performed by Komatsu-trained experts using Komatsu genuine parts.

komatsu.com/maintenance-repair

Komatsu Financial

Financial services built for your business success.

komatsu.com/financing

Komatsu Genuine Parts

Engineered to help extend the life of your Komatsu machine. Now available on the My Komatsu parts store.

komatsu.com/parts

Komatsu training

Comprehensive training support — virtually, at our facility or where most convenient.

komatsu.com/training



General specification

Engine*

Model	Komatsu SAA4D95LE-7*		
Type	Water-cooled, 4-cycle, direct injection		
Aspiration	Variable flow, turbocharged, air-to-air aftercooled		
Number of cylinders	4		
Bore x stroke	95 mm x 115 mm 3.75" x 4.52"		
Piston displacement	3.26 L 199 in ³		
Horsepower			
SAE J1995	Gross	67 kW	91 HP
ISO 9249 / SAE J1349	Net	66 kW	89 HP
	Rated rpm	2,200	
Fan drive type	Hydraulic		
Governor	All-speed, electronic		
Lubrication system			
Method	Gear pump, forced lubrication		
Filter	Full-flow		

*EPA Tier 4 Final emissions certified.

Hydraulic transmission

Dual-path, hydrostatic transmission provides infinite speed changes up to 5.3 mph (8.5 km/h). The variable capacity travel motors allow the operator to select the optimum speed to match specific jobs. Travel control lock lever and neutral switch.

Travel speed (quick shift mode)*	Forward	Reverse
1st	0-3.4 km/h 0-2.1 mph	0-4.1 km/h 0-2.5 mph
2nd	0-5.6 km/h 0-3.5 mph	0-6.5 km/h 0-4.0 mph
3rd	0-8.5 km/h 0-5.3 mph	0-8.5 km/h 0-5.3 mph

Travel speed (variable mode)	Forward	Reverse
1st	0-8.5 km/h 0-5.3 mph	0-8.5 km/h 0-5.3 mph

*Quick shift speeds are adjustable in the monitor.

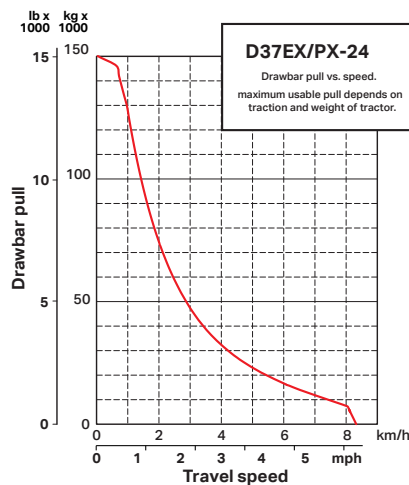

Final drives

In-shoe mounted axial piston-type travel motors with integrated two-stage planetary gear reduction. Compact in-shoe mount can reduce risk of damage by debris. Bolt-on sprocket ring with triple labyrinth seal design.

Steering system

Palm Command Control System (PCCS) joystick control for all directional movements. Pushing the joystick forward results in forward machine travel, while pulling it back reverses the machine. Simply tilt the joystick to the left or right to make a turn. Tilting the joystick fully to the left or right activates counter-rotation.

Hydrostatic transmission (HST) provides smooth, powerful turns. Fully electronic control enables smooth control that can be adjusted in the monitor. The PCCS utilizes shift buttons to increase and decrease speed.

Minimum turning radius*

D37EX-24	2.1 m 83"
D37PX-24	2.3 m 91"

*As measured by track marks on the ground at pivot turn.

Undercarriage

Suspension	Rigid type
Track roller frame	Monocoque, large section, durable construction
Rollers and idlers	Lubricated track rollers

Sealed and lubricated track Track tension easily adjusted with grease gun

Parallel Link Undercarriage System (PLUS) with lubricated rotating bushings for extended system wear life and lower maintenance costs. Track tension is adjusted easily with grease gun.

	D37EX-24	D37PX-24
Number of track rollers (each side)	6	6
Number of carrier rollers (each side)	1	1
Type of shoes (standard)	Single grouser	Single grouser
Number of shoes (each side)	41	41
Grouser height	47 mm 1.9"	47 mm 1.9"
Shoe width (standard)	460 mm 18"	600 mm 24"
Ground contact area	20,516 cm ² 3,180 in ²	26,760 cm ² 4,148 in ²
Ground pressure (with standard shoe) (ISO 16754)	38.3 kPa 0.39 kgf/cm ² 5.56 psi	29.9 kPa 0.30 kgf/cm ² 4.33 psi
Track gauge	1,570 mm 5'2"	1,710 mm 5'6"
Length of track on ground	2,230 mm 7'4"	2,230 mm 7'4"

Service refill capacities

Coolant	34 L	9.0 US gal
Fuel tank	190 L	50.2 US gal
Engine oil	11 L	2.9 US gal
Hydraulic tank	64 L	17 US gal
Final drive (each side)	3.5 L	0.9 US gal
DEF tank	10 L	2.6 US gal

Operating weight (approximate)

Tractor weight: Including ROPS cab, U frame for PAT dozer, rated capacity of lubricant, coolant, full fuel tank, operator and standard equipment.

D37EX-24	7,940 kg 17,505 lbs.
D37PX-24	8,170 kg 18,012 lbs.

Operator weight: Including PAT dozer, ROPS cab, operator, standard equipment, rated capacity of lubricant, hydraulic control unit, coolant and full fuel tank.

D37EX-24	9,000 kg 19,842 lbs.
D37PX-24	9,300 kg 20,503 lbs.

Dimensions

	D37EX-24		D37PX-24	
A	2,710 mm	8'11"	3,250 mm	10'8"
B	370 mm	1'3"	435 mm	1'4"
C	865 mm	2'10"	835 mm	2'7"
C'	1,075 mm	3'6"	1,075 mm	3'6"
D	800 mm	2'6"	800 mm	2'6"
E	380 mm	1'3"	380 mm	1'3"
F	2,230 mm	7'4"	2,230 mm	7'4"
G	4,275 mm	14'	4,275 mm	14'
H	2,785 mm	9'1"	2,785 mm	9'1"
I	47 mm	1.9"	47 mm	1.9"
J	1,570 mm	5'2"	1,710 mm	5'6"
K	460 mm	1'6"	600 mm	2'
L	1,970 mm	6'5"	2,310 mm	7'6"
M	2,510 mm	8'3"	2,960 mm	9'7"
N	4,780 mm	15'8"	4,880 mm	16'
O	2,480 mm	8'2"	2,905 mm	9'6"

Ground clearance: 325 mm 13"

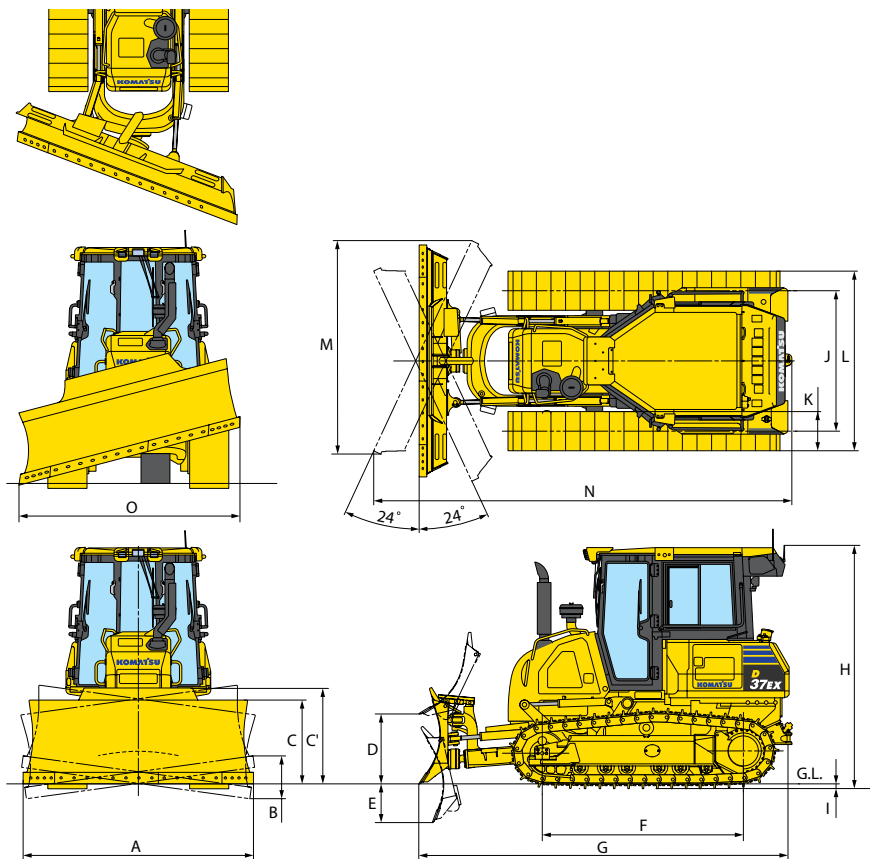

Hydraulic system

Closed-center load sensing system (CLSS) designed for precise and responsive control, and for efficient simultaneous operation.

Hydraulic control unit:

All spool control valves externally mounted remote to the hydraulic tank. Piston-type hydraulic pump with capacity (discharge flow) of 99 ltr/min 26.2 US gal/min at rated engine rpm.

Relief valve setting	27.4 MPa 280 kg/cm ² 3,974 psi	
Hydraulic cylinders	Double-acting, piston type	
	Number of cylinders	Bore
Blade lift	2	75 mm 3"
Blade tilt	1	90 mm 3.5"
Blade angle	2	80 mm 3.2"

Hydraulic oil capacity (refill)

Power angle tilt dozer	64 L 17 US gal
------------------------	----------------

Control valves

3-spool control valve for power angle tilt dozer

Positions

Blade lift	Raise, hold, lower and float
Blade tilt	Right, hold and left
Blade angle	Right, hold and left

Additional control valve required for ripper

Positions

Ripper lift	Raise, hold and lower
-------------	-----------------------

Dozer equipment

	Overall length with dozer*	Blade capacity	Blade width x height	Max. lift above ground	Max. drop below ground	Max. tilt adjustment	Blade angle
D37EX-24	4275 mm	1.91 m ³	2710 mm x 865 mm	800 mm	380 mm	370 mm	24°
Standard blade	14'	2.50 yd ³	8'11" x 2'10"	2'6"	1'3"	1'2"	
D37PX-24	4275 mm	2.13 m ³	3250 mm x 835 mm	800 mm	380 mm	435 mm	24°
Standard blade	14'	2.79 yd ³	10'5" x 2'9"	2'6"	1'3"	1'5"	
D37PX-24	4275 mm	1.95 m ³	2875 mm x 835 mm	800 mm	380 mm	390 mm	24°
Narrow blade	14'	2.55 yd ³	9'5" x 2'9"	2'6"	1'3"	1'3"	

Blade capacities are based on the recommended practice ISO 9246.

Use of high-tensile-strength steel in moldboard for strengthened blade construction.

*Including hitch

Equipment

Cab

Air conditioner: non-freon type, with heater, defroster and pressurizer	•
Automatic climate control	•
Cup holder	•
Electronic fuel control dial	•
Foot rests, high mounted	•
Front, rear and door wipers	•
Horn, electric	•
LED working lights, 3 front and 2 rear	•
Low-back air suspension seat, fabric material, with heat	•
Lunch box holder	•
Monitor: multi-function, 7 inch, high-resolution, color	•
Operator identification system	•
Radio, AM/FM with auxiliary jack	•
Rearview mirror	•
Rearview monitoring system (1 camera)	•
Retractable seat belt (3 in width)	•
ROPS cab (ISO 3471) and FOPS (ISO 3449) Level 2	•
Two 12V accessory outlets	•

Electrical system

Alternator (85 Amp, 24 Volt)	•
Back up alarm	•
Batteries, large capacity (2 x 12 Volt), (184 Ah)	•
Battery master disconnect switch with lockout tagout provision	•
Engine shutdown secondary switch	•
Engine Idle auto shutdown with adjustable timer	•
Starter motor (4.5kW/24V)	•

Engine

Above hood air intake pipe with centrifugal pre-cleaner	•
Air cleaner, double element with dust indicator	•
B20 compatible fuel lines	•
Fuel high efficiency filter	•
Fuel pre-filter with water separator	•
Grid heater - starting aid in cold weather	•
Komatsu SAA4D95LE-7, Tier 4 final, 3.26 L displacement	•
Komatsu Variable Geometry Turbocharger (KVGT)	•
KDOC - after-treatment assembly	•
Large-capacity cooling system	•
Programmable auto-idle shut down	•
Selective Catalytic Reduction (SCR)	•
Strainer, fuel tank fill	•
Swing-up radiator fan, reversible, electronic control, hydraulic driven, manual reversing	•

Hydraulics and controls

Accumulator for EPC	•
Electronic float function	•
Electronic Proportional Control (EPC) blade hydraulics	•
Hydraulics for front attachment	•
Rear hydraulics for scarifier or level 1 winch	○

Power train and steering controls

Combination brake / decel pedal	•
Counter rotation	•
Electronically controlled HST with Quickshift (3 speed) or variable (20 speed)	•
E/P/H working mode selection	•
Palm Command Control (PCCS) with electronic control	•
Reverse speed presets	•

Guards and covers

Battery lockout/tagout provision	•
Closed engine hood	•
Crankcase guard	•
Engine hood and side panel with locks	•
Final drive with triple labyrinth seal	•
Front pull hook	•
Hitch	○
Locks, filler caps and covers	•
Provision mounts for optional bolt-on screens	•
Sprocket inner guard	•
Track roller guards, end section	•
Track roller guards, full length	○
Under guard	•
Guarding - Komatsu (Ken Garner)	□
- Front sweeps	229 kg 584 lbs.
- Hinged cab side screens	44 kg 97 lbs.
- Hinged cab rear screen	43 kg 95 lbs.
- Rear A/C guard (requires front sweep)	61 kg 134 lbs.
- Poly panel door inserts	41 kg 91 lbs.

Technology

EMMS (Equipment Management Monitoring System) including system monitoring with self diagnostics	•
Komtrax, level 5 (4G)	•

Undercarriage and work equipment

Parallel Link Undercarriage System (PLUS)	•
400mm (16") single grouser track shoes (EX)	○
460mm (18") single grouser track shoes (EX)	•
600mm (24") single grouser track shoes (PX)	•
6 track / 1 carrier rollers (each side)	•
Self adjusting idler support with recoil spring	•
Sprockets, segmented	•
Multi-shank scarifier	○
-Weight	4700 kg 1,036 lb
-Beam length	1,569 mm 6'2"
-Maximum lift above ground	389 mm 1'3"
-Maximum digging depth	336 mm 1'1"
-Number of shanks	3
Hydraulic winch - Allied H4AT	685 kg 1,510 lb □

Other standard equipment

Grease gun holder	•
Marks and plates, for USA and Puerto Rico	•
Paint, Komatsu standard	•
Parts book and O&M Manual	•

*1 Dozer assembly and rear mounted equipment are not included in base machine standard equipment

For a complete list of available attachments, please contact your local Komatsu distributor

Standard equipment	•
Optional equipment	○
Optional (field install)	□

Product designs, specifications and/or data in this document are provided for informational purposes only and are not warranties of any kind. Product designs and/or specifications may be changed at any time without notice. The only warranties that apply to sales of products and services are Komatsu's standard written warranties, which will be furnished upon request.

Komatsu and other trademarks and service marks used herein are the property of Komatsu Ltd., Komatsu America Corp., Komatsu Mining Corp., or one of their affiliates, or the respective owners or licensees.

KOMATSU

komatsu.com

