

KOMATSU

D155AXi-8

Tier 4 Final Engine

CRAWLER DOZER

D155i



intelligent™
MACHINE CONTROL

Photos may include optional equipment.

NET HORSEPOWER

354 HP @ 1900 rpm
264 kW @ 1900 rpm

OPERATING WEIGHT

90,610 lb
41100 kg

BLADE CAPACITY

12.3 yd³ 9.4 m³ SIGMADOZER
12.3 yd³ 9.4 m³ Semi-U

WALK-AROUND

Next Generation Intelligence

No Cables

No coiled cables between machine and blade.

No Climbing

GNSS antenna and mast removed from blade.

No Connections

No daily connections required between machine and blade.

Innovative

Automated blade control from rough dozing to finish grade.

Integrated

Standard factory installed machine control system.

Intelligent

New dozing mode, load control performance features.



Photos may include optional equipment.

NET HORSEPOWER

354 HP @ 1900 rpm
264 kW @ 1900 rpm

OPERATING WEIGHT

90,610 lb
41100 kg

BLADE CAPACITY

12.3 yd³ 9.4 m³ SIGMADOZER
12.3 yd³ 9.4 m³ Semi-U

D155AXI-8

INNOVATIVE. INTEGRATED. INTELLIGENT.



Standard Intelligent Machine Control
Standard factory installed integrated 3D GNSS intelligent machine control system.

Improved Machine Control
Up to 8% more efficient dozer operation than comparable aftermarket machine control systems in start to finish grading tests.

Factory Installed Machine Control Components

Machine control components are factory installed and designed as an integral part of the base machine for improved durability.

Komatsu Quality

Machine control components and system validated to Komatsu's rigorous quality & durability standards.

Industry Standard Compatibility

Machine control system makes use of common industry design data file norms and supports typical base station communication.

Simple Operator Interface

Simple touch screen control box with multi-color customizable display.

3D GNSS Machine Control Standard

All on-machine components standard including control box, GNSS receiver/radio, GNSS antenna, and enhanced inertial measuring unit sensor.

Finish Grade Performance

Enhanced sensor package and intelligent logic provides for finish grade accuracy in an integrated system without traditional blade mounted sensors.

Enhanced Inertial Measuring Unit (IMU+)

Chassis mounted enhanced inertial measuring unit (IMU+) and intelligent logic provides for finish grade accuracy without blade mounted sensors.

Cab Top GNSS Antenna

Load control intelligence controls blade elevation to improve productivity and minimize track slip by adjusting blade load. 1.0' from grade or 0.1' from grade – you can run in auto mode.

Intelligent Dozing Mode Settings

Operators are able to select between 4 distinct machine control operating modes to optimize performance to the application whether cutting, spreading, or other.

Operator Selectable Load Settings

Machine control load settings can be adjusted between presets to tailor response to material conditions.

Komatsu SAA6D140E-7 variable geometry turbocharged and aftercooled 15.24 liter diesel engine

is EPA Tier 4 Final emissions certified.

- Heavy duty Selective Catalytic Reduction (SCR) system
- Diesel Exhaust Fluid (DEF) system
- Komatsu Diesel Particulate Filter (KDPF) system
- Heavy duty cooled Exhaust Gas Recirculation (EGR) system
- Electronic control system - seamless to the operator
- Variable Geometry Turbocharger (VGT) system
- Heavy duty High Pressure Common Rail (HPCR) fuel injection system

Fluid neutral or better

Fuel & DEF total consumption is less than fuel consumed by prior model.

Komatsu Diesel Particulate Filter (KDPF) and Selective Catalytic Reduction (SCR) systems reduce particulate matter and NOx while providing automatic regeneration that does not interfere with daily operation.

Variable Geometry Turbocharger (VGT) uses a hydraulic actuator to provide optimum air flow under all speed and load conditions.

Komatsu Auto Idle Shutdown helps reduce excessive idle time.

Rear hydraulics (standard)

Rear view monitoring system (standard)

Advanced diagnostic system continuously monitors machine operation and vital systems to identify machine issues, assists with troubleshooting, and minimizes down time.

The **KOMTRAX®** telematics system is standard on Komatsu equipment with no subscription fees throughout the life of the machine. Using wireless technology, **KOMTRAX®** transmits valuable information such as location, utilization, and maintenance records to a PC or smartphone app. Custom machine reports are provided for identifying machine efficiency and operating trends. **KOMTRAX®** also provides advanced machine troubleshooting capabilities by continuously monitoring machine health.

Parallel Link Undercarriage System (PLUS) (optional):

- Increases wear life up to two times
- Rotating bushings eliminate the cost and downtime for bushing turns
- Up to 40% lower undercarriage maintenance costs

** All comparisons are to the prior model, unless otherwise stated.

INTELLIGENT MACHINE CONTROL

Automatic Blade Control, Ranging from Heavy Dozing to Finish Grading

The D155AXi-8 features a 3D GNSS (Global Navigation Satellite System) machine control system which automatically controls the blade elevation and tilt per target design data. Not only can the automatic machine control features be used for finish grading but also for heavy (rough) dozing. Loading of the blade at the start

of the cut is controlled per set parameters. During the pass, if the load on the blade increases during heavy dozing operation, the blade is automatically raised to control the load and minimize shoe slip to ensure efficient dozing. When the blade approaches the target design surface, the blade will follow it for accurate finish grading.

1. Blade moves to target surface until load reaches a preset level.
2. The blade automatically raises to minimize track slip.
3. Should the load decrease, blade will lower to re-load blade to an optimum level.

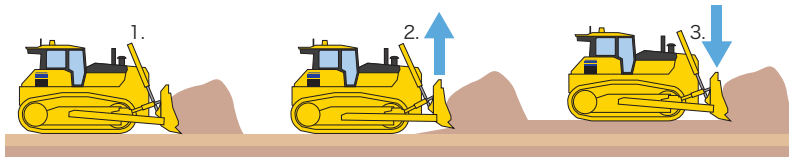

Operator Selectable Dozing Mode, Blade Load Settings

Dozing mode settings

Optimize machine performance for the given operation type.



Cutting and carry
Long, shallow cuts



Cutting
Front to back dozing



Spreading
Spreading a pile of material



Simple grading
Severe grade breaks, transitions

Blade load mode settings

Tailor blade loads to material conditions.



Light
Low traction application, low blade load due to material characteristics



Normal
Typical operation



Heavy
High traction application, high blade load due to material characteristics

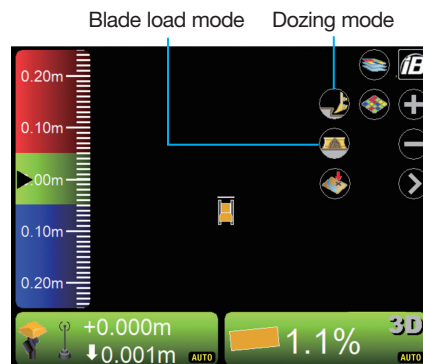

Auto/manual switch

Multiple passes, forward and reverse, can be made with automatics activated the entire time.



As-built Mapping Display for Checking Construction Progress

Cab top GNSS antenna provides for accurate as-built surface data collection by measuring actual elevations as machine continuously tracks in operation.

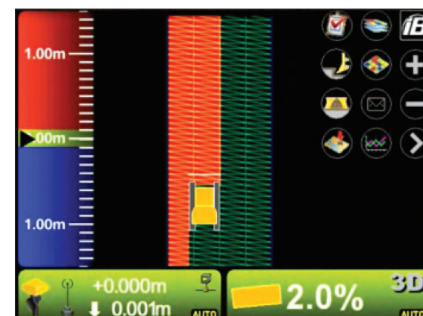



Advanced Sensor Technologies For Performance

GNSS antenna

Mounted to top of cab to minimize damage – not on the blade.

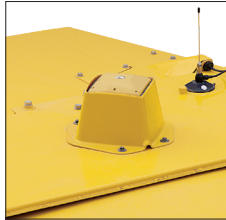

Enhanced inertial measuring unit (IMU+)

Chassis mounted IMU+ and intelligent logic enables accurate grading performance without blade mounted sensors.



Control box

Easy to use touchscreen display features bright graphics and customizable views. Mounting allows viewing angle to be adjusted per operator preference.

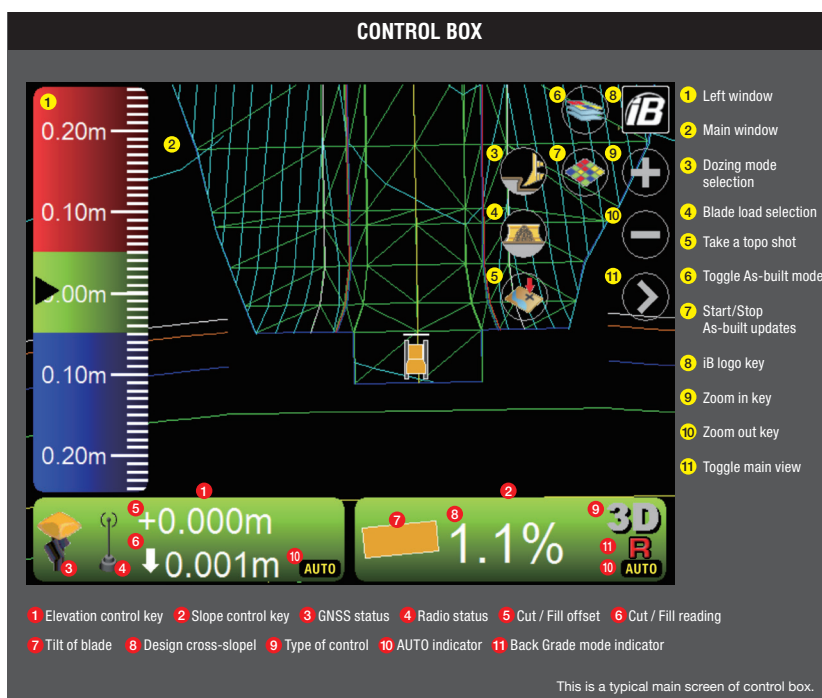

Stroke sensing hydraulic cylinders

Robust stroke sensing hydraulic cylinders employ proven Komatsu sensor technologies for accurate finish grade performance.



Factory Installed Machine Control System For Quality, Durability

Machine control system components are factory installed and designed as an integral part of the machine.

PERFORMANCE FEATURES

KOMATSU NEW ENGINE TECHNOLOGIES

New Tier 4 Final Engine

The Komatsu SAA6D140E-7 engine is EPA Tier 4 Final emissions certified and provides exceptional performance while reducing fuel consumption. Based on Komatsu proprietary technologies developed over many years, this new diesel engine reduces nitrogen oxides (NOx) by more than 80% when compared to Tier 4 interim levels. Through the in-house development and production of engines, electronics, and hydraulic components, Komatsu has achieved great advancements in technology, providing high levels of performance and efficiency in virtually all applications.

Technologies Applied to New Engine

Heavy-duty aftertreatment system

This new system combines a Komatsu Diesel Particulate Filter (KDPF) and Selective Catalytic Reduction (SCR). The SCR NOx reduction system injects the correct amount of DEF at the proper rate, thereby decomposing NOx into non-toxic water (H₂O) and nitrogen gas (N₂).

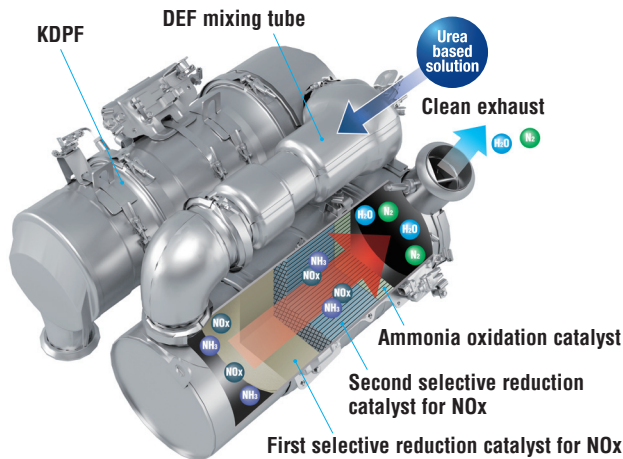

Heavy-duty cooled Exhaust Gas Recirculation (EGR) system

The system recirculates a portion of exhaust gas into the air intake and lowers combustion temperatures, thereby reducing NOx emissions. EGR gas flow has been decreased for Tier 4 Final with the addition of SCR technology. The system achieves a dynamic reduction of NOx, while helping reduce fuel consumption below Tier 4 Interim levels.

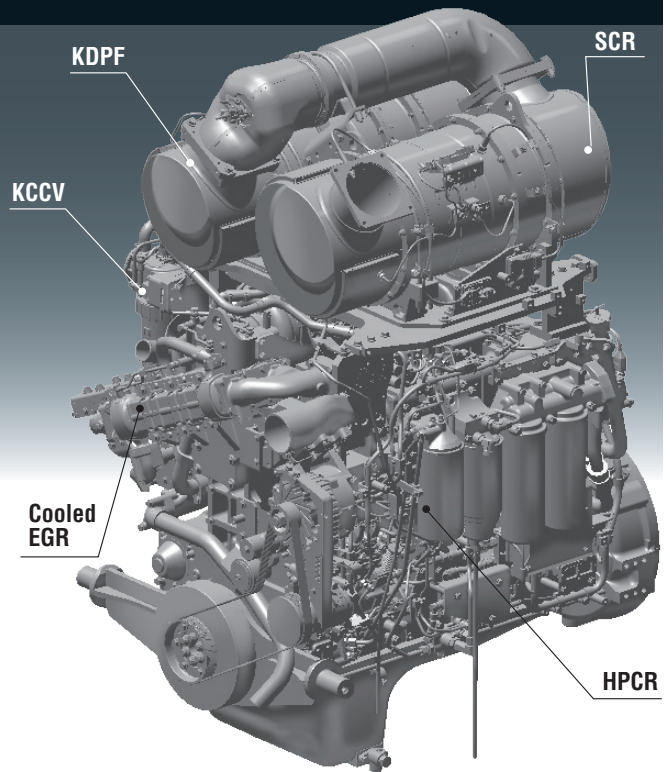
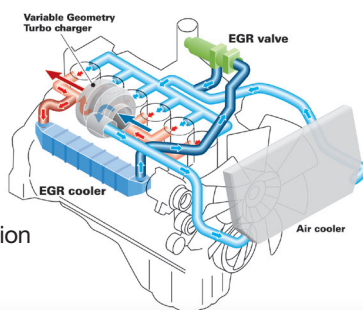

Advanced Electronic Control System

The electronic control system performs high-speed processing of all signals from sensors installed in the vehicle providing total control of equipment in all conditions of use. Engine condition information is displayed via an on-board network to the monitor inside the cab, providing necessary information to the operator. Additionally, managing the information via KOMTRAX helps customers keep up with required maintenance.

Variable Geometry Turbocharger (VGT) system

The VGT system features proven Komatsu design hydraulic technology for variable control of air-flow and supplies optimal air according to load conditions. The upgraded version provides better exhaust temperature management.

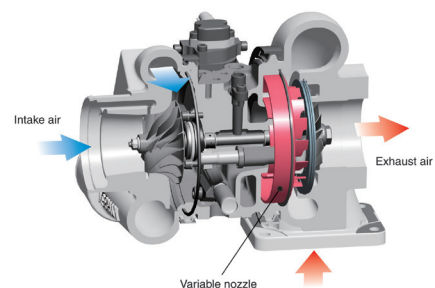

Komatsu Auto Idle Shutdown

Komatsu auto idle shutdown automatically shuts the engine down after idling for a set period of time to reduce unnecessary fuel consumption and exhaust emissions. The amount of time before the engine is shutdown can be easily programmed from 5 to 60 minutes.

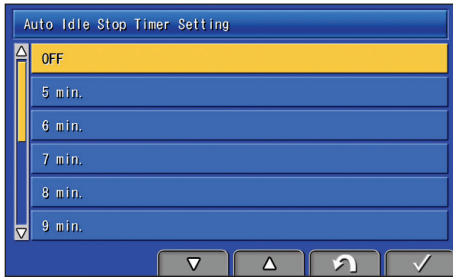

Secondary Engine Shutdown Switch

A secondary switch is at the side of the front console to shut down the engine.



Heavy-Duty High-Pressure Common Rail (HPCR) Fuel Injection System

The system is designed to achieve an optimal injection of high-pressure fuel by means of computerized control, providing close to complete combustion to reduce PM emissions. While this technology is already used in current engines, the new system uses high pressure injection, thereby reducing both PM emissions and fuel consumption over the entire range of engine operating conditions. The Tier 4 Final engine has advanced fuel injection timing for reduced fuel consumption and lower soot levels.

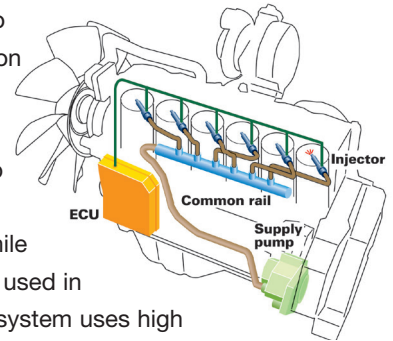

Hydraulically Driven Cooling Fan

The engine cooling fan rotation speed is electronically controlled. The fan rotation speed depends on engine coolant, powertrain oil and hydraulic oil temperatures. The higher the temperature the higher the fan speed. This system increases fuel efficiency, reduces the operating noise levels and requires less horsepower than a belt driven fan. The fan is manually reversible by the operator for periodic cleaning.



PERFORMANCE FEATURES

D155AXi-8

- 1 Automatic transmission with lockup torque converter
- 2 KOMATSU SAA6D140E-7 engine
- 3 SIGMADOZER

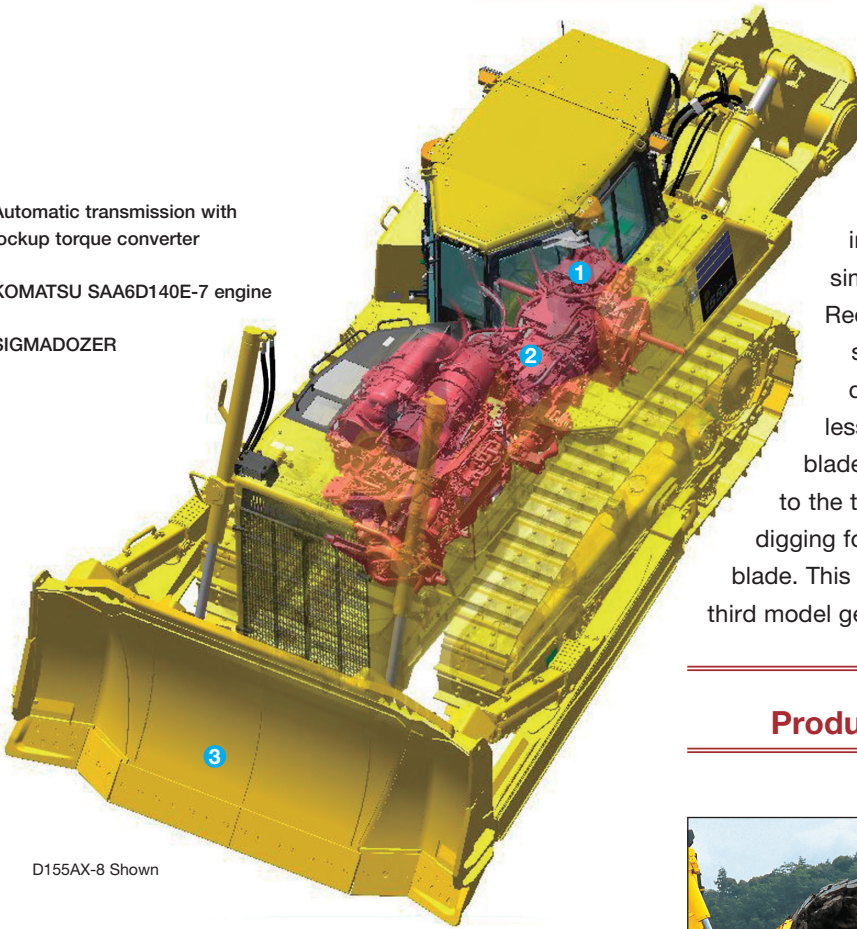

D155AX-8 Shown

New Fuel Efficient Bulldozer

New D155AXi-8 has achieved both high levels of productivity and fuel economy through usage of SIGMADOZER and automatic transmission with lockup torque converter.

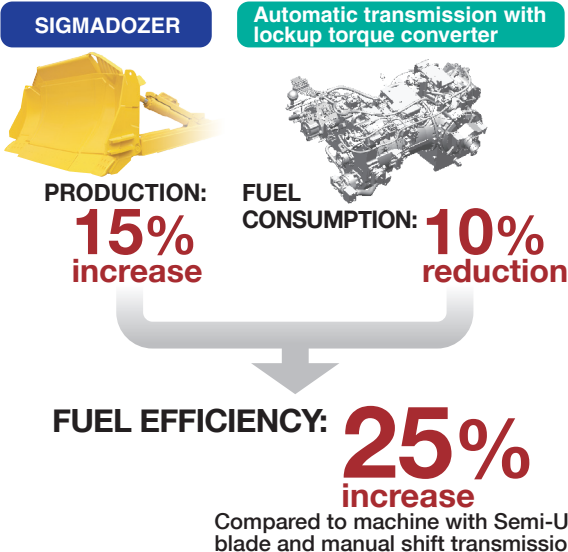

Innovative SIGMADOZER

Based on a completely new digging theory, SIGMADOZER dramatically improves dozing performance and increases productivity. A new frontal design concept adopted for digging and rolling up at the center of the blade increases soil holding capacity, simultaneously reducing sideway spillage. Reduced digging resistance produces smoother flow of earth, enabling the dozing of larger quantities of soil with less power. In addition, adoption of a new blade linkage system holds the blade closer to the tractor for improved visibility, enhanced digging force and reduced lateral sway of the blade. This is the new generation blade now in its third model generation.

Production increased by 15%

Compared to conventional Semi-U blade



SIGMADOZER



Semi-U blade

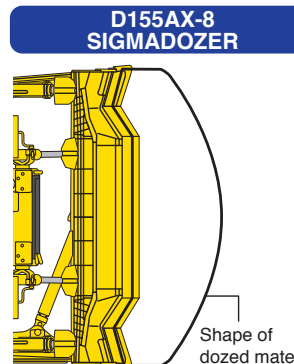

Shape of dozed material

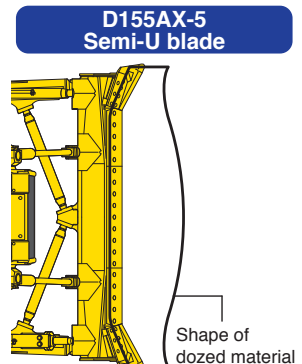

Shape of dozed material

Automatic Transmission with Lockup Torque Converter

A sharp reduction in fuel consumption and greater power train efficiency is achieved by the automatic gearshift transmission and lock up torque converter. The automatic gearshift transmission selects the optimal gear range depending on the working conditions and load placed on the machine. This means the machine is designed to operate at maximum efficiency. (Manual gearshift mode is selectable with a switch).

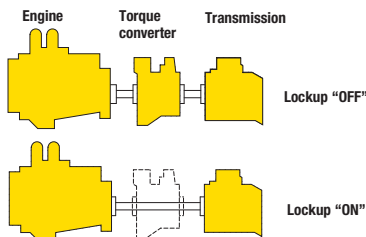

Fuel consumption reduced by 10%

Compared to machine with manual shift transmission

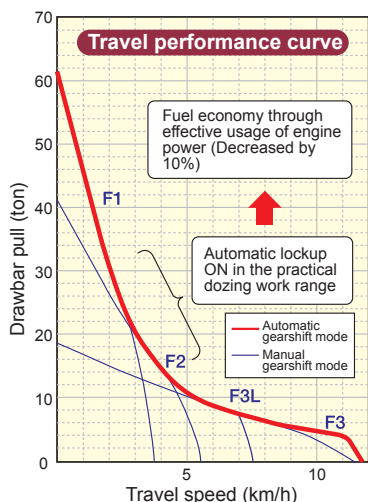

Lockup mechanism of torque converter is automatically actuated to transfer engine power directly to the transmission in usual dozing speed range. Locking up the torque converter eliminates loss of horsepower by 10%. Because the electronically controlled engine is extremely efficient, a decrease in fuel consumption is realized while also maintaining machine power.

Automatic/Manual Gearshift Selectable Mode

Automatic or manual gearshift modes can be selected with ease to suit the work at hand by simply pressing the switch on the multi-monitor (selection in neutral).

Automatic gearshift mode

The mode for general dozing. When a load is applied, the gear automatically shifts down, and when the load is off, it automatically shifts up to a set maximum gear speed. This mode economizes both fuel and production where the torque converter lockup mechanism is actuated according to load, automatically selecting the optimum gear speed.

Manual gearshift mode

The mode for dozing and ripping rough ground. When enabled, the gear automatically shifts down, but does not shift up when the load is off. The operator can specify whether the auto shift down function is enabled or disabled by selection in the monitor.

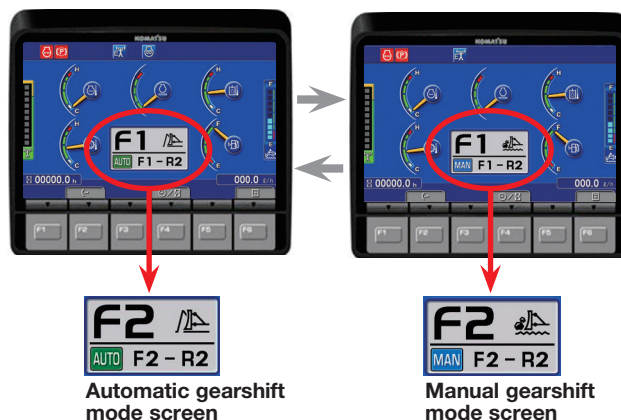

CONTROL FEATURES

Palm Command Electronic Controlled Travel Control Joystick

Palm command travel joystick provides the operator with a relaxed posture and superb fine control without operator fatigue. Transmission gear shifting is simplified with thumb push buttons.

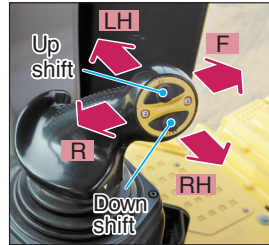

Gearshift Pattern Preset Function

When the gearshift pattern is set to either <F1-R2>, <F2-R2> or <F2-R3L> in automatic gearshift mode, the gear is automatically shifted, reducing round trip repetition work time and operator's effort.



Automatic gearshift mode

F1-R1 MODE
Press DOWN switch ↑ Press UP switch ↓

F1-R2 MODE
Press DOWN switch ↑ Press UP switch ↓

F2-R2 MODE
Press DOWN switch ↑ Press UP switch ↓

F2-R3L MODE

Manual gearshift mode

F1-R1 MODE
Press DOWN switch ↑ Press UP switch ↓

F1-R2 MODE
Press DOWN switch ↑ Press UP switch ↓

F2-R2 MODE

Palm Command Electronic Controlled Blade/Ripper Control Joystick

Electronically-controlled palm command joystick is equipped for blade/ripper control. Combined with the highly reliable Komatsu hydraulic system, superb control is the result.

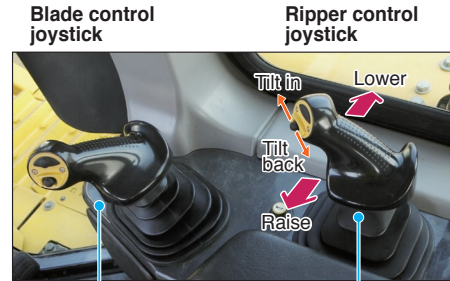

Blade control joystick

Ripper control joystick

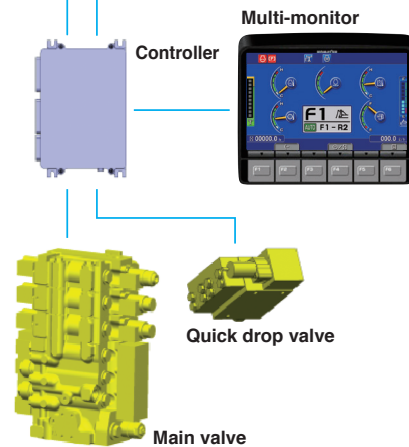

Electronic Controlled Modulation Valve (ECMV) Controlled Transmission and Brakes

Controller automatically adjusts each clutch engagement depending on travel conditions, providing smooth shockless clutch engagement, improved component life and operator ride comfort.

Hydrostatic Steering System (HSS) – Smooth, Powerful Turning

The engine power is transmitted to both tracks without power interruption on the inside track for smooth, powerful turns. Counter-rotation while in neutral is available for minimum turning radius providing excellent maneuverability.



D155AX-8 Shown

Ripper Auto-return

The ripper control lever is new, ergonomic and incorporates an auto-return function that will automatically raise the ripper so the operator is less fatigued at the end of the day. The function starts when travel lever is moved to reverse position.

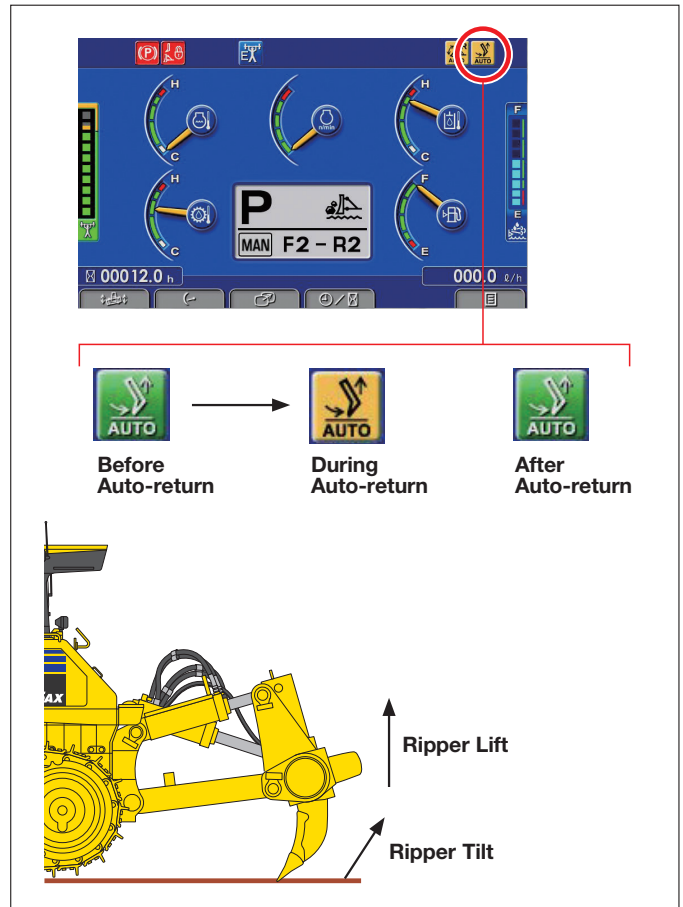
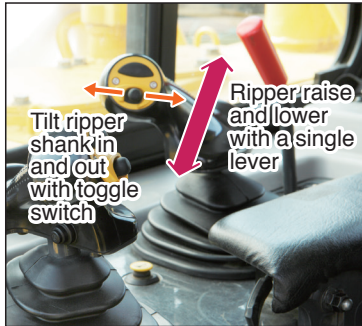

WORKING ENVIRONMENT

D155AXi-8



Integrated ROPS Cab

The D155AXi-8 has a tall and long integrated ROPS cab with large glass windows for outstanding visibility. High rigidity and superb sealing performance greatly reduce noise and vibration for the operator and helps prevent dust from entering the cab. The standard air-suspension seat positions the operator comfortably. Cab meets OSHA/MSHA/ROPS and FOPS Level 2 standards.



Rear View Monitoring System (standard)

The operator can view the rear of the machine with a color monitor screen.

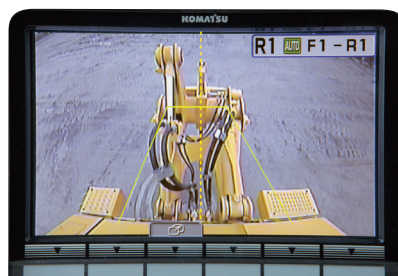

Comfortable Ride with Cab Damper Mounting

The D155AXi-8's cab mount uses a cab damper which provides excellent shock and vibration absorption capacity with its long stroke. Cab damper mounts soften shocks and vibration while traveling over adverse conditions, which conventional mounting systems are unable to match. The cab damper spring isolates the cab from the machine body, suppressing vibration and providing a quiet, comfortable operating environment.

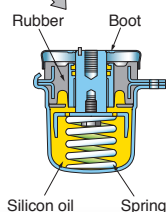

Ripper Visibility

Ripper cylinders were reduced from four to two, greatly improving rear visibility during ripping. Also, expanded ripper movement offers a wider range of operation.

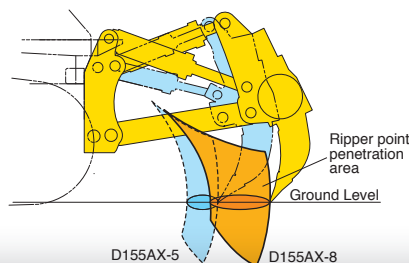

MAINTENANCE FEATURES

DEF Tank

A large tank volume extends operating time before refilling and is installed at the operator cab left platform for ease of access.



Parallel Link Undercarriage System (PLUS) (Optional)

Undercarriage wear life is increased by up to two times and the cost of a bushing turn and downtime is eliminated. Undercarriage maintenance costs are lowered by up to 40%.

Rotating bushing

Closed construction

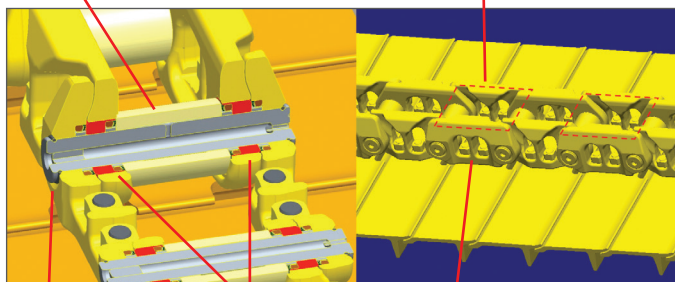

Wedge ring

Seal for rotating bushing

Parallel link

Flat Face O-ring Seals

Flat face O-ring seals are used to securely seal all hydraulic hose connections and to help prevent oil leakage.

Wide Core Cooling System

In addition to improved engine compartment sealing, a wide core cooling system is standard. Radiator, oil cooler and charge air cooler use large square-wave fins spaced at 6 fins per inch. This allows more material to pass through, which helps self-cleaning and reduces maintenance.

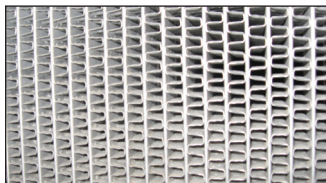

Battery Disconnect Switch

A standard battery disconnect switch allows a technician to disconnect the power supply before servicing the machine.



Maintenance Records

Machine monitor stores and displays maintenance records including scheduled service interval and remaining service hours.

Maintenance	Interval	Remain
Fuel Pre-filter Change	500 h	495 h
Engine Oil Change	500 h	495 h
Engine Oil Filter Change	500 h	495 h
P/T Oil Filter Change	500 h	495 h
Fuel Main Filter Change	1000 h	995 h

Easy Radiator Cleaning

The radiator can be cleaned by utilization of the reversible, hydraulically driven cooling fan. The fan can be reversed from inside the cab by simply activating via the monitor to reverse. Hinged double doors open wide for access to radiator.



Oil Pressure Checking Ports

Pressure checking ports for power train components are centralized to promote quick and simple diagnosis.

Concentrated Engine Check Points

The opening area is large when the gull-wing engine side covers are opened, facilitating engine daily checks and maintenance. Side covers have been changed to a thick one-piece structure with a bolt-on latch to improve durability.



KOMATSU PARTS & SERVICE SUPPORT



KOMATSU CARE®

Program Includes:

*The D155AXi-8 comes standard with complimentary factory scheduled maintenance for the first 3 years or 2,000 hours, whichever comes first.

Planned Maintenance Intervals at:

500/1000/1500/2000 hour intervals. (250 hr. initial interval for some products) Complimentary Maintenance Interval includes: Replacement of Oils & Fluid Filters with genuine Komatsu Parts, 50-Point inspection, Komatsu Oil & Wear Analysis Sampling (KOWA) / Travel & Mileage (distance set by distributor; additional charges may apply).

Benefits of Using Komatsu CARE

- Assurance of Proper Maintenance with OEM Parts & Service
- Increased Uptime & Efficiency
- Factory Certified Technicians Performing Work
- Cost of Ownership Savings
- Transferable Upon Resale

Komatsu CARE® – Advantage Extended Coverage

- Extended Coverage can provide peace of mind by protecting customers from unplanned expenses that effect cash flow
- Purchasing extended coverage locks-in the cost of covered parts and labor for the coverage period and helps turn these into fixed costs



Komatsu Oil and Wear Analysis (KOWA)

- KOWA detects fuel dilution, coolant leaks, and measures wear metals
- Proactively maintain your equipment
- Maximize availability and performance
- Can identify potential problems before they lead to major repairs
- Reduce life cycle cost by extending component life

Interval PM	i250	500	1000	1500	2000
PERFORM KOWA SAMPLING- engine sample only	✓				
CHANGE HYDRAULIC OIL	✓				✓
REPLACE HYDRAULIC OIL FILTER	✓				✓
CHANGE FINAL DRIVE OIL	✓		✓		✓
CHANGE POWER TRAIN OIL	✓		✓		✓
CLEAN POWER TRAIN PUMP STRAINER	✓		✓		✓
CLEAN SCAVENGING PUMP STRAINER	✓		✓		✓
REPLACE POWER TRAIN OIL FILTER	✓	✓	✓	✓	✓
LUBRICATE MACHINE	✓	✓	✓	✓	✓
CLEAN AIR CLEANER ELEMENT	✓	✓	✓	✓	✓
DRAIN SEDIMENT FROM FUEL TANK	✓	✓	✓	✓	✓
COMPLETE 50 POINT INSPECTION FORM; LEAVE PINK COPY WITH CUSTOMER OR IN CAB	✓	✓	✓	✓	✓
RESET MONITOR PANEL MAINTENANCE COUNTER FOR APPROPRIATE ITEMS	✓	✓	✓	✓	✓
PERFORM KOWA SAMPLING- engine, l&r final drive, transmission, hydraulics		✓	✓	✓	✓
REPLACE FUEL PRE-FILTER		✓	✓	✓	✓
CHANGE ENGINE OIL		✓	✓	✓	✓
REPLACE ENGINE OIL FILTER CARTRIDGE		✓	✓	✓	✓
REPLACE A/C FRESH AND RECIRC AIR FILTERS		✓	✓	✓	✓
LUBRICATE UNIVERSAL JOINT			✓		✓
REPLACE FUEL MAIN FILTER			✓		✓
REPLACE FUEL TANK BREATHER ELEMENT			✓		✓
REPLACE POWER TRAIN CASE BREATHER ELEMENT			✓		✓
REPLACE DEF TANK BREATHER			✓		✓
REPLACE HYDRAULIC TANK BREATHER ELEMENT			✓		✓
REPLACE PILOT FILTER ELEMENT			✓		✓
CLEAN FUEL STRAINER			✓		✓
CHANGE DAMPER CASE OIL					✓
CLEAN DAMPER BREATHER					✓
CHECK PIVOT BEARING OIL (ADD WHEN NECESSARY)					✓
REPLACE DEF FILTER					✓
REPLACE KCCV FILTER ELEMENT					✓
FACTORY TRAINED TECHNICIAN LABOR	✓	✓	✓	✓	✓

Komatsu Parts Support

- 24/7/365 to fulfill your parts needs
- 9 parts Distribution Centers strategically located across the U.S. and Canada
- Distributor network of more than 300 locations across U.S. and Canada to serve you
- Online part ordering through Komatsu eParts
- Remanufactured components with same-as-new warranties at a significant cost reduction



* Certain exclusions and limitations apply. Refer to the customer certificate for complete program details and eligibility. Komatsu® and Komatsu Care® are registered trademarks of Komatsu Ltd. Copyright 2018 Komatsu America Corp.

D155AXi-8

KOMTRAX EQUIPMENT MONITORING

GET THE WHOLE STORY WITH
KOMTRAX[®]

✓ **WHAT**

- KOMTRAX is Komatsu's remote equipment monitoring and management system
- KOMTRAX **continuously monitors and records** machine health and operational data
- Information such as fuel consumption, utilization, and a detailed history **lowering owning and operating cost**

✓ **WHEN**

- Know when your machines are **running or idling** and make decisions that will improve your fleet utilization
- Detailed movement records ensure you know when and where your equipment is moved
- Up to date records allow you to **know when maintenance is due** and help you plan for future maintenance needs

✓ **WHERE**

- KOMTRAX data **can be accessed virtually anywhere** through your computer, the web or your smart phone
- Automatic alerts keep fleet managers up to date on the latest machine notifications

✓ **WHY**

- Knowledge is power - **make informed decisions** to manage your fleet better
- Knowing your idle time and fuel consumption will help maximize your machine efficiency
- **Take control of your equipment** - any time, anywhere

✓ **WHO**

- KOMTRAX is **standard** equipment on all Komatsu construction products



KOMTRAX[®]

For construction and compact equipment.

KOMTRAX Plus[®]

For production and mining class machines.

SPECIFICATIONS



ENGINE

Model.....Komatsu SAA6D140E-7**
 Type.....4-cycle, water-cooled, direct injection
 Aspiration.....Variable Geometry Turbocharged,
 air-to-air aftercooled, cooled EGR
 Number of cylinders.....6
 Bore x stroke.....140 mm x 165 mm **5.51" x 6.50"**
 Piston displacement 15.24 ltr **930 in³**
 Governor.....Mid-range, electronic
 Horsepower
 SAE J1995.....Gross 268 kW **360 HP**
 ISO 9249 / SAE J1349*.....Net 264 kW **354 HP**
 Rated rpm 1900 rpm
 Fan drive typeHydraulic
 Lubrication system
 Method.....Gear pump, force lubrication
 Filter.....Full-flow

*Net horsepower at the maximum speed of radiator cooling fan 239 kW **320 HP**

**EPA Tier 4 Final emissions certified



TORQFLOW TRANSMISSION

Komatsu's automatic TORQFLOW transmission consists of a water-cooled, 3-element, 1-stage, 1-phase, torque converter with lockup clutch, and a planetary gear, multiple-disc clutch transmission which is hydraulically actuated and force-lubricated for optimum heat dissipation. Equipped with gearshift lock lever and neutral safety switch.

Travel speed	Forward	Reverse
1st	3.8 km/h 2.4 mph	4.6 km/h 2.9 mph
2nd	5.6 km/h 3.5 mph	6.8 km/h 4.2 mph
3rd L	7.5 km/h 4.7 mph	9.2 km/h 5.7 mph
3rd	11.6 km/h 7.2 mph	14.0 km/h 8.7 mph

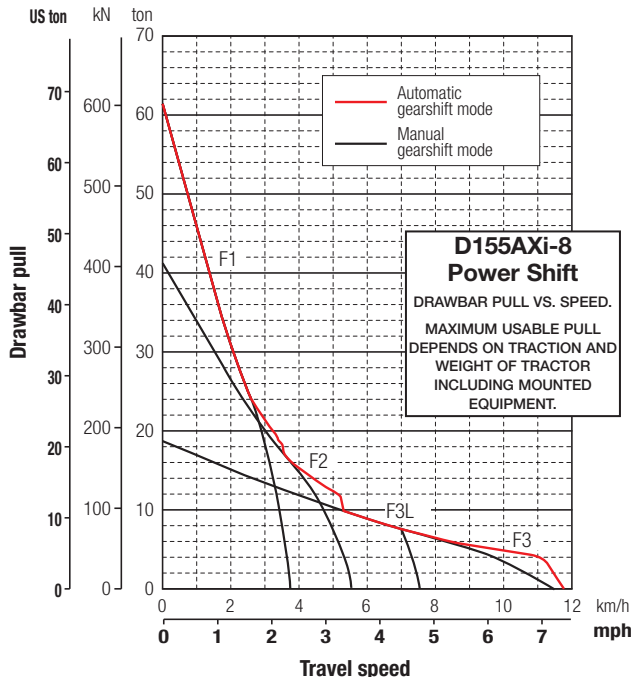

FINAL DRIVES

Double-reduction, spur and planetary final drives increase tractive effort. Segmented sprockets are bolt-on for easy in-the-field replacement.



STEERING SYSTEM

PCCS lever controls for all directional movements. Pushing the PCCS lever forward results in forward machine travel, while pulling it rearward reverses the machine. Simply tilt the PCCS lever to the left to make a left turn. Tilt it to the right for a right turn.

Hydrostatic steering system (HSS) is powered by steering planetary units and an independent hydraulic pump and motor. Counter-rotation turns are also available. Wet, multiple-disc, pedal-controlled service brakes are spring-actuated and hydraulically released. Gearshift lock lever also applies parking brakes.

Minimum turning radius 2.14 m **7'0"**



UNDERCARRIAGE

Suspension Oscillation-type with equalizer bar and forward mounted pivot shafts
 Track roller frame Monocoque, high-tensile-strength steel construction

K-Bogie undercarriage

Lubricated track rollers are resiliently mounted the track frame with a bogie suspension system whose oscillating motion is cushioned by rubber pads.

Track shoes

Lubricated tracks. Unique dust seals for preventing entry of foreign abrasives into pin-to-bushing clearance for extended service. Track tension easily adjusted with grease gun.

Number of shoes (each side) 42
 Grouser height 80 mm **3.1"**
 Shoe width (standard/maximum) 610 mm **24"/710 mm 28"**
 Ground contact area 39955 cm² **6,193 in²**
 Number of track rollers (each side) 7
 Number of carrier rollers (each side) 2



SERVICE REFILL CAPACITIES

Fuel tank 625 ltr **165 U.S. gal**
 Coolant 104 ltr **27.5 U.S. gal**
 Engine oil 37 ltr **9.8 U.S. gal**
 Damper 1.5 ltr **0.4 U.S. gal**
 Transmission, bevel gear, steering system 90 ltr **23.8 U.S. gal**
 Final drive (each side) 31 ltr **8.2 U.S. gal**
 DEF tank 39 ltr **10.3 U.S. gal**
 Hydraulic oil capacity 95 ltr **25.1 U.S. gal**



OPERATING WEIGHT (APPROXIMATE)

Tractor weight 32760 kg **72,223 lb**
 Including rated capacity of lubricant, coolant, full fuel tank, operator, and standard equipment (including ROPS cab).

Operating weight 41100 kg **90,610 lb**
 Including strengthened SIGMADOZER, giant ripper, ROPS cab, operator, standard equipment, rated capacity of lubricant, coolant, and full fuel tank.

Ground pressure 100.9 kPa 1.03 kg/cm² **14.6 psi**



DIMENSIONS

A	4060 mm	13'4"
B	2140 mm	7'0"
C	3385 mm	11'1"
D	1850 mm	6'1"
E	3275 mm	10'9"
F	8420 mm	27'7"
G	2745 mm	9'0"
H	1240 mm	4'1"
I	950 mm	3'1"
J	3570 mm	11'9"

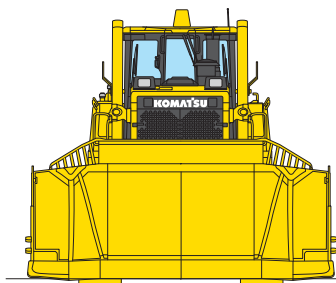
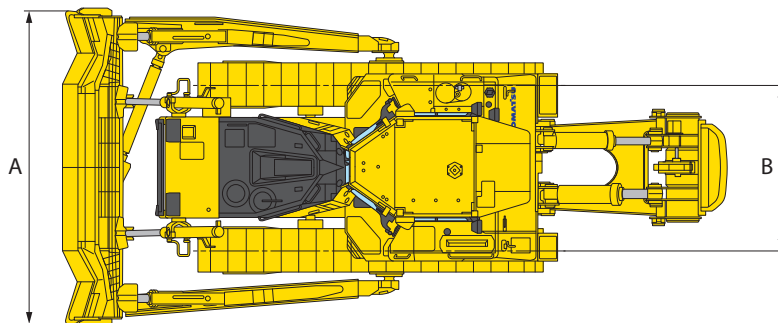

Ground clearance: 500 mm **1'8"**

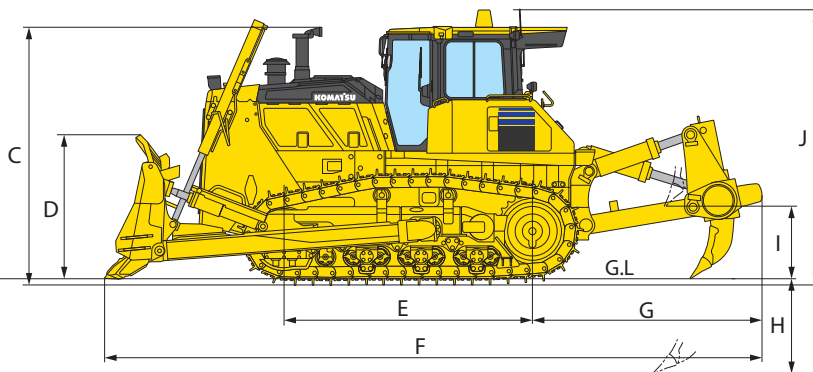

HYDRAULIC SYSTEM

Closed-center load sensing system (CLSS) designed for precise and responsive control, and for efficient simultaneous operation.

Hydraulic control unit:

All spool control valves externally mounted beside the hydraulic tank.

Variable piston pump with capacity (discharge flow) of 325 L/min **85.9 U.S. gal** for steering and 180 L/min **47.6 U.S. gal** for implement at rated engine rpm.

Relief valve setting

- ... for implement 27.5 MPa 280 kg/cm² **3,980 psi**
- ... for steering 38.2 MPa 390 kg/cm² **5,550 psi**

Control valves:

Spool control valve for SIGMADOZER and Semi-U tilt dozer.

- Positions: Blade lift Raise, hold, lower, and float
- Blade tilt Right, hold, and left

Additional control valve required for variable digging angle multi-shank ripper and giant ripper.

- Positions: Ripper lift Raise, hold, and lower
- Ripper tilt Increase, hold, and decrease
- Hydraulic cylinders Double-acting, piston

	Number of cylinders	Bore
Blade Lift	2	110 mm 4.33"
Blade Tilt	1	160 mm 6.30"
Ripper Lift	1	180 mm 7.09"
Ripper Tilt	1	200 mm 7.87"

Hydraulic oil capacity (refill):

- SIGMADOZER 95.0 ltr **25.1 U.S. gal**
- Semi-U tilt dozer 95.0 ltr **25.1 U.S. gal**

Ripper equipment (additional volume):

- Multi-shank ripper 37 ltr **9.8 U.S. gal**
- Giant ripper 37 ltr **9.8 U.S. gal**



DOZER EQUIPMENT

Use of high-tensile-strength steel in moldboard for strengthened blade construction. Blade tilt hose piping is mounted inside the dozer push arm to protect from damage.

	Overall Length With Dozer	Blade Capacity	Blade Length x Height	Max. Lift Above Ground	Max. Drop Below Ground	Max. Tilt Adjustment	Additional Weight
Strengthened SIGMADOZER*	6320 mm 20'9"	9.4 m ³ 12.3 yd³	4060 mm x 1850 mm 13'4" x 6'1"	1315 mm 4'4"	676 mm 2'3"	870 mm 2'10"	5900 kg 13,007 lb
Semi-U Tilt Dozer*	6370 mm 20'11"	9.4 m ³ 12.3 yd³	4130 mm x 1790 mm 13'7" x 5'10"	1245 mm 4'1"	590 mm 1'11"	860 mm 2'10"	5900 kg 13,007 lb

* Dual Tilt Dozer

Notes

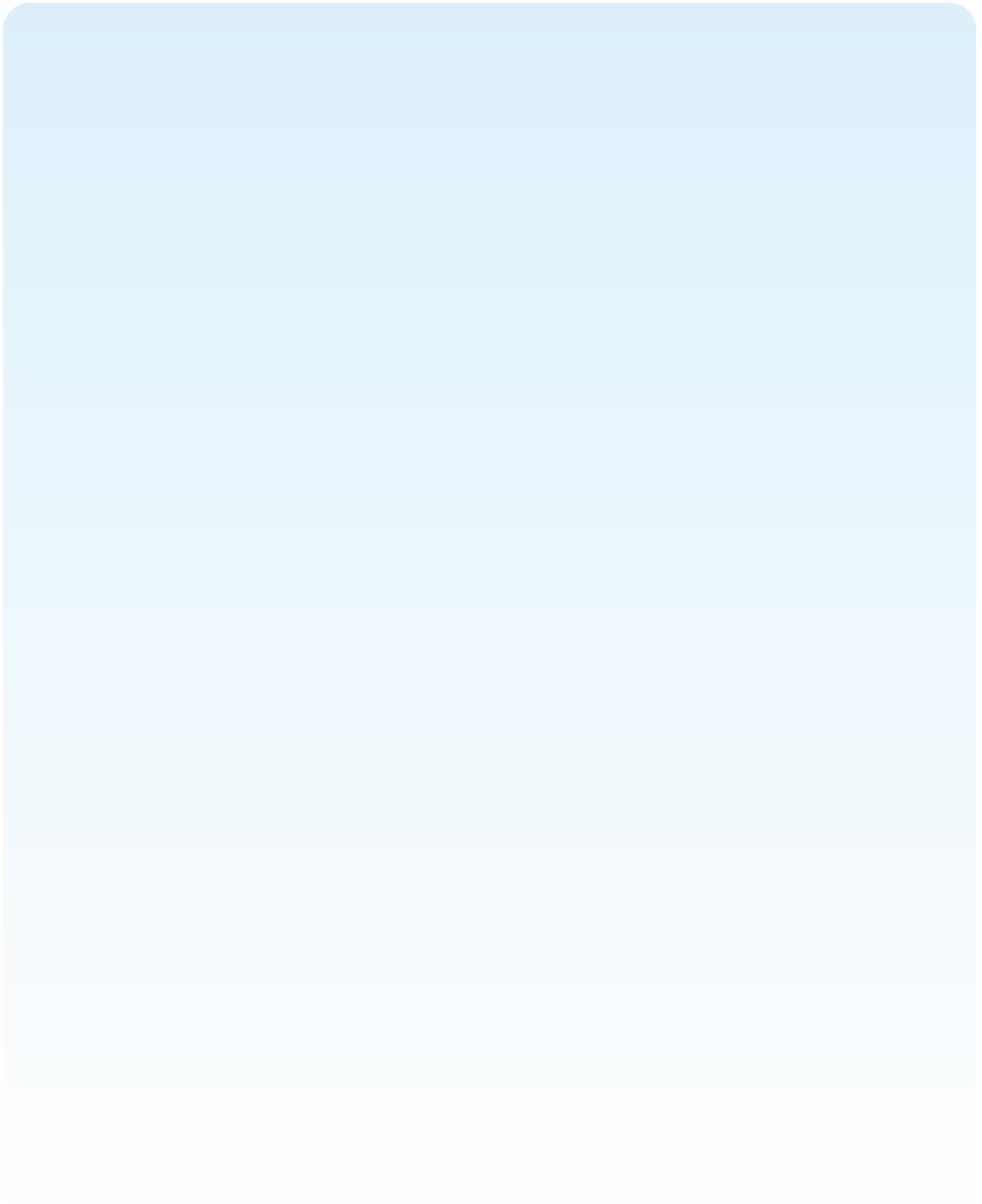





STANDARD EQUIPMENT FOR BASE MACHINE*

- Air cleaner, double element with dust indicator
- Alternator, 140 ampere/24V
- Backup alarm
- Batteries, 200 Ah/2 x 12V
- Battery disconnect switch
- Blade lift cylinders with double dust seal
- Color monitor, LCD
- Decelerator pedal
- Engine hood
- Engine idle auto shutdown with adjustable timer
- Engine intake centrifugal precleaner
- Engine, gull-wing side covers
- Engine shutdown secondary switch
- Exhaust pipe with raincap
- Fast fuel provision
- Fenders
- Front pull hook
- Fuel pre-filter and primary filter
- Grid heater starting aid in cold weather
- High mount foot rests
- Horn, warning
- Hydraulic driven radiator cooling fan with manual reverse clean mode
- Hydraulics to match dozer push-group configuration
- Hydraulics for ripper VGR/MSR
- KOMTRAX® Level 5
- K-bogie undercarriage
- Komatsu Diesel Particulate Filter (KDPF)
- Komatsu Selective Catalytic Reduction (SCR)
- Locks, filler caps and covers
- Oil pressure check ports for power train
- PM service connector
- Radiator mask, double door, heavy-duty, hinged, perforated
- Radiator reserve tank
- Rear cover
- ROPS cab (1420 kg, **3,131 lb**)**
 - Air conditioner/heater/defroster
 - Pressurized
 - Condenser remote mounted
 - Cab accessories
 - 12V power supply (2 ports)
 - Cup holder
 - Rearview mirror
 - Rear view monitoring (1 camera)
 - AM/FM Radio w/remote AUX plug (3.5 mm)
 - Lunch box holder
 - Work lights
 - 2 front, hood mounted
 - 2 front, cab mounted
 - 2 rear, fender mounted
 - 2 rear, cab mounted
 - 1 rear, for ripper point
- Seat, air suspension, fabric, heated, low back, rotates 12.5° to right, headrest
- Seat belt, 76 mm **3"**, retractable
- Seat belt indicator
- Sealed electrical connectors
- Starting motor, 11.0 kW/24V
- Steering system:
 - Hydrostatic Steering System (HSS)
- Torque converter with auto lock-up
- Track roller guards, end sections
- Track shoe assembly
 - Sealed and lubricated
 - 610 mm **24"** extreme service shoes
- Transmission with auto/manual shift modes
- Underguards, heavy duty
 - Hinged belly pans
- Variable Geometry Turbocharger (VGT)
- Water separator, fuel
- Wide core cooling package, 6 fins per inch spacing

* Dozer assembly and rear mounted equipment are not included in base machine standard equipment

** Cab meets OSHA/MSHA ROPS and FOPS Level 2 standards



OPTIONAL EQUIPMENT

Shoes

Shoes, single grouser	Additional weight	Ground contact area	Shoes, single grouser	Additional weight	Ground contact area
660 mm 26" extreme service	+240 kg +530 lb	43230 cm ² 6,700 in²	660 mm 26" PLUS extreme service	+819 kg +1,806 lb	43230 cm ² 6,700 in²
710 mm 28" moderate service	No additional	46505 cm ² 7,208 in²	710 mm 28" PLUS extreme service	+1029 kg +2,269 lb	46505 cm ² 7,208 in²
610 mm 24" PLUS extreme service	+569 kg +1,254 lb	39955 cm ² 6,193 in²			

Variable multi-shank ripper

- Additional weight (including hydraulic control unit): 3760 kg **8,290 lb**
- Beam length: 2320 mm **7'7"**
- Hydraulically-controlled parallelogram-type ripper with three shanks. Digging angle infinitely adjustable. Standard digging angle*: 49°
- Maximum digging depth: 900 mm **2'11"**
- Maximum lift above ground: 950 mm **3'1"**

Variable giant ripper

- Additional weight (including hydraulic control unit): 2440 kg **5,380 lb**
- Beam length: 1400 mm **4'7"**
- Hydraulically-controlled parallelogram-type ripper with one shank. Digging angle infinitely adjustable. Standard digging angle*: 49°
- Maximum digging depth: 1240 mm **4'1"**
- Maximum lift above ground: 950 mm **3'1"**

* Measured with ripper point on ground and shank vertical.

Other

- HD Counterweight 9-plate with rigid drawbar, 3568 kg **7,860 lb**

Dozer Equipment

- SIGMADOZER®
- Semi-U

AESS888-0326-V4

©2026 Komatsu America Corp.

Printed in USA

AD10(3M)OSP

KOMATSU®

Note: All comparisons and claims of improved performance made herein are made with respect to the prior Komatsu model unless otherwise specifically stated.

www.komatsuamerica.com

Komatsu America Corp. is an authorized licensee of Komatsu Ltd. Materials and specifications are subject to change without notice

KOMATSU, Komatsu Care®, KOMTRAX® and KOMTRAX Plus® are registered trademarks of Komatsu Ltd. All other trademarks and service marks used herein are the property of Komatsu Ltd., Komatsu America Corp. or their respective owners or licensees.